



IMPORTANT



Be Sure
to Read this
Manual
Before Use

UNS[®]
UNIVERSAL SPACE

www.universal-space.com

Operation Manual

WE ARE HERE TO ASSIST For parts and service



Have Questions? Contact us!

UNIS SERVICE CENTER

Tel: 972-241-4263

Email: service@unispartsandservice.com

When contacting Service, you will need the following information
and the name of your authorized distributor.

INDOOR MACHINE	
NAME: Zombie Night(GMP)	MAX POWER: 500W
MODEL: C-558	MIN POWER: 270W
S/N:	FREQUENCY: 50/60Hz
VOLTAGE: AC110V~	DATE:
GUANGDONG UNIS TECHNOLOGY CO., LTD	

INDOOR MACHINE	
NAME: Zombie Night(GMP)	MAX POWER: 500W
MODEL: C-558	MIN POWER: 270W
S/N:	FREQUENCY: 50/60Hz
VOLTAGE: AC220-240V~	DATE:
GUANGDONG UNIS TECHNOLOGY CO., LTD	

CONTENT

IMPORTANT SAFETY INSTRUCTIONS.....	3
1. SPECIFICATIONS.....	5
2.CONTENTS OF THE ACCESSORY KIT.....	7
3. PART NAME.....	8
4. SET UP & INSTALLATION.....	9
5. HOW TO PLAY.....	16
6. GAME OPTION.....	17
7. TROUBLESHOOTING.....	21
8. MAINTENANCE & INSPECTION.....	24
9. OVERALL CONSTRUCTION.....	31
10. WIRING DIAGRAM.....	56

Thank you for purchasing **Zombie Night**. We hope you enjoy the product.

This manual contains valuable information about how to operate and maintain your game machine properly and safely. It is intended for the owner and/or personnel in charge of product operation. Carefully read and understand the instructions.

If you need any help during installation and setup please utilize this manual and troubleshooting guide. If the product fails to function properly, *non-technical personnel should under no circumstance attempt to service the machine*. Contact your distributor or manufacturer for help.

Before use, please read **IMPORTANT SAFETY INSTRUCTIONS**.

IMPORTANT SAFETY INSTRUCTIONS

To ensure the safe usage of this product, carefully read and understand these instructions before operating your game.

Save these instructions for future reference.

Use this product only as described in this manual. Other uses not recommended may cause fire, electric shock or personal injury. Unplug the game from the outlet when not in use, when moving from one location to another, and before cleaning/servicing.

Explanations which require special attention are indicated by signs of warning. Depending on the potential hazardous degree, the terms: **NOTE**, **NOTICE**, and **WARNING** are used.

NOTE: A NOTE indicates useful hints or information about product usage.

NOTICE: A NOTICE indicates potential damage to product and how to avoid the problem.

WARNING: A WARNING indicates a potential for product damage or serious personal injury.

It is important to understand the meaning of the following HAZARD SIGNS before continuing:

High Voltage and Shock Hazard:

High voltage can cause electric shock.
Turn off/unplug power before servicing.



High Temperature Hazard:

This part may cause scalding.
Do not touch. Surface may be hot.



No Touching Hazard:

This part may be hot or can cause electric shock.
Do not touch.



Use the following safety guidelines to help ensure your own personal safety and to help protect your equipment and surrounding environment from potential damage.

⚠️ This product is an indoor game machine. Do not install outdoors.

Avoid installing in the following places to prevent fire, electric shock, injury and/or machine malfunctioning:

- Places subject to rain/moisture, or places subject to high humidity.
- Places subject to direct sunlight, or places subject to extremely hot or cold temperatures to ensure that it is used within the specified operating range.
- Places where inflammable gas may be present or in the vicinity of highly inflammable/volatile chemicals or items that can easily catch fire.
- On unstable or sloped surfaces. The machine may topple or cause unforeseen accidents.
- Vicinity of fire exits, fire extinguishers etc that may block/prevent safety measures.

IMPORTANT NOTE:

ALL REPAIRS MUST BE DONE TO ORIGINAL MANUFACTURER SPECIFICATIONS. FAILURE TO DO SO VOID ALL WARRANTIES AND OPERATOR ASSUMES ALL RISKS.

Note: The contents of this manual may be updated without notice.

1. SPECIFICATIONS

Rated power supply: AC110V~ 50/60 Hz; AC220-240V~ 50/60 Hz

Min. Power consumption: 270W

Max. Power consumption: 500W

Dimension: W41.34×D105.12×H82.68 in

W1050×D2670×H2100 mm

Weight: Approximately 694.5 lb/315kg

Part No: Z116

Model No: C-558



NOTICE: After turning off the game, please wait at least 1 minute before restarting again.

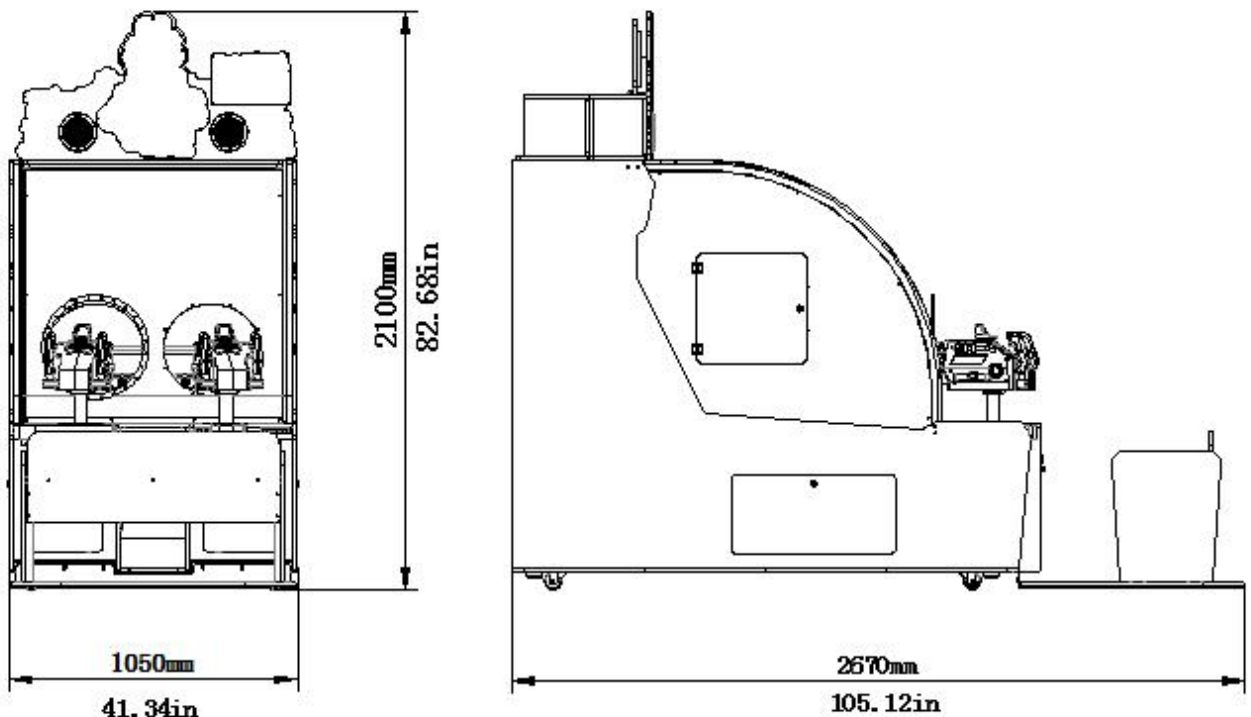

Note: Game specifications are subject to change without notice.

This machine will be divided into two parts during transportation.

Cabinet part: W41.34×D75.79×H82.68 in

W1050×D1925×H2100 mm

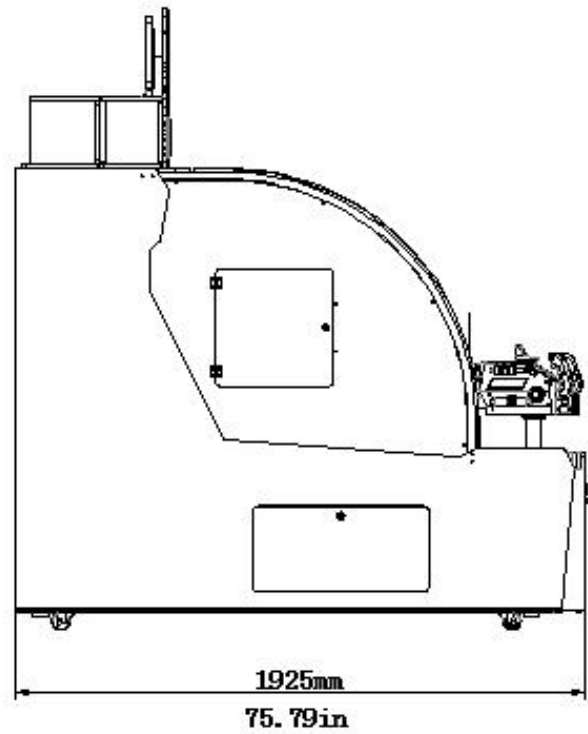
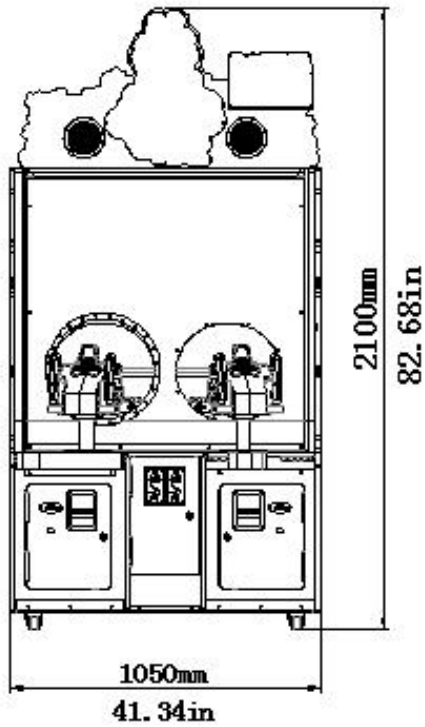

Seat part: W41.34×D32.52×H22.28 in

W1050×D826×H566 mm

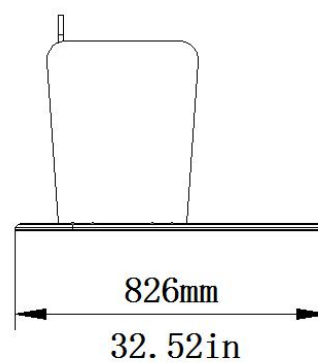
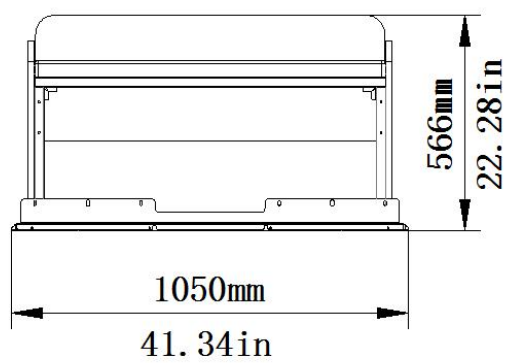

Note: Game specifications are subject to change without notice.

2.CONTENTS OF THE ACCESSORY KIT

Open the package and make sure all the items are included:

No.	Part No.	Code	Name	SPEC	Qty	Picture
1	Z116-802-000	25300171002	Key	171	2	
2	Z116-803-000	25300172002	Key	171B	2	
3	Z116-421-000	21901000013	Fuse	Φ5×20 T10A/250V	1	
4	Z116-463-000	23301000001	Power cord	10A/250V- 1.8M	1	
5	Z116-801-000	41440000287	Manual	/	1	/
6	Z116-362-000	20101008016	Hexagon socket button screw	M5×45	4	

NOTE: Part models are subject to change without notice.

3. PART NAME

Key Components



4. SET UP & INSTALLATION

! NOTICE

We do not recommend using power tools as they may cause damage.

- Refer to IMPORTANT SAFETY INSTRUCTIONS (Pg. 3) for places to avoid.
- Place the unit on a dry level surface.
- Ventilation openings in the back of the unit must not be obstructed by objects or by wall.

4.1 Transporting the Game

If you need to move the game, adjust the levelers back to an “up” position.

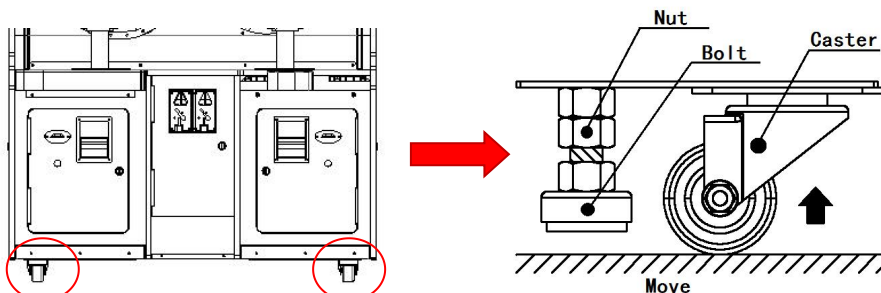

! NOTICE

- Be careful not to damage the machine during transport.
- Always unplug the game before moving.
- Keep the machine in upright position during transport.
- For longer distance transport, package the game properly to prevent damages.

4.2 Level Adjustment

Install this game on a flat surface. If the game is installed on an unsuitable floor, it could cause game malfunction.

To secure the game, loosen the nut, utilize wrench to adjust the leveler down until it touches the floor, lifting the casters off the ground by 0.2 in/5mm. Repeat the same for all levelers.

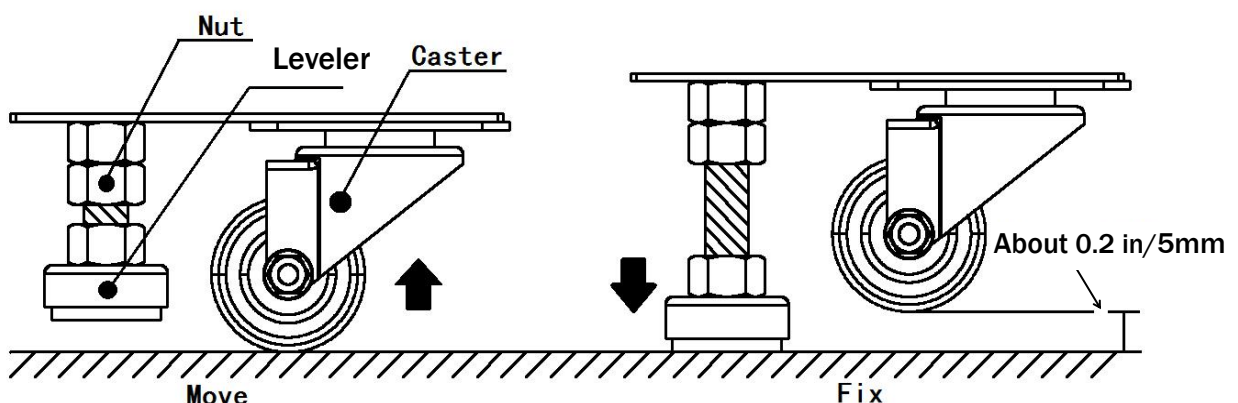

! NOTICE

Make sure the machine is level.

4.3 Play Zone

This machine requires space for playing and for maintenance as shown below. Leave space around the game upon installation:

Service area: 20 in

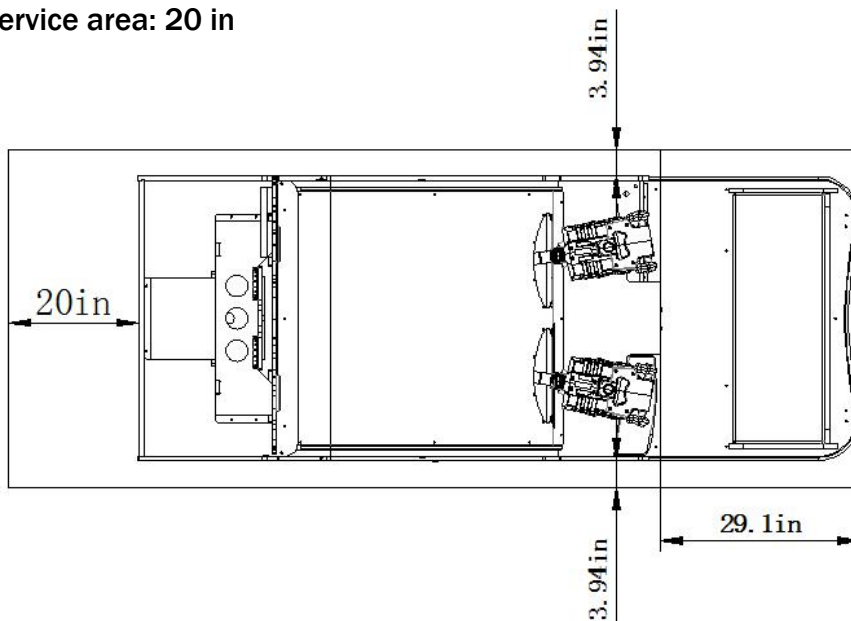

4.4 Voltage Conversion (110V convert to 220V)

Step 1 Power off the machine.

Step 2 Locate the power supplies inside the back box.

Step 3 Toggle the switches from 115V to 230V on the power supplies.

Step 4 Power on the machine.

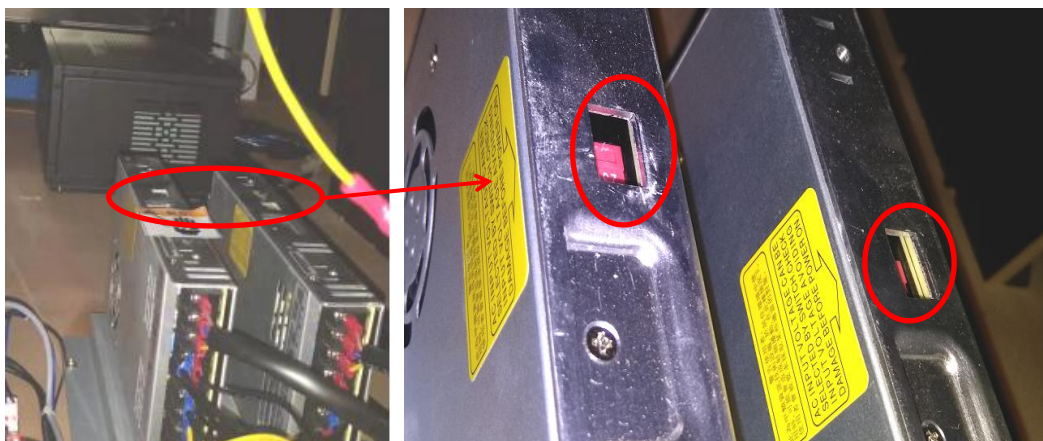



4.5 Card Reader Installation Safety Notice



Take precaution to assure that all wiring voltages are confirmed prior to installation of card reader. All warranties are void if not properly installed resulting in logic board damage.

4.6 Machine Installation

Before processing with assembly assure you have the following tools.

No.	Name	Picture
1	Phillips screwdriver	
2	Allen wrench	

4.6.1 Seat Assembly Installation

Step 1 Utilize Phillips screwdriver to tighten 4 screws to fix 2 Seat side plates to the base plate.

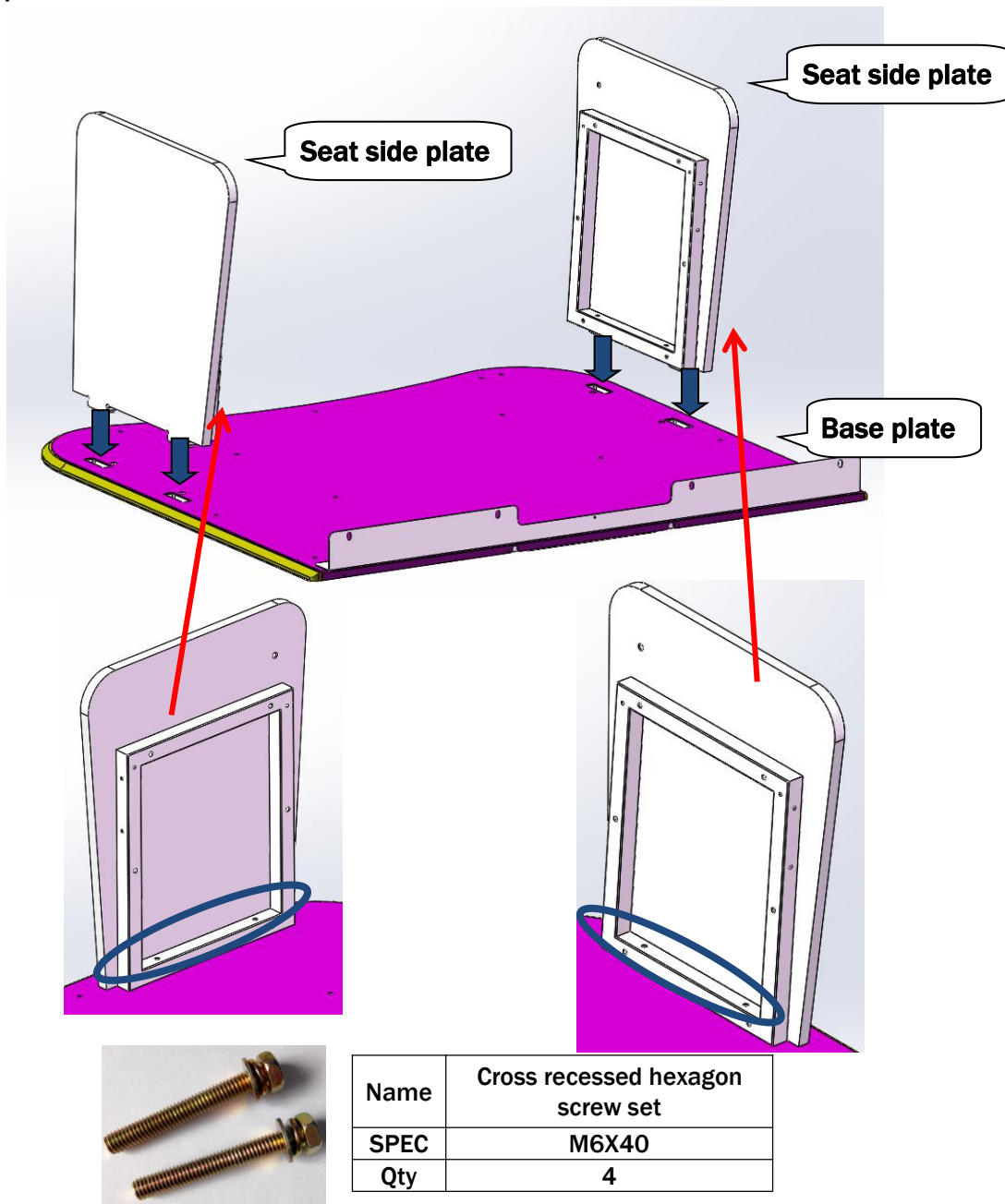

Step 2 Utilize Phillips screwdriver to tighten 4 screws to fix the Seat frame to 2 Seat side plates.

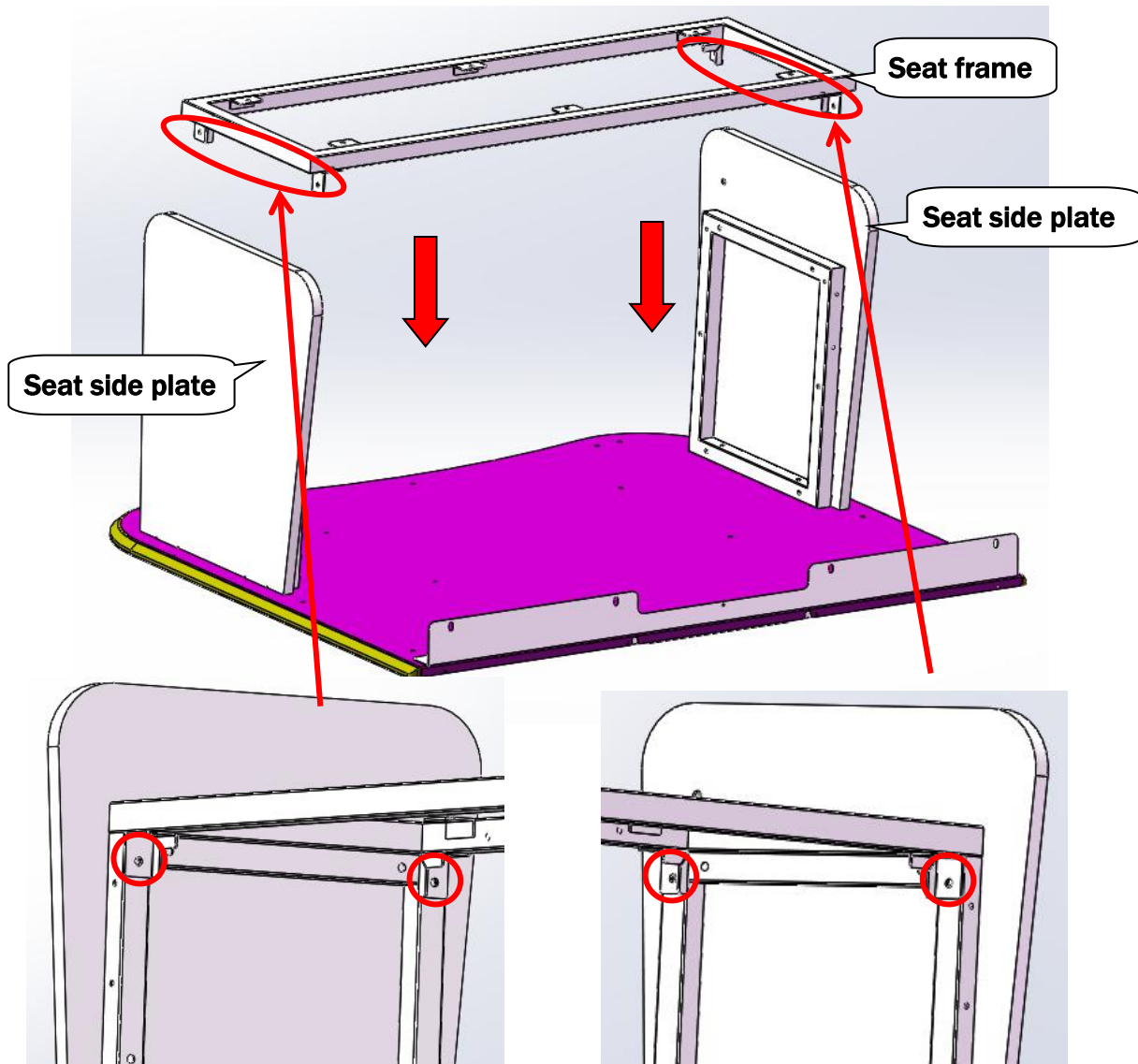

Name	Cross recessed hexagon screw set
SPEC	M6X12
Qty	4

Step 3 Utilize Allen wrench to tighten 7 screws to fix the Seat back plate to 2 Seat side plates.

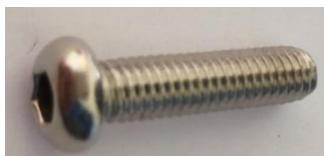
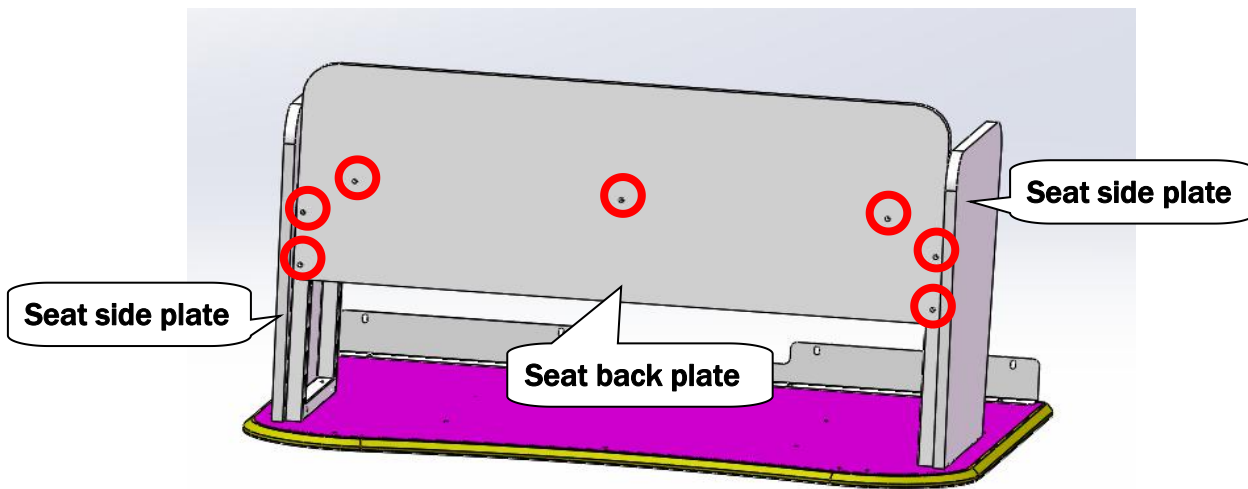

Name	Hexagon flat round head screw
SPEC	M6X25
Qty	7

Step 4 Utilize Phillips screwdriver to tighten 4 screws to fix the Seat back plate and 2 Seat side plates together.

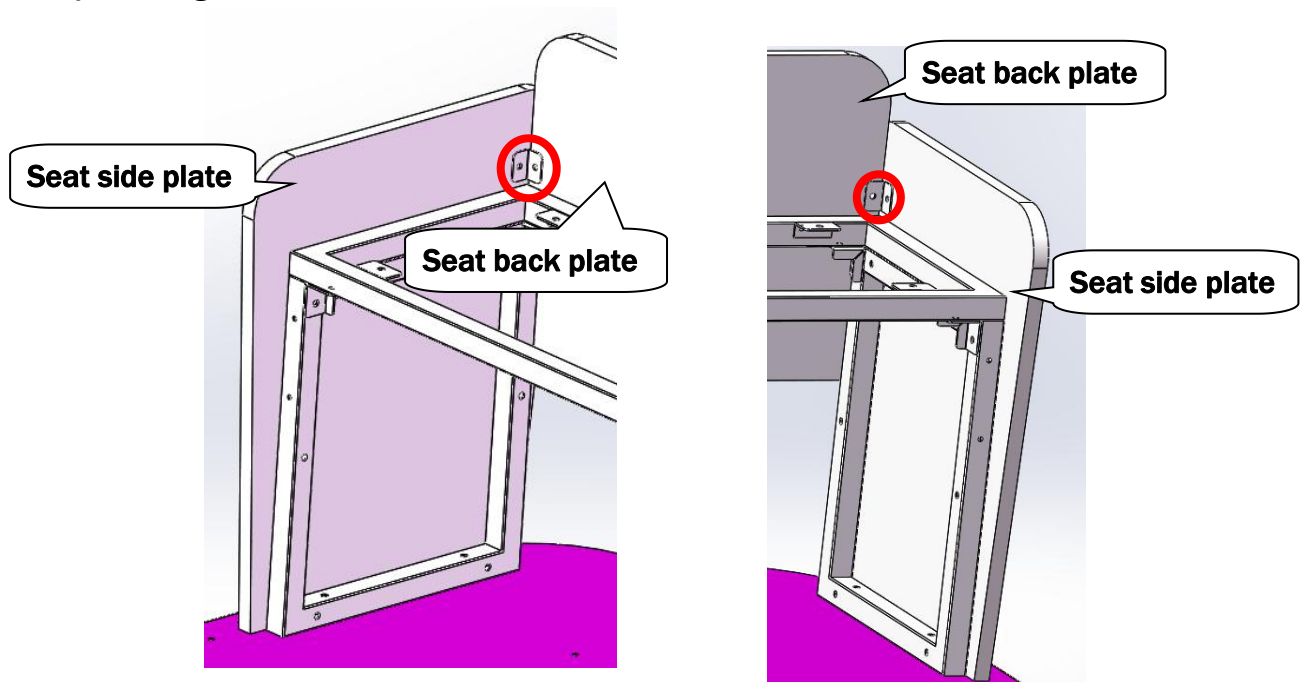

Name	Cross recessed pan head screw set
SPEC	M4X12
Qty	4

Step 5 Utilize Allen wrench to tighten 6 screws to fix the Seat plate to the Seat frame.

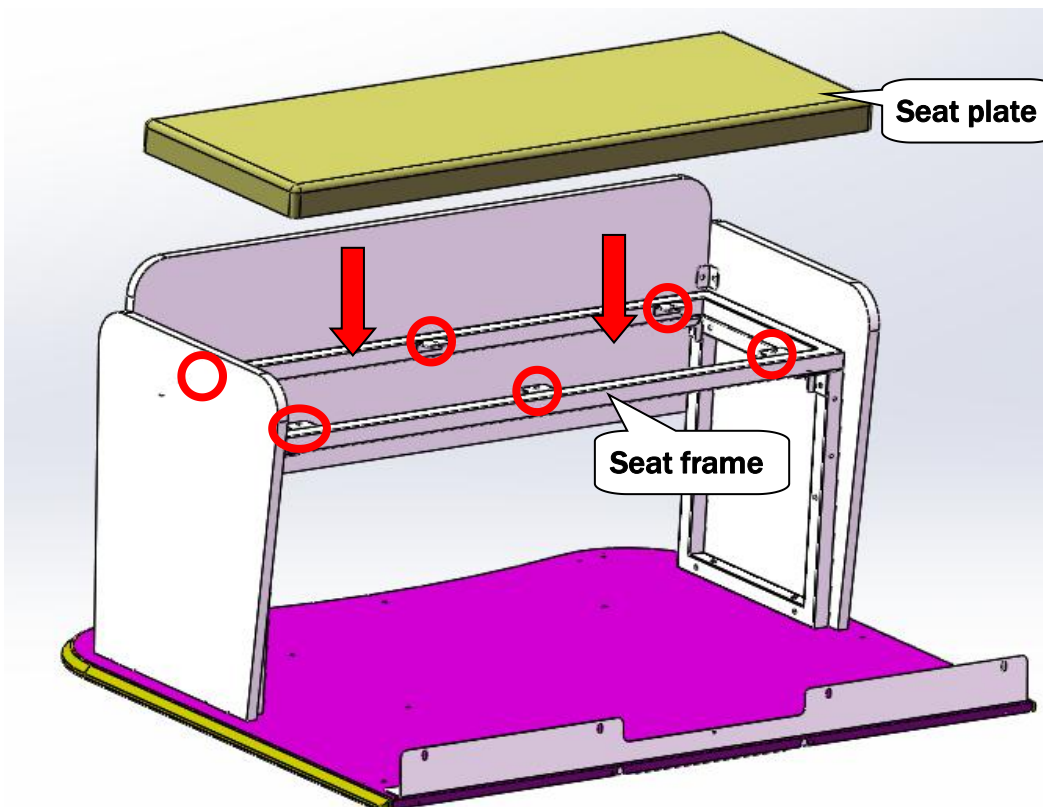

Name	Hexagon flat round head screw
SPEC	M6X16
Qty	6

4.6.2 Combination Instruction

Step 1 Route the cable from the Seat assembly through the hole indicated into the Main cabinet and connect.

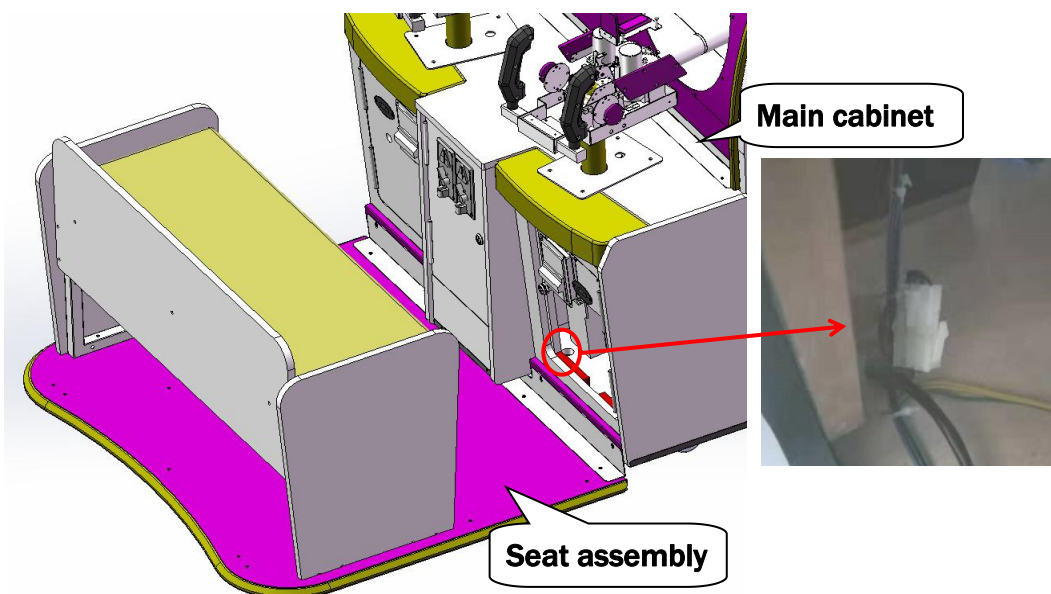

Step 2 Utilize Allen wrench to tighten 4 screws to fix the Seat assembly to the Main cabinet.

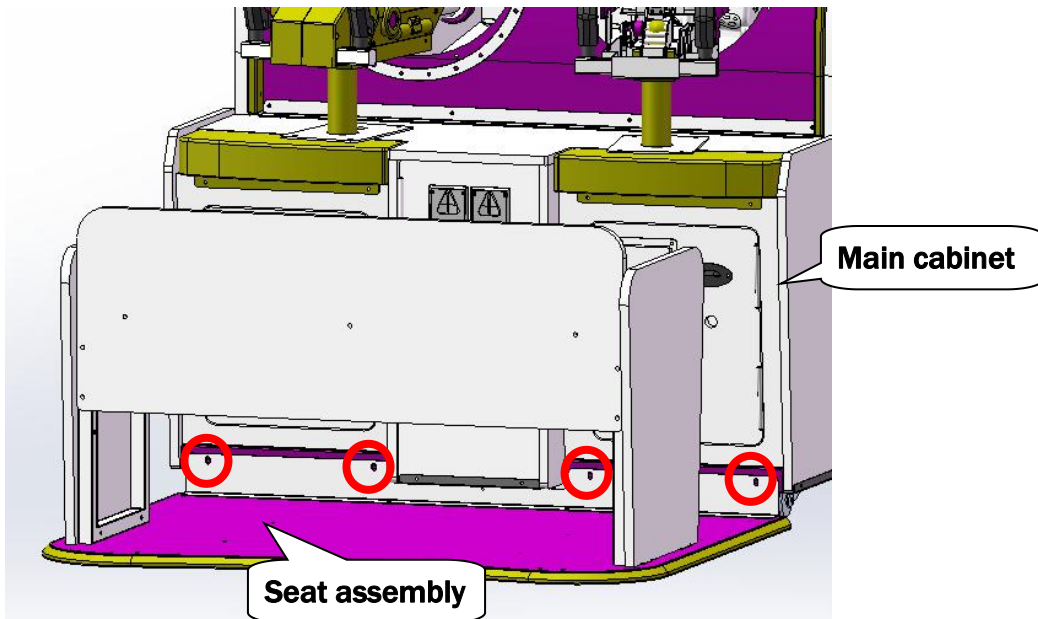

Name	Hexagon flat round head screw
SPEC	M5X45
Qty	4

Finish!

5. HOW TO PLAY

1. Insert coins, choose character and stage to play.



2. Pull triggers to shoot the zombies, coins, other items on the screen and zombie toys.



3. Press Energy buttons (the upper two buttons) to activate Flame Attack.



4. Get high score to unlock the following stages.

6. GAME OPTION

6.1 Adjustment button instruction

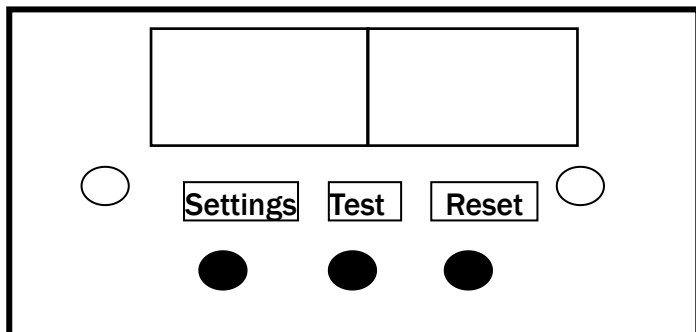

Open the coin door and there is a meter panel. Press Settings button to enter the setting menu.

6.2.1 Main Menu

Basic Setting
Input Test
Output Test
Game Reset
Date/Time Setting
Customized Setting
About This Game
Language/语言
Bookkeeping
DailyRecord
Gun Calibration
Back to game

6.2.2 Basic Setting

Free Play	YES_NO
Tickets Out	YES_NO
Demo music	YES_NO
Memory Save	YES_NO
Volume	0-10
Coins Per Game	1-200
Out of Tickets	YES_NO
Back&Save	
Back	

6.2.3 Input Test

1P Coin
2P Coin
1P Shoot Key
2P Shoot Key
1P Energy Key
2P Energy Key
1 Track Sensor Front
2 Track Sensor Front
3 Track Sensor Front
4 Track Sensor Front
1 Track Sensor Back
2 Track Sensor Back

3 Track Sensor Back
4 Track Sensor Back
1 Toy Sensor
2 Toy Sensor
3 Toy Sensor
4 Toy Sensor
1P Send Ball
2P Send Ball
1P X
1P Y
2P X
2P Y
Back

6.2.4 Output Test

1P TicketDriver
2P TicketDriver
1 Toy Lamp
2 Toy Lamp
3 Toy Lamp
4 Toy Lamp
1 Toy Lamp G
2 Toy Lamp G
3 Toy Lamp G
4 Toy Lamp G

1 Toy Lamp R
2 Toy Lamp R
3 Toy Lamp R
4 Toy Lamp R
Side Lamp R
Side Lamp G
Side Lamp B
1P Gun Lamp R
1P Gun Lamp G
1P Gun Lamp B

2P Gun Lamp R
2P Gun Lamp G
2P Gun Lamp B
Doll Lighting W
1 Track Motor
2 Track Motor
3 Track Motor
4 Track Motor
Back

6.2.5 Game Reset

Factory restore	YES_NO
Reset Basic Setting	YES_NO
Reset Customized Setting	YES_NO
Clear all records	YES_NO
Clear owed ticket	YES_NO
Clear unused coin	YES_NO
Back	

6.2.6 Date/Time Setting

Year	2010-2100
Month	1-12
Day	1-31
Hour(24)	0-23

Minute	0-59
Second	0-59
Back&Save	
Back	

6.2.7 Customized Setting

Fixed Ticket	YES_NO
Bonus Score	5000-15000
Bonus	10-9999
Level A Ticket	0-10
Level B Ticket	0-10

Level C Ticket	0-10
Level D Ticket	0-10
Back & Save	
Back	

6.2.8 About This Game

CPU
MainBoard
HDD
RAM
Monitor
Screen
Version
Press the Test Button to Go Back

6.2.9 Bookkeeping

Player
Coins
Payout Tickets
NON RESETTABLE POINTS
NON RESETTABLE TICKETS
Back

6.2.10 DailyRecord

Date
Weekday
RunTime
Coins
Pay out Tickets
Pay out
Clear
Back

6.2.11 Gun Calibration

Aim at the spot with 1P gun. Press shooting button to confirm.
Aim at the spot with 2P gun. Press shooting button to confirm.
Press the Test Button to Go Back

6.3 SW Settings:

Item	Content	SW1							
		1	2	3	4	5	6	7	8
Version	中文版/Aeon Ver.	OFF							
	GMP Ver.	on							
			off	off	off	off	off	off	off
SW2									
Item	Content	1	2	3	4	5	6	7	8
		off	off	off	off	off	off	off	off
SW3									
Item	Content	1	2	3	4	5	6	7	8
					OFF				
U6 board update	No				OFF				
	Yes				on				
		off	off	off		off	off	off	off

7. TROUBLESHOOTING





7.1 Common Problem

Please confirm that all connectors fit tightly.

Symptom	Possible Cause	Recommended action
Game will not start	Frame assembly connector is loose.	Check connector.
	Frame assembly fault	Contact with UNIS Service.
Power off	Circuit protector make power SW in off state.	Turn on power SW again. If appeared again and again, machine has anomaly. Please contact with UNIS Service.
No sound	Low volume	Raise the volume.
	Connector loose.	Check connector.
	Speaker fault.	Check speaker.
	POT installation error.	Install POT correctly.
	POT fault.	Change POT.
	Audio cable problem.	Reconnect the audio cable or change it.
	PC crash.	Restart or system recovery.
Display black screen	Driver problem	Restart the audio driver.
	Check connectors.	Plug in connector tightly
	Display fault.	Utilize another source such as a PC to verify if the display is operational.
Display blue screen	RAM is loose.	Remove and reinsert RAM.
	PC power cord is loose	Check PC power cord whether is loose.
	VGA signal cable is loose.	Check VGA cable
	PC video card is loose.	Reseat video card.
	“0X000000A” code appears. Conflict between computer drive and software.	Contact service

Note: After replacing component from pc (except for RAM), and replacing monitor, the game should be recovered again with the recovery stick attached to the machine.

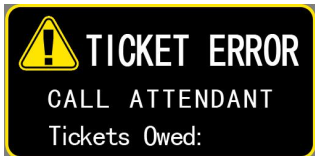
If you see following error signs showing on the display, please try the recommended action.

Display	Possible Cause	Recommended action
 	The connection part of the IO board and PC are loose.	Check and reconnect the loose ports of the PC or IO board.
	Cable quality problem	Change the cable after checking the connection between IO board and PC.
	Cable became loose during transportation.	Check and reconnect the loose cables of the PC or IO board.
	IO board is faulty.	Reboot the game after checking connection and cable problem, if the problem remains unresolved, please call the service department for assistance.
	Out of ticket.	Refill ticket
	Loose connection of the ticket dispenser's cables.	Check and reconnect the loose cables to the ticket dispenser.
	Ticket dispenser is faulty.	Change the ticket dispenser.
	Ticket jam.	Remove jammed tickets.
	Out of ticket.	Refill ticket

7.2 System Recovery Operation **(NOTE: Do not disconnect power during this process.)**

1. Turn off the game. Remove recovery stick from the machine. (Note: This process may take up to 60 minutes) Insert the recovery stick into the port at the back of the computer.
2. Restart PC to enter the system recovery screen as shown.

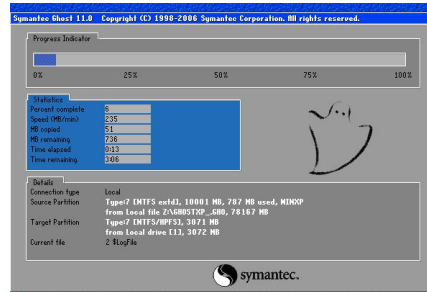

3. The game will automatically start recovery.
4. Once system recovery is partially finished (as shown below), and the ICON appears, remove the recovery stick from the computer. The game will continue the install process.

OK to remove the recovery stick.



5. Assure that the recovery stick has been properly secured for future use.



WARNING: The recovery stick should only be used to fix software errors. Using it for other purposes may cause unexpected results and damages.

8. MAINTENANCE & INSPECTION

8.1 Safety Check

Check the points listed before operating the machine. These checks are necessary for safe machine operation:

1. Test game before operation each day.
2. Conduct monthly routine checks of game components to ensure good working condition.
3. Check the machine regularly for dust and clean when necessary.

Note: Parts and components require preventative maintenance to maintain proper operation.

8.2 Handling Precautions

When installing or inspecting the machine, be very careful and pay attention to ensure that the player can enjoy the game safely.

Inappropriate handling running counter to the cautionary matters can cause personal injury or damage to the machine.

 **NOTICE**

We do not recommend using power tools as they may cause damage.

8.3 Belt Adjustment Instruction

Before processing, assure you have the following tool.

No.	Name	Picture
1	Phillips screwdriver	

Step 1 Open the Bottom back door. Locate the Motor fixed plate and utilize Phillips screwdriver to loosen 4 screws (don't remove).

Step 2 Pull the Motor as the big arrow's direction to make the belt tight. Utilize Phillips screwdriver to tighten 4 screws back.

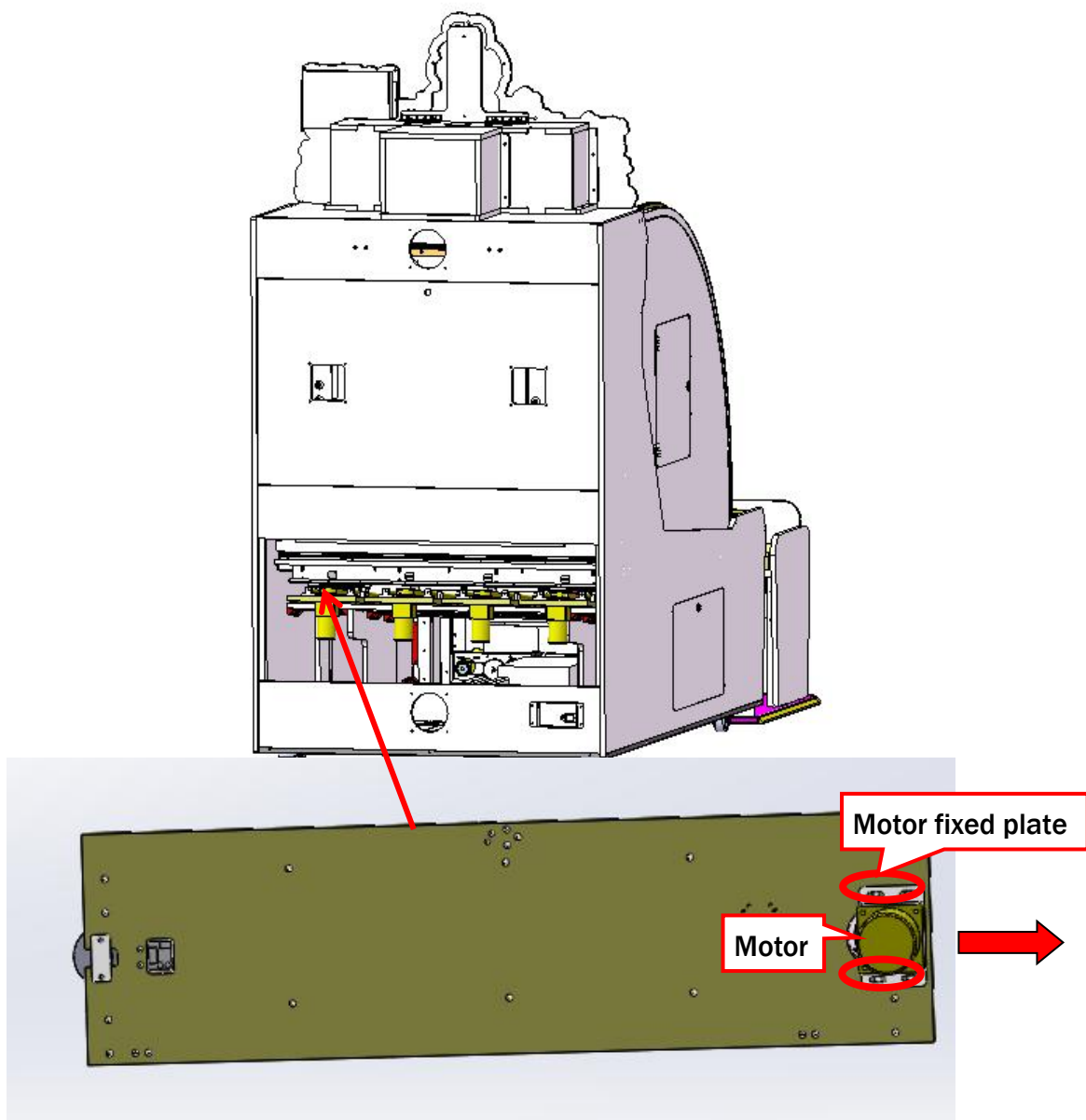

8.4 Belt Replacement Instruction

Before processing, assure you have the following tool.

No.	Name	Picture
1	Phillips screwdriver	

Step 1 Utilize Phillips screwdriver to loosen 8 screws indicated to remove the Carpet.

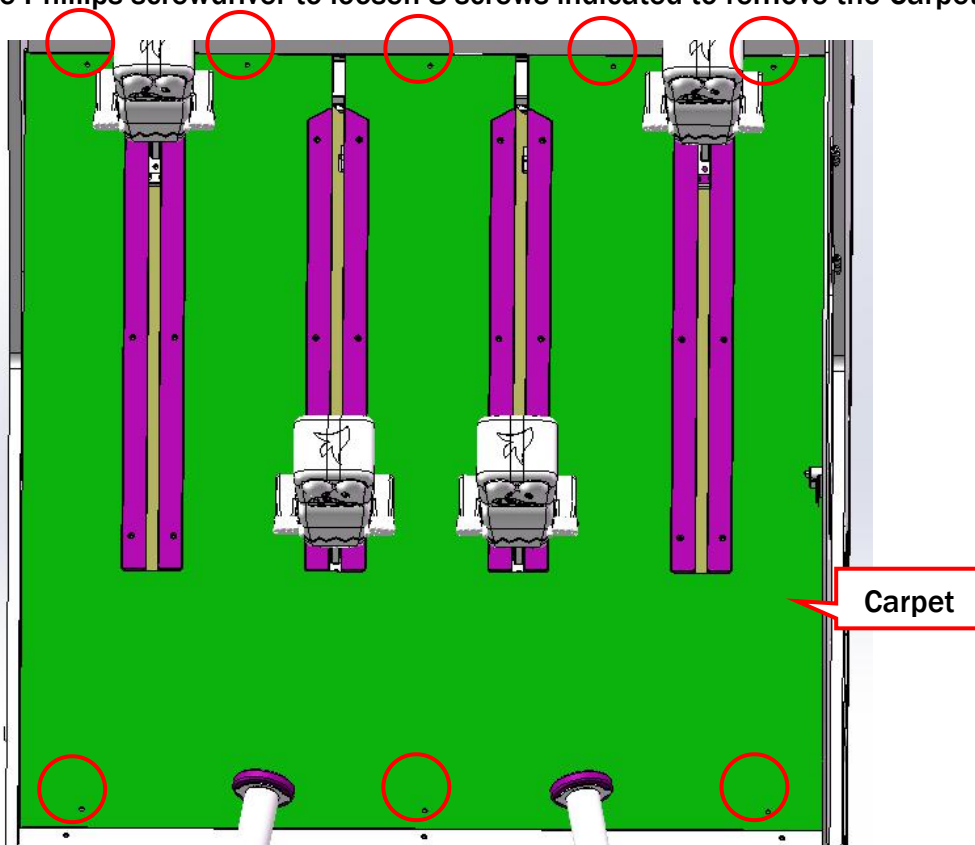

Step 2 Utilize Phillips screwdriver to loosen screws on the Track cover plates to remove the corresponding Track cover plates.

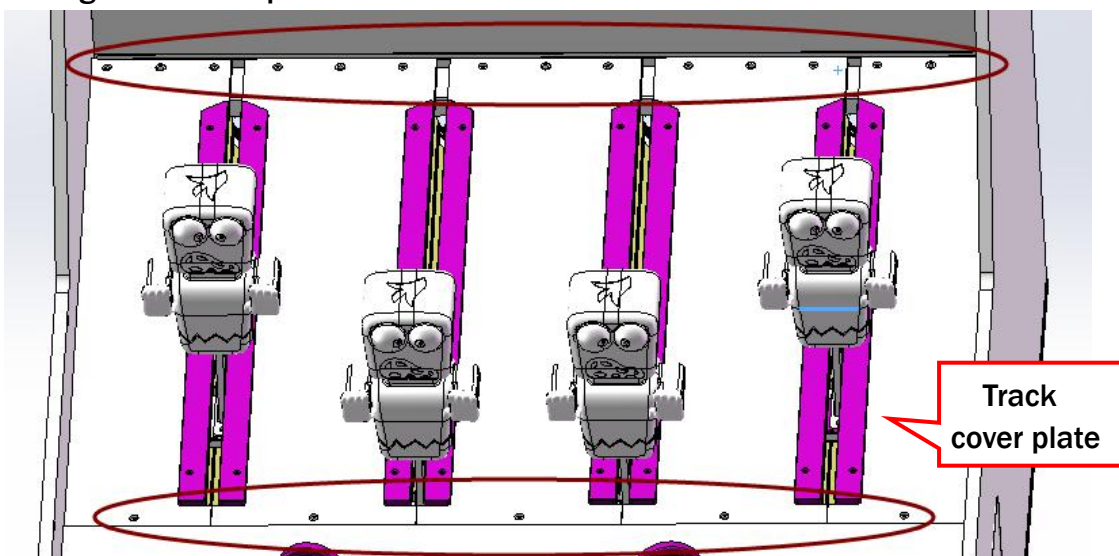

Step 3 Utilize Phillips screwdriver to loosen 6 screws on the Track plate.

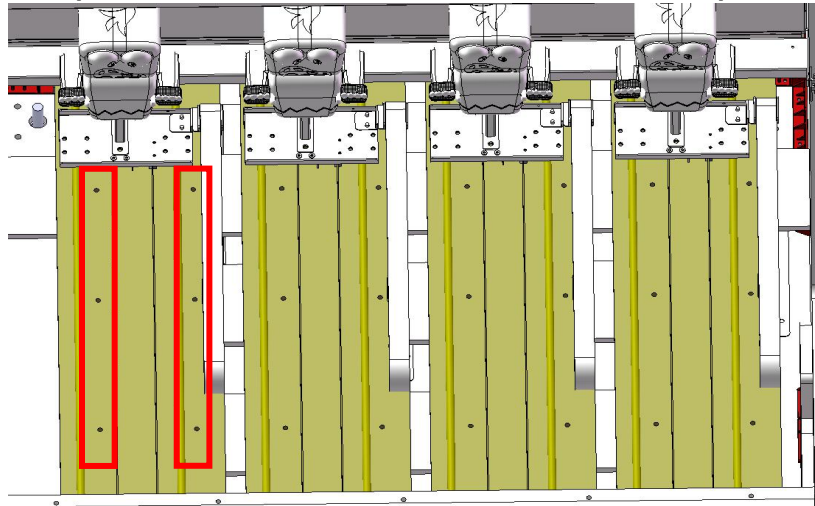

Step 4 Locate the Motor by opening the Bottom back door. Utilize Phillips screwdriver to loosen 4 screws on Motor fixed plate indicated.

Move the Motor as the arrow's direction to loosen the belt.

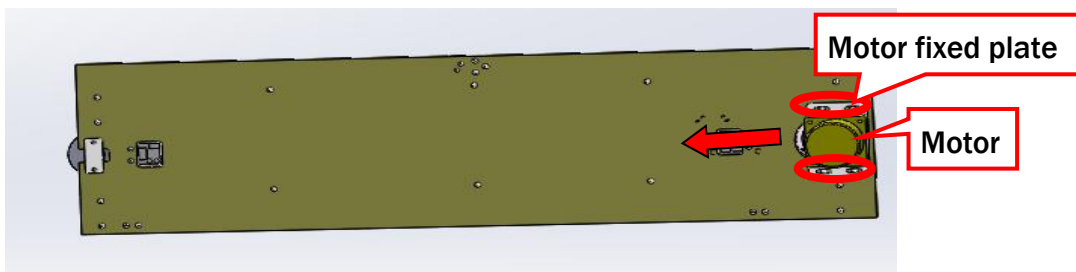

Step 5 Utilize Phillips screwdriver to loosen 2 screws indicated by circle to remove the belt.

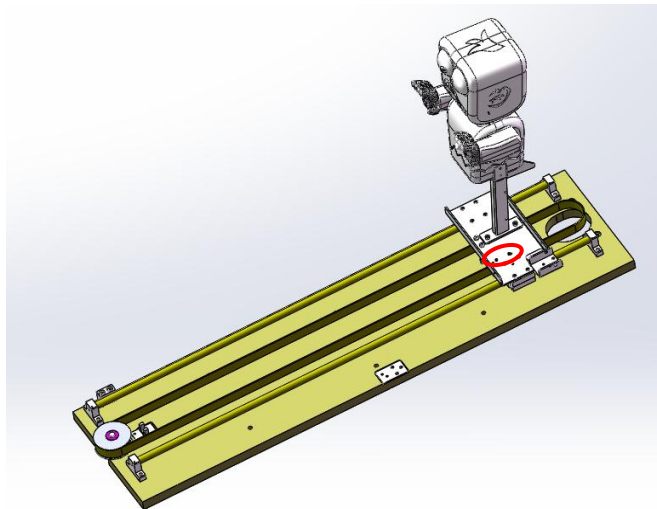

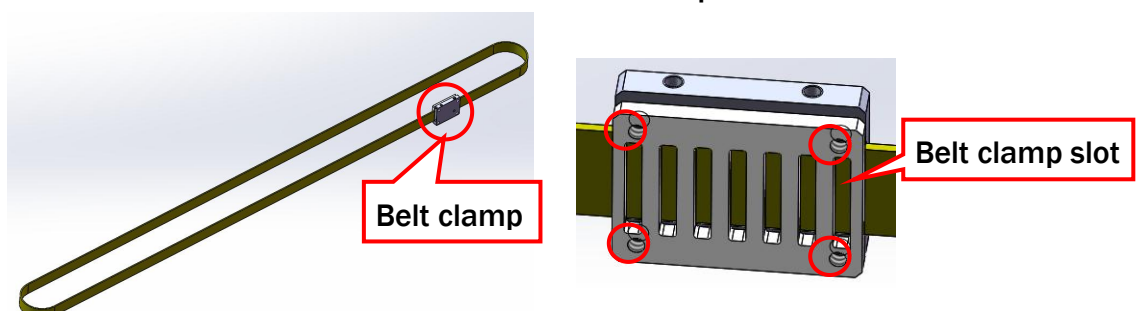

Step 6 Utilize Phillips screwdriver to loosen 4 screws indicated by circles to remove the Belt clamp. Replace a new belt and install in reverse order.

Note: The belt teeth should match the slots of Belt clamp.



8.5 Motor Replacement Instruction

Before processing, assure you have the following tools.

No.	Name	Picture
1	Phillips screwdriver	
2	Allen wrench	

Step 1 Open the Bottom back door. Locate the Motor fixed plate and utilize Phillips screwdriver to remove 4 screws.

Step 2 Pull the Motor as the big arrow's direction to loosen the belt. Remove the Motor.

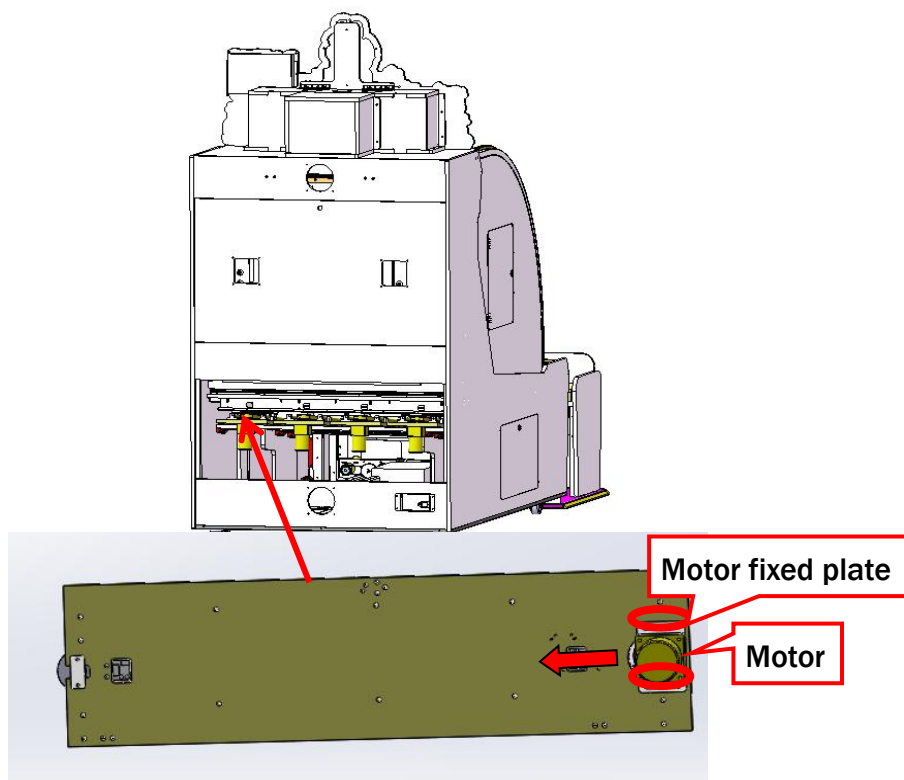

Step 3 Utilize Allen wrench to loosen 2 screws indicated by rectangles to remove Synchronizing wheel.

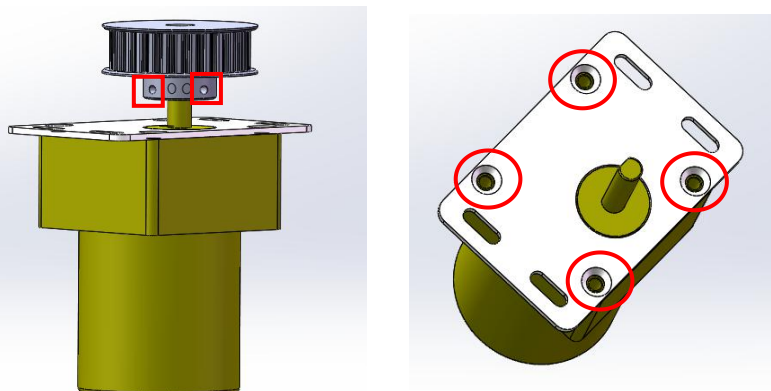

Utilize Phillips screwdriver to loosen 4 screws indicated by circles to remove the plate.



Step 4 Replace with a new motor and install in reverse order. (Make sure the belt is installed tight.)

8.6 Shooting Force Adjustment Instruction

Before processing, assure you have the following tools.

No.	Name	Picture
1	Spanner (No.7)	
2	Allen wrench(No.3)	

Step 1 Remove the gun shell, utilize Spanner to loosen 2 Hexagon nuts.

Step 2 Utilize Allen wrench to twist the Hexagon socket cup head screws counterclockwise to make the Roll ball wheels move to center direction as the big arrows' direction, and that will reinforce the shooting force.

Oppositely, utilize Allen wrench to twist the Hexagon socket cup head screws clockwise, that will weaken the shooting force.

Step 3 Install in reverse order.

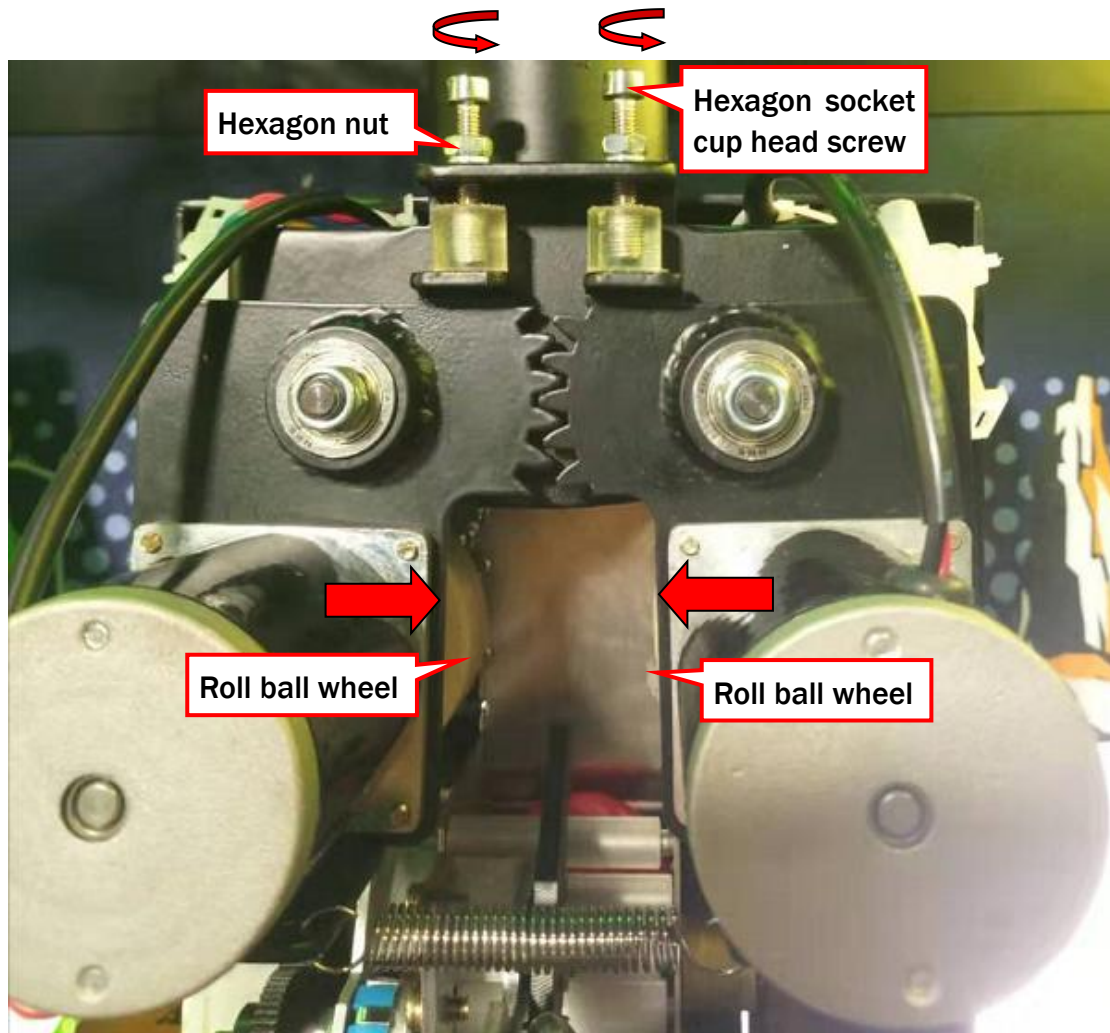

8.7 Send Ball Tube Inspection Instruction

Before processing with assembly assure you have the following tool.

No.	Name	Picture
1	Phillips screwdriver	

Utilize Phillips screwdriver to remove 4 screws to remove the tube to check if there is jam. Clear the jam and install back.

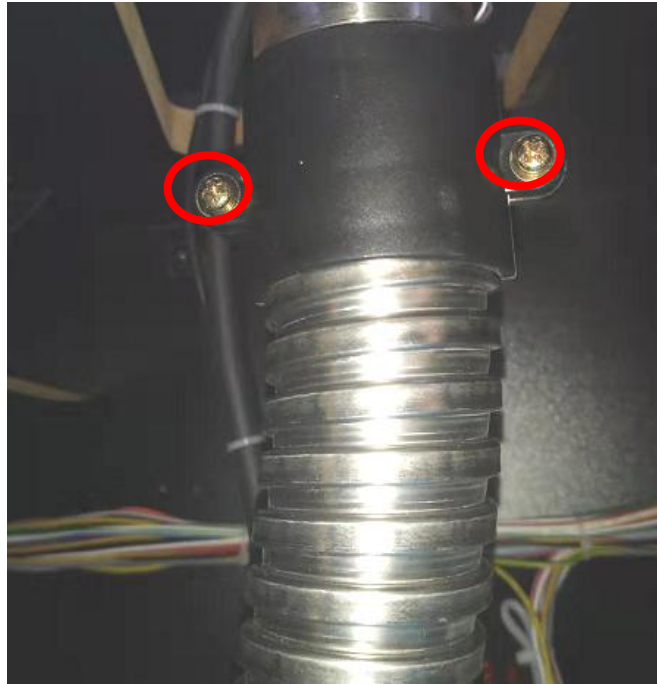

9. OVERALL CONSTRUCTION

9.1 Wooden Frame Assembly

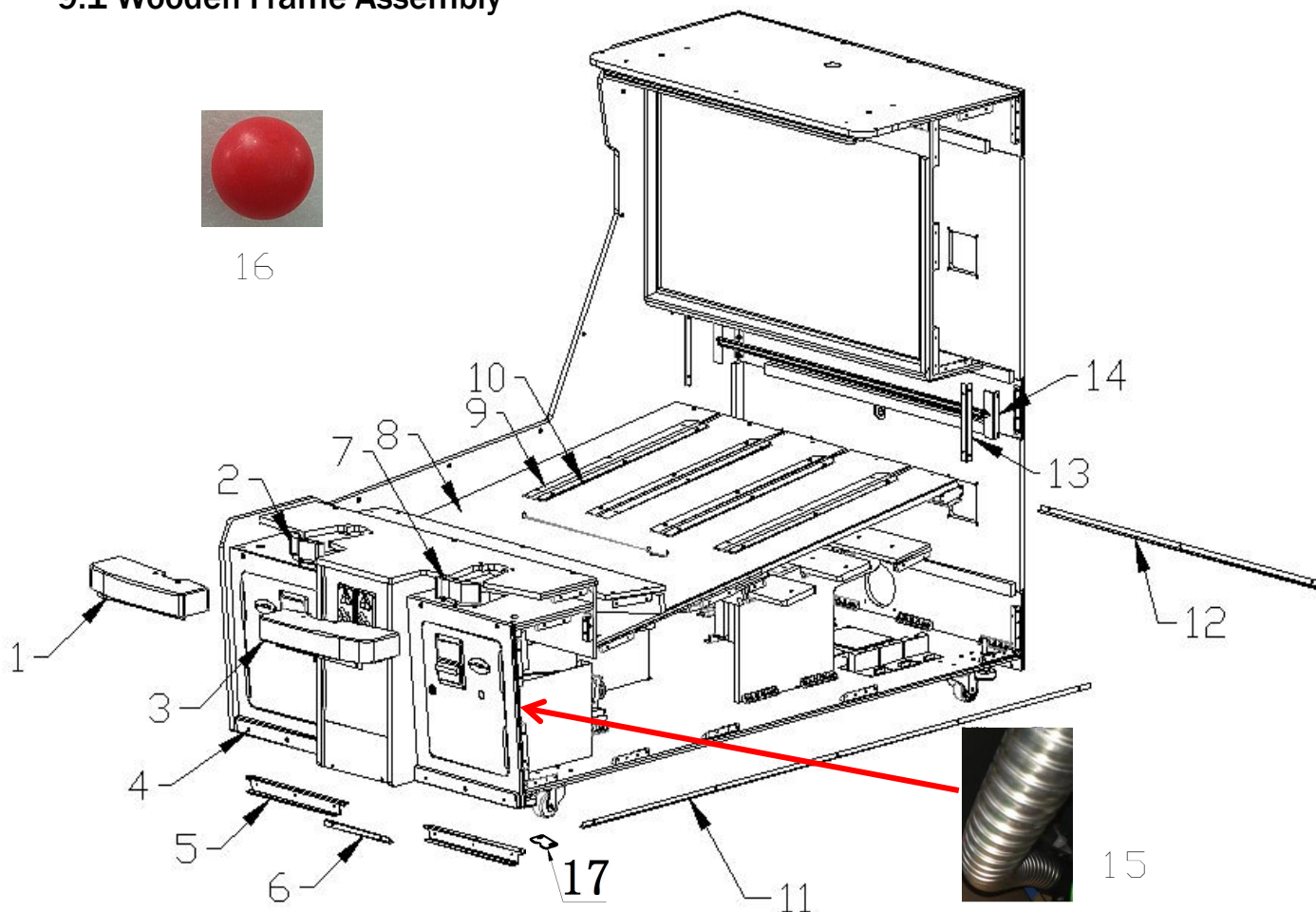

No.	Part No.	Code No.	Name	Qty
1	Z116-173-000	20641833001	Control panel L light cover	1
2	Z116-105-000	20241833003	L gun fixed bracket	1
3	Z116-174-000	20641833002	Control panel R light cover	1
4	Z116-224-000	20641833004	Front bottom light plastic	2
5	Z116-113-001	20241833062A	Front bottom plate	2
6	Z116-109-000	20241833007	Front middle moulding	1
7	Z116-106-000	20241833004	R gun fixed bracket	1
8	Z116-172-000	20641833029A	Carpet	1
9	Z116-226-000	20641833006	Track L light plastic	4
10	Z116-225-000	20641833005	Track R light plastic	4
11	Z116-104-000	20241833002	Side moulding	2

No.	Part No.	Code No.	Name	Qty
12	Z116-103-000	20241833001	Back moulding	1
13	Z116-108-000	20241833006	Background plate fixed plate	2
14	Z116-107-000	20241833005	Background light fixed plate	2
15	Z116-455-000	25106023105	Pipe	2
16	Z116-176-000	20641833033	Ball	200
17	Z116-252-000	20241833093	Bottom wiring plate	2

9.2 Gun Assembly

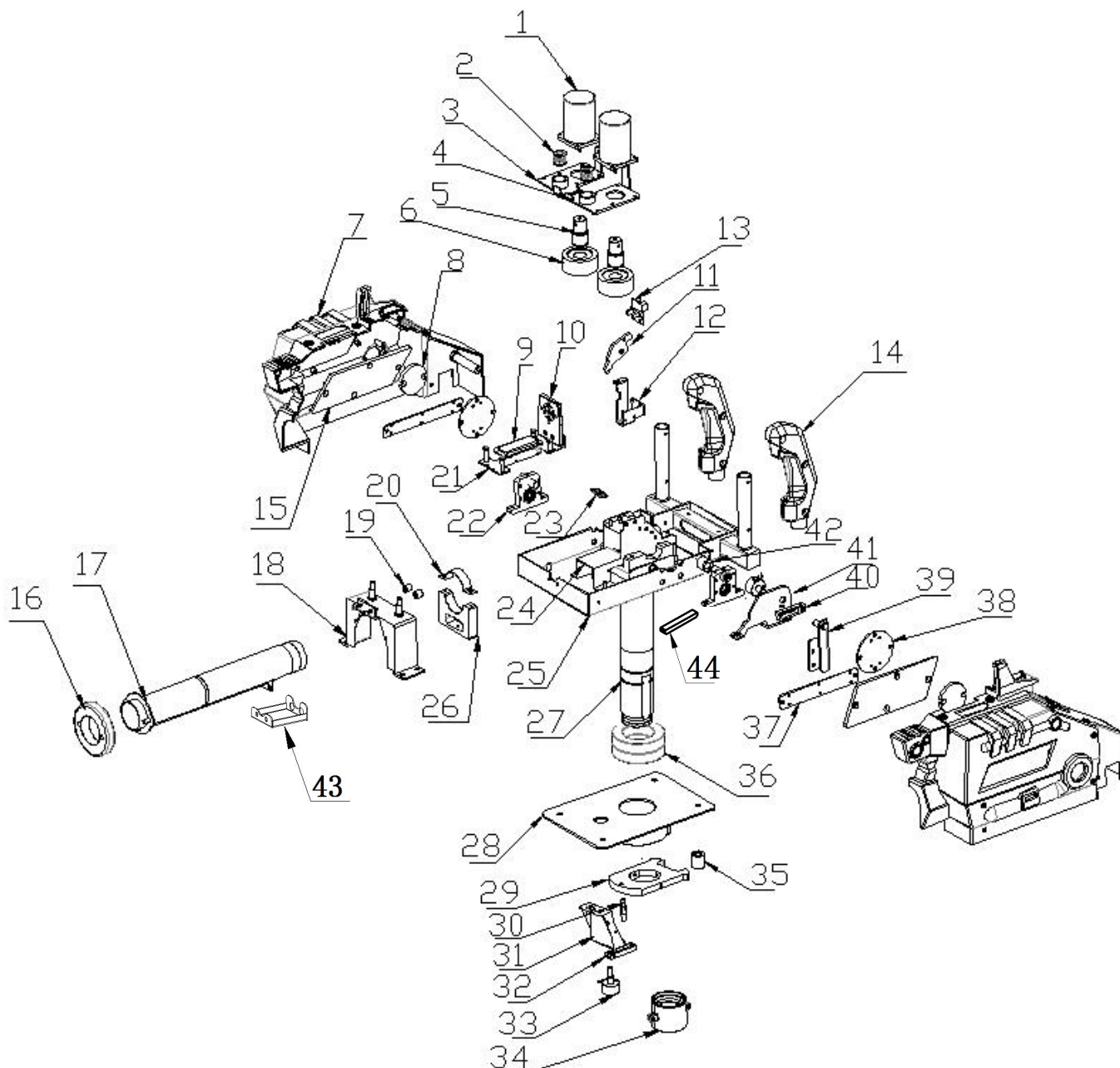

No.	Part No.	Code No.	Name	Qty
1	Z116-476-000	23404000256	Motor	2x2
2	Z116-468-000	20106000012	Deep grove ball bearing	4x2
3	Z116-122-000	20241833017A	Gun motor R fixed plate	1x2
4	Z116-121-001	20241833016A	Gun motor L fixed plate	1x2
5	Z116-185-000	20241833077	Wheel hub	2x2
6	Z116-220-001	20641833043	Wheel	2x2
7	Z116-189-000	20641833038	Gun cover	1x2
8	Z116-231-000	20641833010	Gun side round plastic	2x2
9	Z116-229-000	20641833009	Gun top plastic	1x2
10	Z116-230-000	20641833016	Gun sight plastic	1x2
11	Z116-191-000	20641833022	Block ball POM	1x2
12	Z116-124-000	20241833063	Sensor bracket	1x2
13	Z116-414-000	29710704001	Sensor board	1x2
14	Z116-475-000	20841123001	Handle	2x2
15	Z116-228-000	20641833008	Gun side plastic	2x2
16	Z116-227-000	20641833007	Gun head plastic	1x2
17	Z116-188-000	20241833019	Shoot ball tube	1x2
18	Z116-120-000	20241833015	Shoot ball motor bracket	1x2
19	Z116-186-000	20641833036	PU pad	2x2
20	Z116-123-000	20241833018	Shoot ball tube pressing plate	1x2
21	Z116-125-000	20241833064	Gun top light fixing plate	1x2
22	Z116-181-000	20241833071	Bearing holder	2x2
23	Z116-190-000	20241833068	Shoot ball spring	1x2
24	Z116-118-000	20241833055	Turning joint	1x2
25	Z116-117-002	20241833013B	Gun base plate	1x2
26	Z116-187-000	20241833078	Shoot ball tube fixing bracket	1x2

No.	Part No.	Code No.	Name	Qty
27	Z116-177-000	20241833011	Rotation shaft	1x2
28	Z116-115-000	20241833010	Gun base plate	1x2
29	Z116-247-000	20241906011	Bottom encoder limit plate	1x2
30	Z116-244-000	20241833088	X shaft fixing shaft	1x2
31	Z116-116-001	20241833012A	L&R POT fixing plate	1x2
32	Z116-246-000	20241833090	POT plate	1x2
33	Z116-453-000	22501000030	5K POT	1x2
34	Z116-200-000	20641833021	Shoot ball connective tube	1x2
35	Z116-180-000	20641833034	L&R PU sleeve	1x2
36	Z116-474-000	20106000332	Deep groove ball bearing	1x2
37	Z116-439-000	29741833003	Light board	2x2
38	Z116-437-000	29741833001	Light board	2x2
39	Z116-245-001	20241833089A	Y shaft fixing block	1x2
40	Z116-246-000	20241833090	POT plate	1x2
41	Z116-119-001	20241833014A	POT fixing plate	1x2
42	Z116-182-000	20641833035	PU sleeve	1x2
43	Z116-251-000	20241833094	Gun cover bottom plate	1x2
44	Z116-250-000	20641833044	Gun bottom foam	1x2

9.3 Left Send Ball Assembly

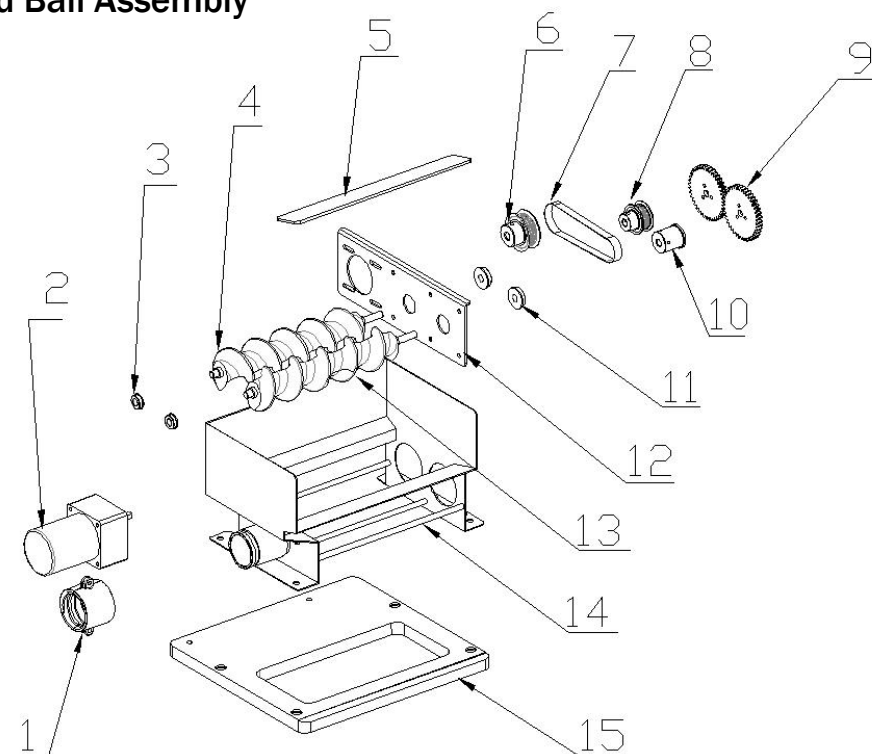

No.	Part No.	Code No.	Name	Qty
1	Z116-200-000	20641833021	Shoot ball connective tube	1
2	Z116-466-000	23404000255	DC motor	1
3	Z116-468-000	20106000012	Deep grove ball bearing	2
4	Z116-221-000	20641702002	R screw rod	1
5	Z116-199-000	20641833026	EVA foam	1
6	Z116-196-000	20241833079	Motor synchronizing wheel	1
7	Z116-467-000	26504000124	Toothed belt	1
8	Z116-197-000	20241833080	Rod synchronizing wheel	1
9	Z116-223-000	20641702004	Gear	2
10	Z116-198-000	20241833081	Gear fixing flange	1
11	Z116-469-000	20106000102	Deep grove ball bearing	2
12	Z116-130-000	20241833023	L motor fixing plate	1
13	Z116-222-000	20641702003	L screw rod	1
14	Z116-129-002	20241833056B	L ball collection bracket	1
15	Z116-539-000	20341833A036	L base plate	1

9.4 Right Send Ball Assembly

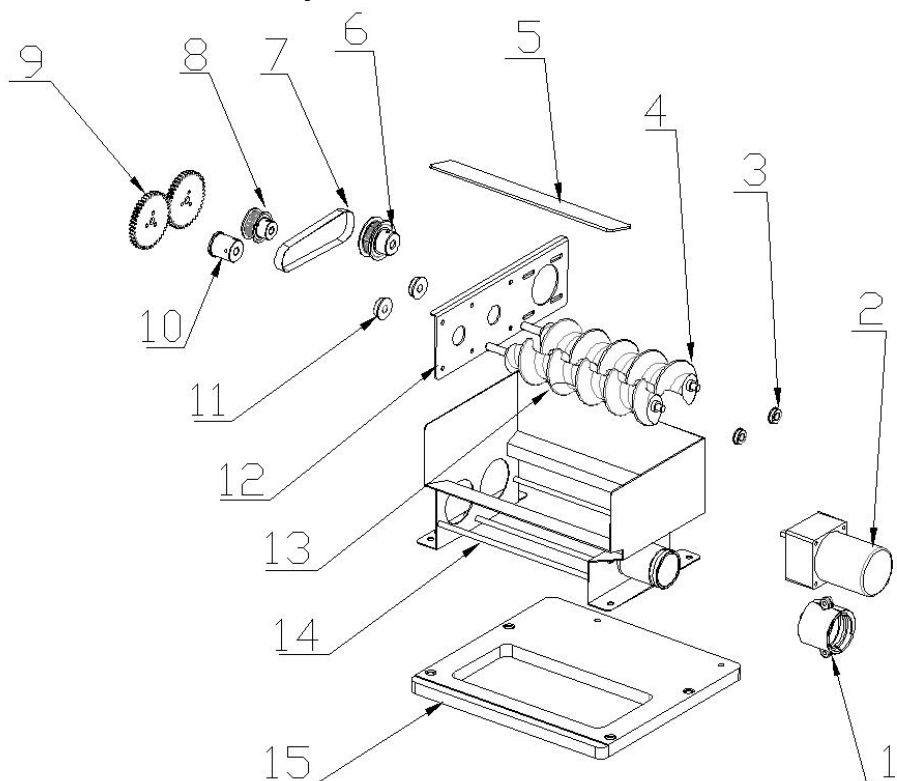

No.	Part No.	Code No.	Name	Qty
1	Z116-200-000	20641833021	Shoot ball connective tube	1
2	Z116-466-000	23404000255	DC motor	1
3	Z116-468-000	20106000012	Deep groove ball bearing	2
4	Z116-221-000	20641702002	R screw rod	1
5	Z116-199-000	20641833026	EVA foam	1
6	Z116-196-000	20241833079	Motor synchronizing wheel	1
7	Z116-467-000	26504000124	Toothed belt	1
8	Z116-197-000	20241833080	Rod synchronizing wheel	1
9	Z116-223-000	20641702004	Gear	2
10	Z116-198-000	20241833081	Gear fixing flange	1
11	Z116-469-000	20106000102	Deep groove ball bearing	2
12	Z116-132-000	20241833024	R motor fixing plate	1
13	Z116-222-000	20641702003	L screw rod	1
14	Z116-131-002	20241833057B	R ball collection bracket	1
15	Z116-540-000	20341833A037	R base plate	1

9.5 Track Assembly

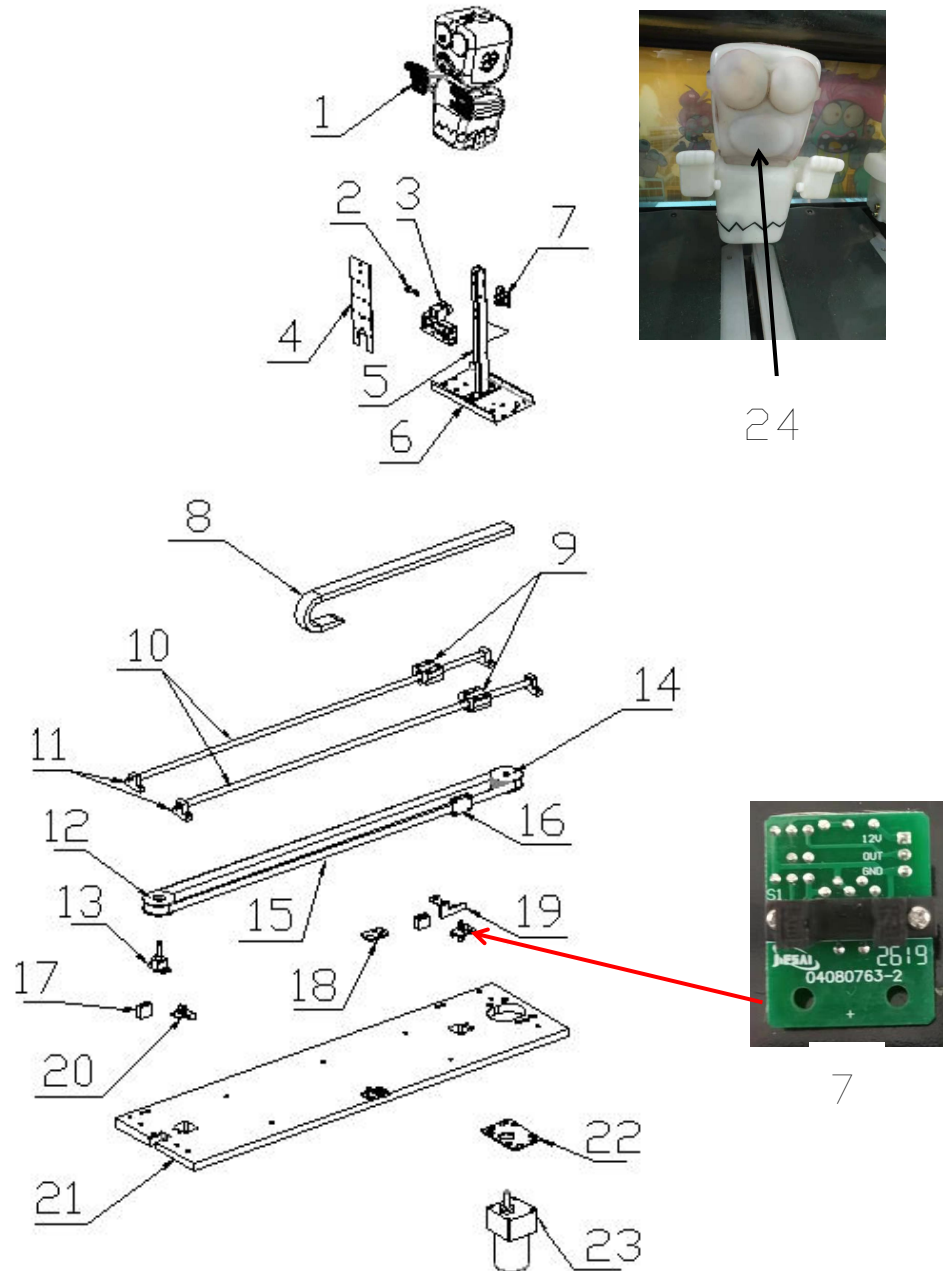

No.	Part No.	Code No.	Name	Qty
1	Z116-209-000	20641833003	Zombie toy	1x4
2	Z116-208-000	20241833073	Rotation shaft	1x4
3	Z116-139-001	20241833034A	Fixing bracket	1x4
4	Z116-436-000	29741833007	Light board	1x4
5	Z116-138-000	20241833033	Toy support	1x4

No.	Part No.	Code No.	Name	Qty
6	Z116-136-000	20241833031	Sliding block cover	1x4
7	Z116-414-000	29710704001	Sensor board	1x4
8	Z116-457-000	26503020028	Plastic chain	1x4
9	Z116-470-000	20106110286	Bearing pedestal	2x4
10	Z116-203-000	20241833076	Track	2x4
11	Z116-201-000	20241833025	Track bracket	4x4
12	Z116-206-000	20241833083	Driven wheel	1x4
13	Z116-202-000	20241833026	Belt bracket	1x4
14	Z116-205-000	20241833082A	Motor synchronizing wheel	1x4
15	Z116-471-000	26504010003	Toothed belt	62.6 in x4 (1.59m x4)
16	Z116-134-000	20241833029	Belt inner clamp	1x4
	Z116-207-000	20241833028	Belt outer clamp	1x4
17	Z116-204-000	20641833037	PU block	2x4
18	Z116-140-000	20241833085	Fixing plate	1x4
19	Z116-133-000	20241833027	Sensor detection plate	1x4
20	Z116-414-000	29710704001	Sensor board	1x4
21	Z116-541-000	20341833A038	Base plate	1x4
22	Z116-137-000	20241833032	Motor fixing plate	1x4
23	Z116-472-000	23404000257	Motor	1x4
24	Z116-248-000	20641833042	Zombie toy protective cover	1x4

9.6 Outer Cover Assembly

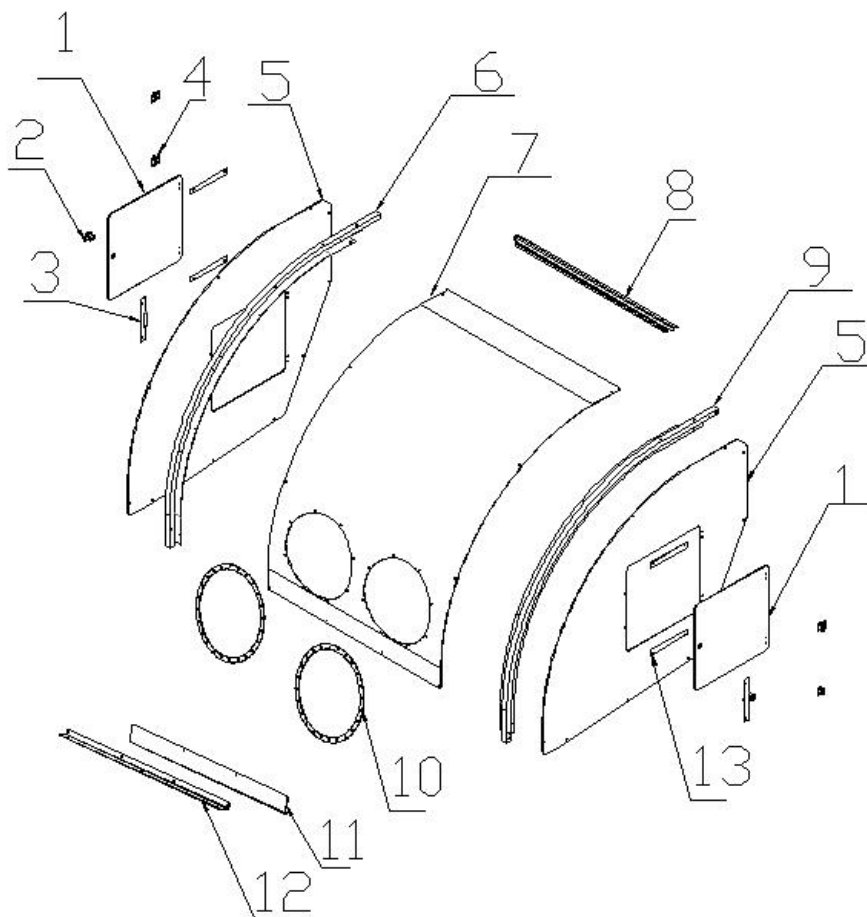

No.	Part No.	Code No.	Name	Qty
1	Z116-237-000	20641833018	Side plastic door	2
2	Z116-478-000	25300171001	171 Lock	2
3	Z116-153-000	20241833058	Side door plate	2
4	Z116-477-000	26300020034	Hinge	4
5	Z116-236-000	20641833017A	Side plastic	2
6	Z116-148-000	20241833042	L arc tube	1
7	Z116-235-000	20641833031	Front plastic	1
8	Z116-150-000	20241833044	Front plastic mounting plate	1
9	Z116-149-000	20241833043	R arc tube	1
10	Z116-211-000	20641833027	Net	2
11	Z116-152-000	20241833046	Front plastic plate	1
12	Z116-151-000	20241833045	Front plastic pressing plate	1
13	Z116-242-000	20241833087	Side door plate	4

9.7 Protective PVC Assembly

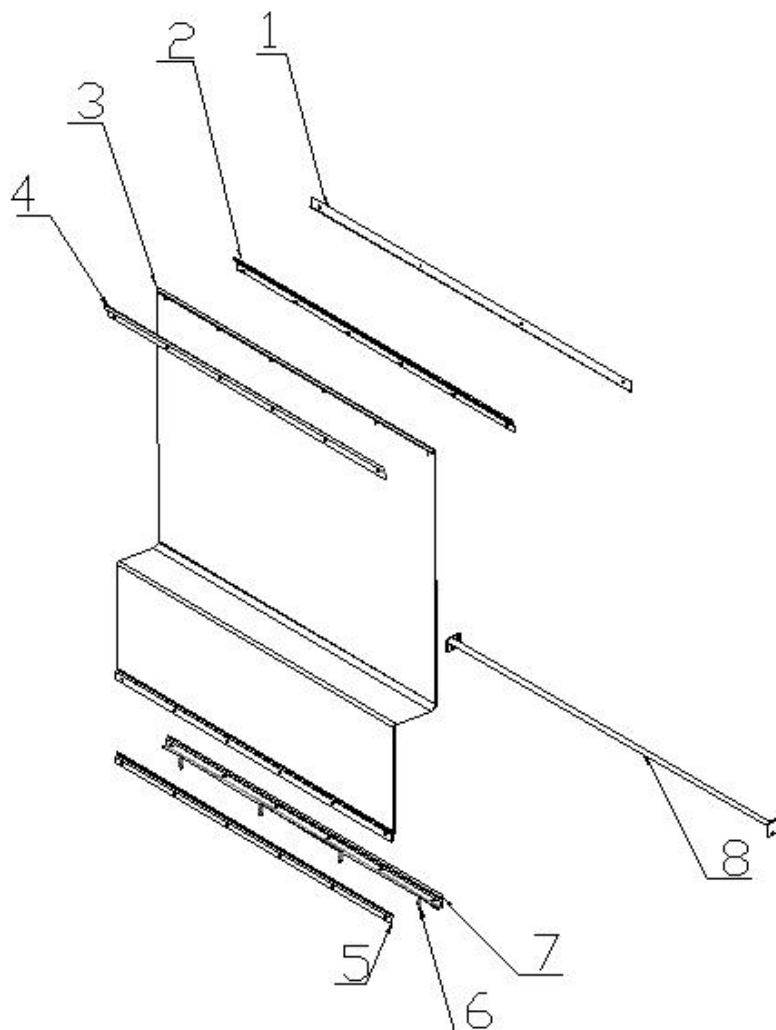

No.	Part No.	Code No.	Name	Qty
1	Z116-145-000	20241833039	Hook plate	1
2	Z116-142-000	20241833036	Hang plate	1
3	Z116-232-000	20641833030	Protective PVC	1
4	Z116-141-000	20241833035	Upper fixing plate	1
5	Z116-144-000	20241833038	Back inner fixing plate	1
6	Z116-210-000	20241833075	Spring	4
7	Z116-143-000	20241833037	Back outer fixing plate	1
8	Z116-146-000	20241833040	Rotation shaft	1

9.8 Marquee Assembly

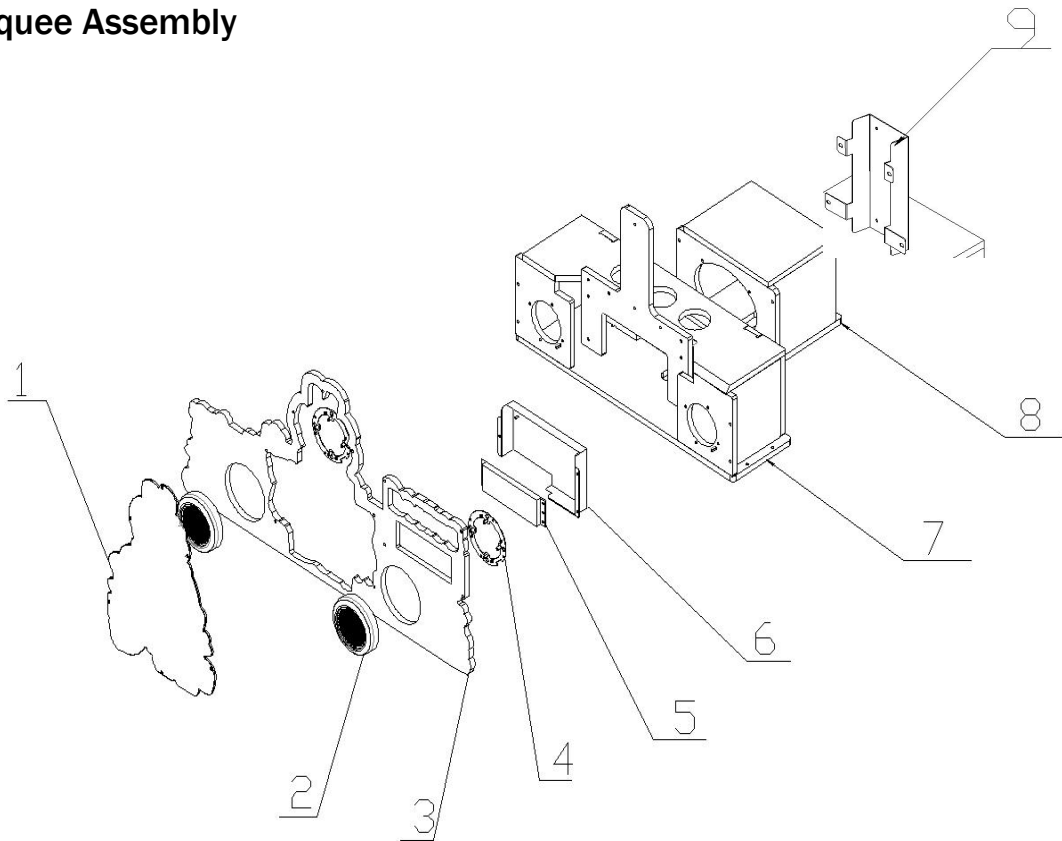

No.	Part No.	Code No.	Name	Qty
1	Z116-701-000	20541833A001	Marquee plastic	1
2	Z116-216-000	26000057003	Speaker light plastic	2
3	Z116-542-001	20341833A039A	Marquee base plate	1
4	Z116-170-000	26000057002	Speaker light plate	2
5	Z116-433-000	29741122003	Display	1
6	Z116-154-000	20241833047	Display holder	1
7	Z116-544-001	20341833A041A	Marquee case	1
8	Z116-543-000	20341833A040	Tweeter case	1
9	Z116-249-000	20241833092	Marquee back cover	1

9.9 Seat Assembly

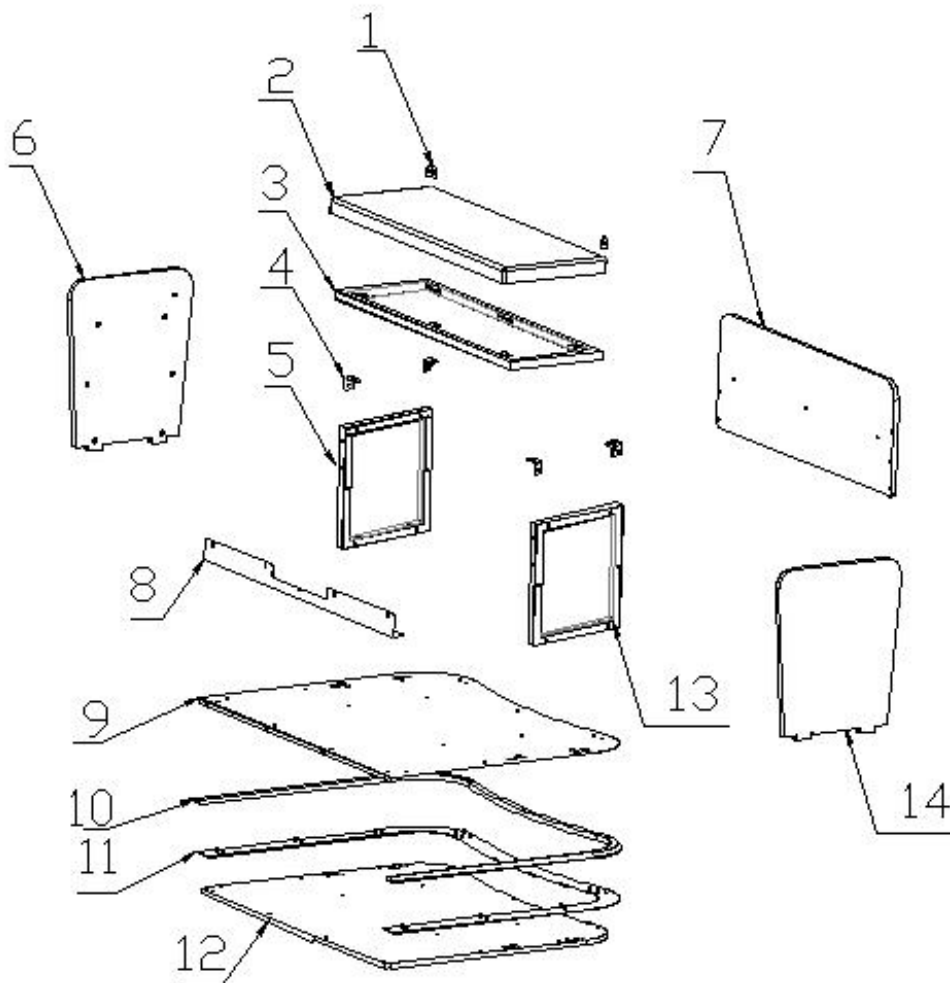

No.	Part No.	Code No.	Name	Qty
1	Z116-160-000	20241833051	Back connector	2
2	Z116-212-000	20641833020	Soft seat	1
3	Z116-159-000	20241833066	Beam	1
4	Z116-161-000	20241833052	Connector	4
5	Z116-158-000	20241833065	L frame	1
6	Z116-547-000	20341833044	L side plate	1
7	Z116-549-000	20341833046	Backrest	1
8	Z116-162-001	20241833053B	Connective plate	1
9	Z116-163-000	20241833084	Aluminium plate	1

No.	Part No.	Code No.	Name	Qty
10	Z116-239-000	20641833013	L light plastic	1
	Z116-240-000	20641833014	R light plastic	1
	Z116-241-000	20641833015	Back light plastic	1
11	Z116-155-000	20241833048	L connective plate	1
	Z116-156-000	20241833049	R connective plate	1
	Z116-157-000	20241833050	Back connective plate	1
12	Z116-545-000	20341833042	Base plate	1
13	Z116-164-000	20241833067	R frame	1
14	Z116-546-000	20341833043	R side plate	1

9.10 Wooden Frame Assembly

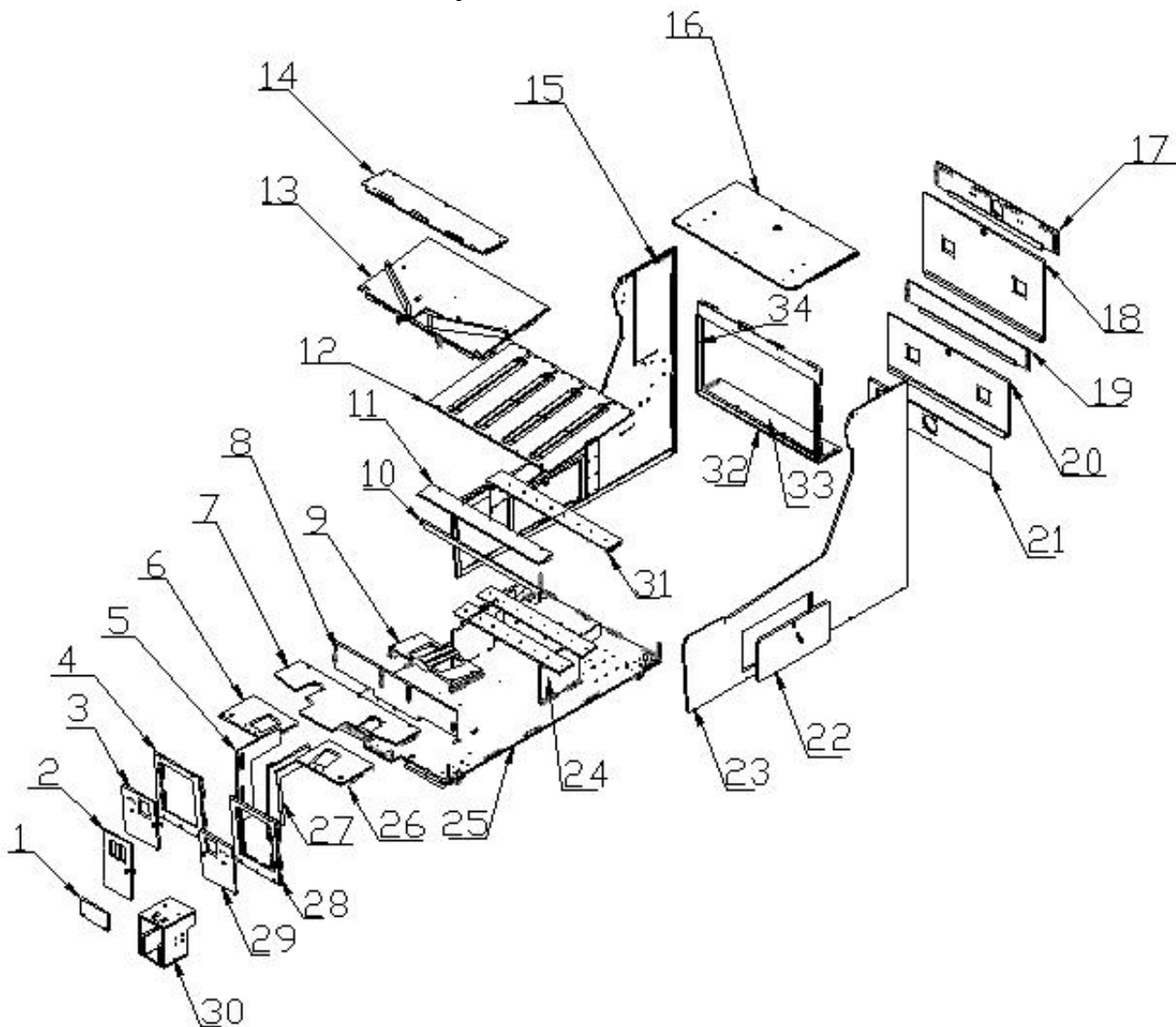

No.	Part No.	Code No.	Name	Qty
1	Z116-530-000	20341833A029	Middle lower board	1
2	Z116-529-000	20341833A028	Coin door	1
3	Z116-525-001	20341833A024A	L front door	1
4	Z116-523-001	20341833A022A	L front frame	1
5	Z116-527-000	20341833A026	Middle L board	1
6	Z116-521-000	20341833A020	L ctrl panel base board	1
7	Z116-518-000	20341833A017	Control panel board	1
8	Z116-520-000	20341833A019	Control panel back board	1
9	Z116-534-000	20341833A033	Send ball base board	1

No.	Part No.	Code No.	Name	Qty
10	Z116-512-000	20341833A011	Track front support board	1
11	Z116-516-000	20341833A015	Front support board	1
12	Z116-513-000	20341833A012	L track board	1
	Z116-514-000	20341833A013	Middle track board	3
	Z116-515-000	20341833A014	R track board	1
13	Z116-535-000	20341833A034	Base board	1
14	Z116-517-000	20341833A016	Upper board	1
15	Z116-502-000	20341833A002	L side board	1
16	Z116-508-000	20341833A007	Top board	1
17	Z116-507-000	20341833A006	Back top board	1
18	Z116-532-000	20341833A031	Back top door	1
19	Z116-506-000	20341833A005	Back middle board	1
20	Z116-531-000	20341833A030	Back bottom door	1
21	Z116-505-000	20341833A004	Back bottom board	1
22	Z116-533-000	20341833A032	Side door	2
23	Z116-503-000	20341833A003	R side board	1
24	Z116-536-000	20341833A035	Track support board	1
25	Z116-504-002	20341833A042	Base board	1
26	Z116-522-000	20341833A021	R ctrl panel base board	1
27	Z116-528-000	20341833A027	Middle R board	1
28	Z116-524-001	20341833A023A	R front frame	1
29	Z116-526-001	20341833A025A	R front door	1
30	Z116-501-000	20341833A001	Coin outer box	1
31	Z116-519-000	20341833A018	Track horizontal support board	1
32	Z116-509-000	20341833A008	Monitor background board	1
33	Z116-510-000	20341833A009	Monitor background base board	1
34	Z116-511-000	20341833A010	Monitor background front board	1

9.11 Decal Part

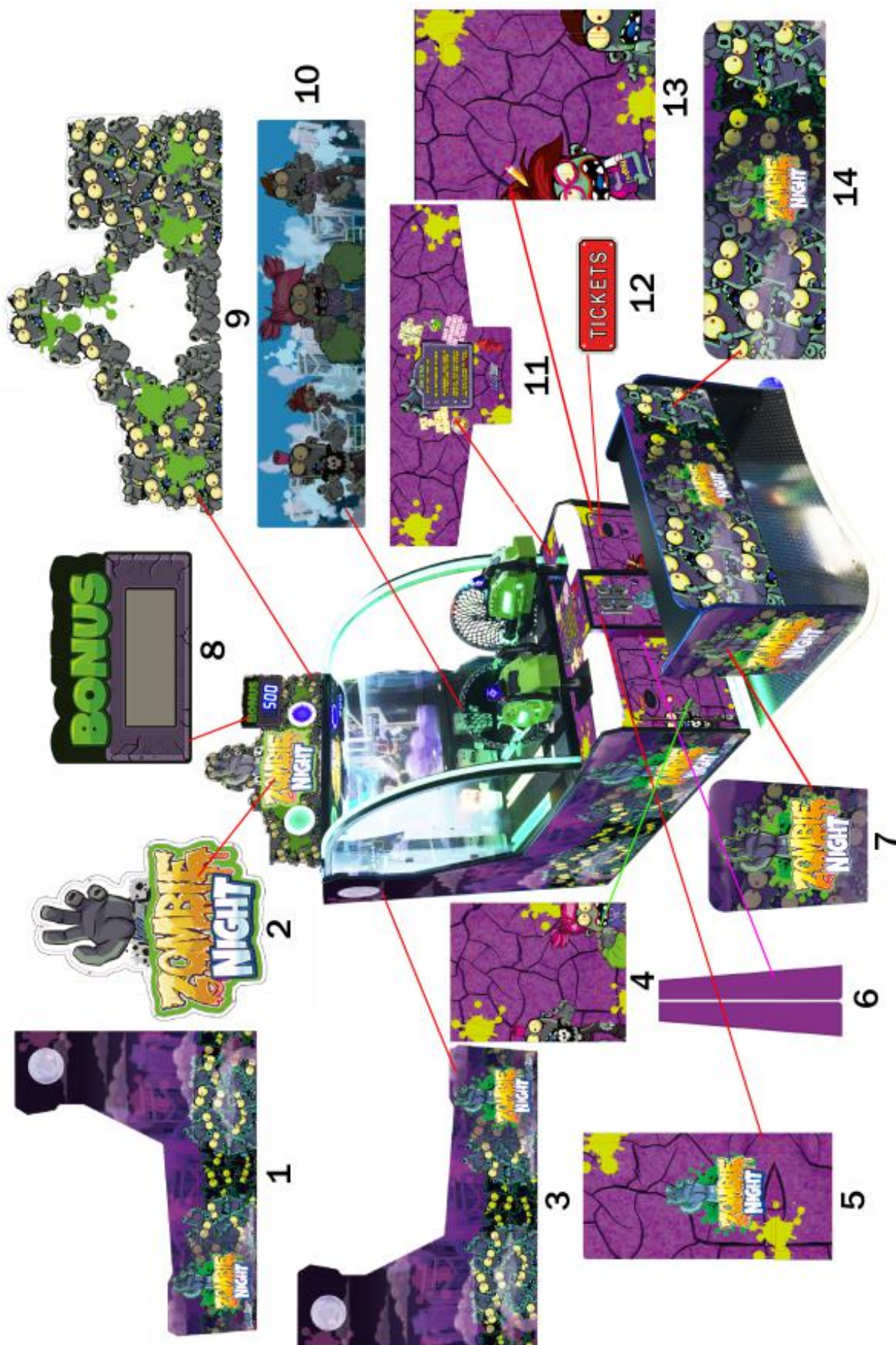

No.	Part No.	Code No.	Name	Qty
1	Z116-706-000	20541833A006	R side decal	1
2	Z116-701-000	20541833A001	Marquee plastic	1
3	Z116-705-000	20541833A005	L side decal	1
4	Z116-708-001	20541833A008A	L front door decal	1
5	Z116-710-000	20541833A010	Middle door decal	1
6	Z116-711-000	20541833A011	Middle side decal	1
7	Z116-712-000	20541833A012	Seat side decal	2
8	Z116-702-000	20541833A002	Display plastic	1
9	Z116-704-000	20541833004	Marquee background decal	1
10	Z116-703-000	20541833003	Toy background plastic	1
11	Z116-707-000	20541833A007	Control panel decal	1
12	Z116-722-000	25600000108	Ticket label	2
13	Z116-709-001	20541833A009A	R front door decal	1
14	Z116-713-000	20541833A013	Seat back decal	1

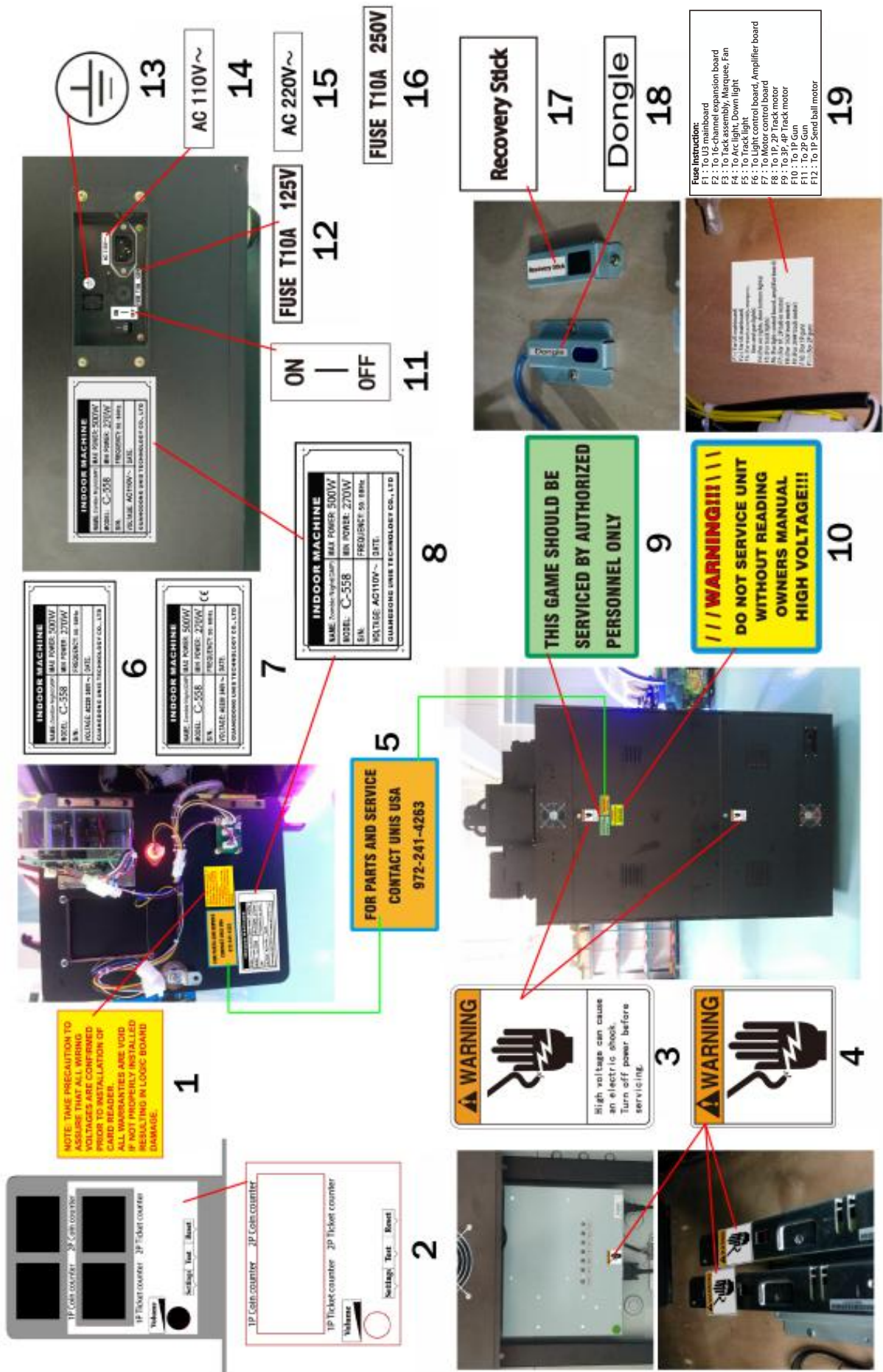

No.	Part No.	Code No.	Name	Qty
1	Z116-735-000	20511707K020	AAMA warning label	1
2	Z116-719-000	20541833A019	Counter label	1
3	Z116-725-000	25600000037	High voltage label(large)	2
4	Z116-724-000	25600000036	High voltage label(small)	3
5	Z116-734-000	25600000095	Service label(large)	2
6	Z116-715-000	20541833A015	220V nameplate	2
7	Z116-716-000	20541833A016	220V nameplate(CE)	2
8	Z116-714-000	20541833A014	110V nameplate	2
9	Z116-726-000	25600000042	Service label	1
10	Z116-727-000	25600000067	Warning label	1
11	Z116-723-000	25600000016	Switch label	1
12	Z116-731-000	25600000083	Fuse label	1
13	Z116-732-000	25600000091	GND label	1
14	Z116-728-000	25600000071	110V label	1
15	Z116-729-000	25600000072	220V label	1
16	Z116-730-000	25600000077	Fuse label	1
17	Z116-720-000	20541808018	Recovery stick label	1
18	Z116-733-000	25600000093	Dongle label	1
19	Z116-718-001	20541833A018A	Fuse instruction label	1

J01	J02	J03	J16	J17	J18	J20	J21	J22	J23	J24	J25	J26	J27	J28	J29	J32	J33
J35	J36	J37	J38	J39	J40	J41	J42	J43	J44	J45	J46	J47	J54	J55	J56	J57	J58
J65	J66	A	B	C	D	E	F	G	H	T1	T2	T3	T4	T5	T6	T7	T8
J01	J02	J03	J16	J17	J18	J20	J21	J22	J23	J24	J25	J26	J27	J28	J29	J32	J33
J35	J36	J37	J38	J39	J40	J41	J42	J43	J44	J45	J46	J47	J54	J55	J56	J57	J58
J65	J66	A	B	C	D	E	F	G	H	T1	T2	T3	T4	T5	T6	T7	T8
1P TICKET DISPENSER	2P TICKET DISPENSER	1P COIN MECH	2P COIN MECH	FUSEBOARD01 F10 (5A)	FUSEBOARD01 F11 (5A)	U3. PCB J1	U3. PCB J3	U3. PCB J4	U3. PCB J6	U3. PCB J7	U3. PCB J12	U3. PCB J17	U3. PCB J18	U3. PCB J19	U3. PCB J20	U3. PCB J21	U3. PCB J22
U3. PCB J23	A1. PCB J1	A1. PCB J5	A1. PCB VOL2	FUSEBOARD01 F1 (5A)	FUSEBOARD01 F2 (5A)	FUSEBOARD01 F3 (5A)	FUSEBOARD01 F4 (5A)	FUSEBOARD01 F5 (5A)	FUSEBOARD01 F6 (5A)	FUSEBOARD01 F7 (5A)	FUSEBOARD01 F8 (5A)	FUSEBOARD01 F9 (5A)	FUSEBOARD01 F12 (5A)	Output168 EXT.PCB J1	Output168 EXT.PCB J2	Output168 EXT.PCB J3	Output168 EXT.PCB J4
Output168 EXT.PCB J5	Output168 EXT.PCB J6	Output168 EXT.PCB J7	DMD-MB.PCB J1	DMD-MB.PCB J2	DMD-MB.PCB J4	DMD-MB.PCB J7	DMD-MB.PCB J9	DMD-MB.PCB J10	DMD-1.PCB J1	DMD-1.PCB J2	DMD-1.PCB J3	DMD-2.PCB J1	DMD-2.PCB J2	DMD-2.PCB J3	DMD-2.PCB J4	DMD-2.PCB J1	DMD-2.PCB J2
DMD-2.PCB J3	DMD-2.PCB J4	1P AAMA 12V	1P AAMA COIN	1P AAMA TICKET NOTCH	1P AAMA COIN INHIBIT	1P AAMA TICKET RUN	1P AAMA GND	2P AAMA 12V	2P AAMA COIN	2P AAMA TICKET NOTCH	2P AAMA COIN INHIBIT	2P AAMA TICKET RUN	2P AAMA GND	1P DBV AC-L	1P DBV AC-N	1P DBV SIGNAL	1P DBV GND
2P DBV AC-L	2P DBV AC-N	①40P	②80	⑥94	⑦70	⑧93	⑨A0P	①40P	②20	⑥92	⑦10	⑧91	⑨A0P	④10	⑥60	⑦20M	⑧A0
④10	⑥60	⑦30M	⑧A0														

1

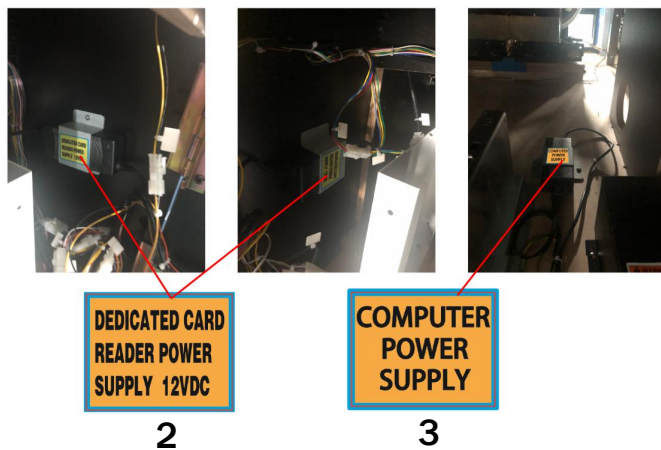

2

3

No.	Part No.	Code No.	Name	Qty
1	Z116-717-001	20541833A017A	Wiring labels	1
2	Z116-736-000	20511903B015	Adapter label	2
3	Z116-737-000	20511903B016	PC power supply label	1

9.12 Electrical Components

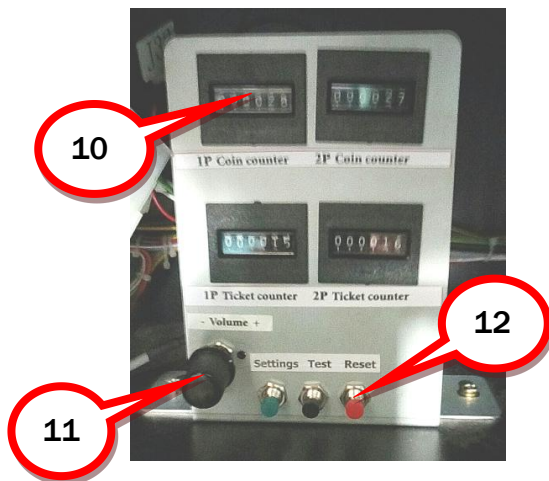
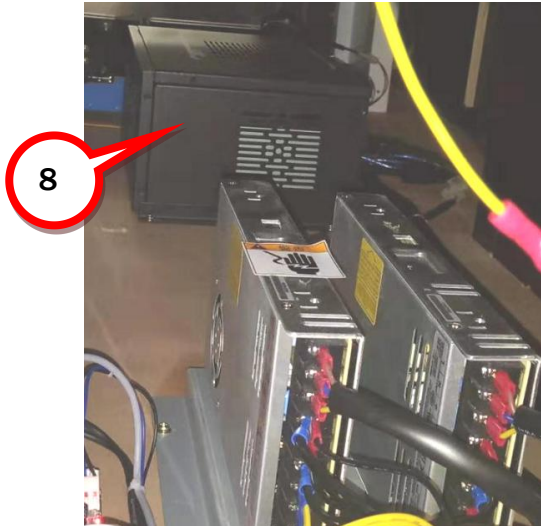
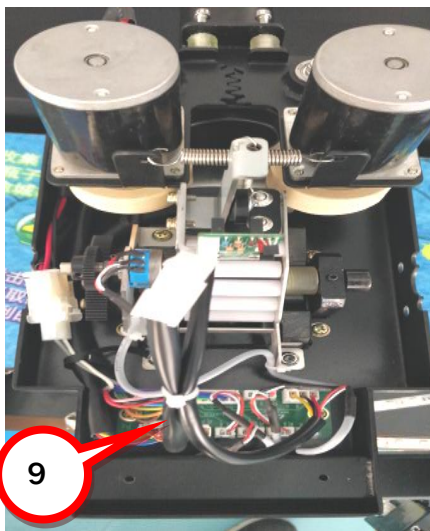
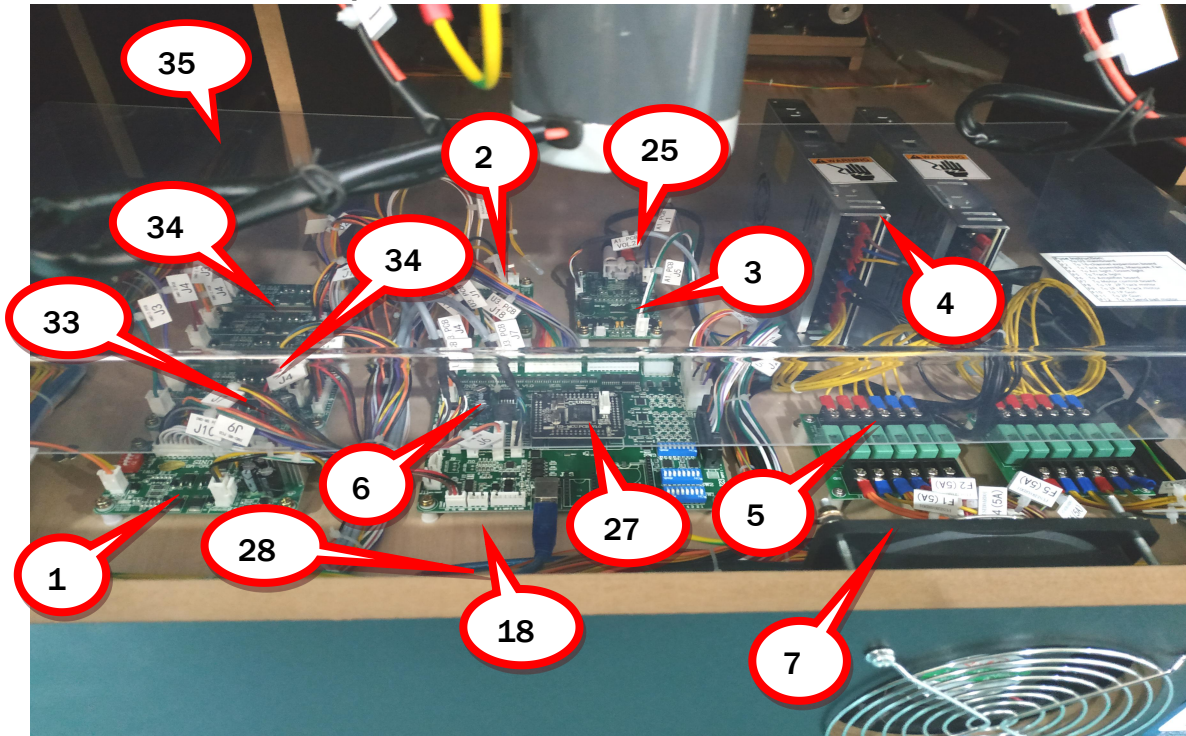

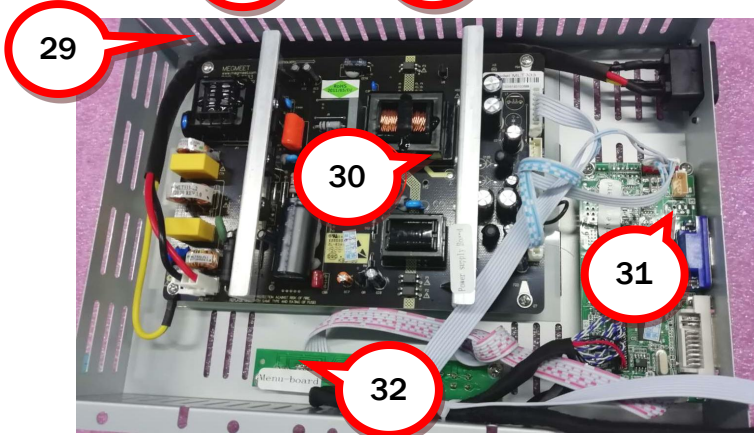
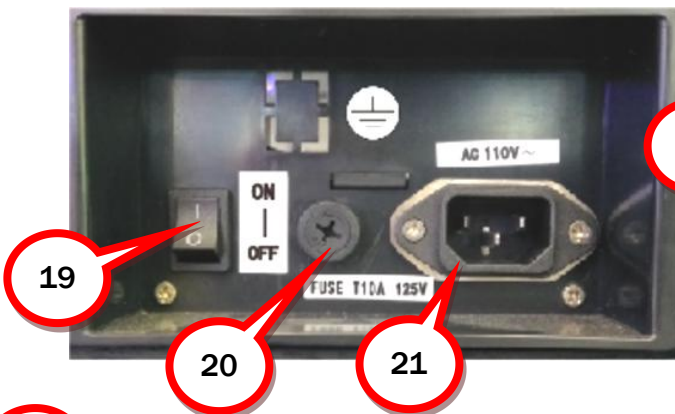
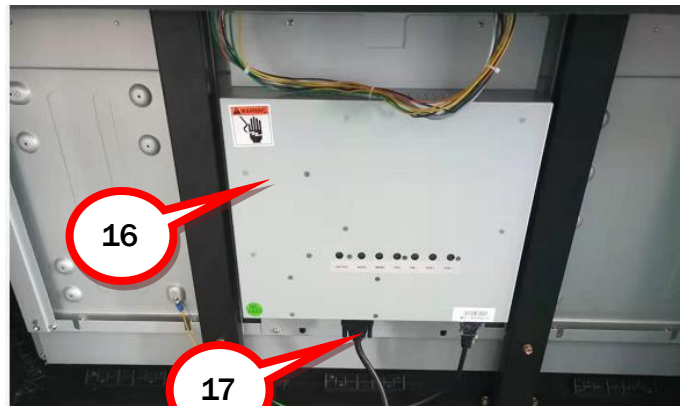
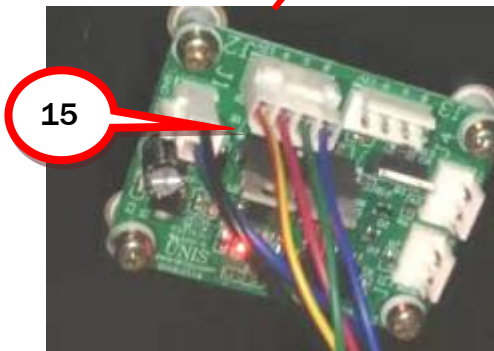
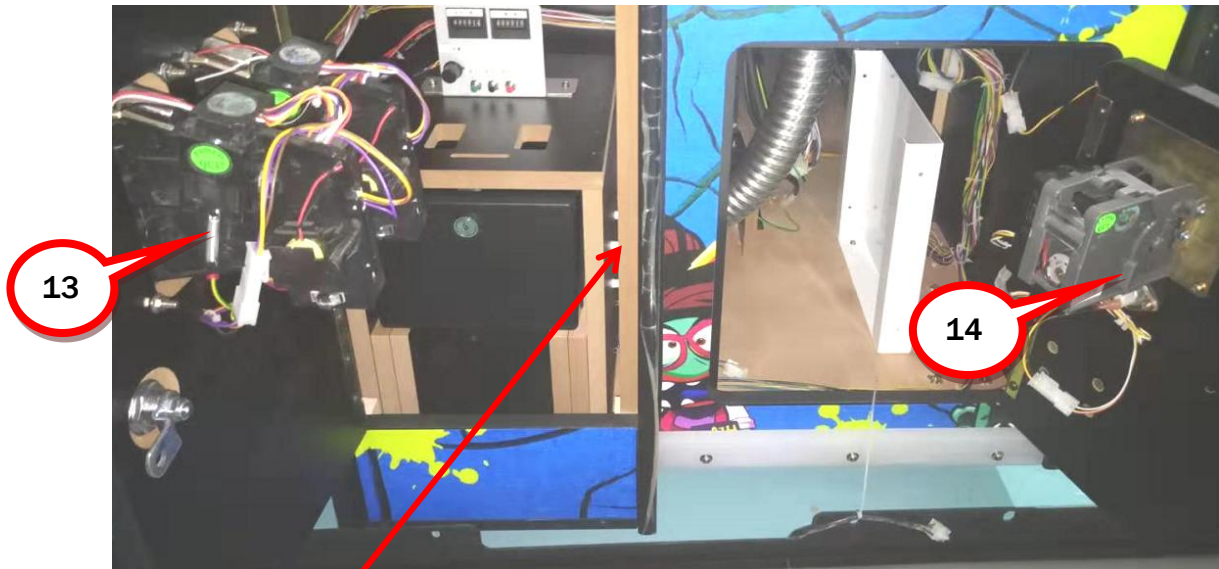

No.	Part No.	Code No.	Name	Qty
1	Z116-494-000	29741906002	Motor drive board	1
2	Z116-411-001	29711903001	16 extension board	1
3	Z116-412-000	29790300009	Amplifier board	1
4	Z116-416-000	21602000117	Power supply	2
5	Z116-420-000	21714000148D	Fuse board(green holder)	2
6	Z116-409-000	29790300003	U3 mainboard	1
7	Z116-451-000	22702010025	Fan	2
	Z116-452-000	22702000010	Fan net	4
8	Z116-401-000	21102000107	PC	1
	Z116-483-000	26601090479	Mainboard	1
	Z116-484-000	26601090480	Memory	2
	Z116-485-000	26601090481	HDD	1
	Z116-486-000	26601090482	CPU	1
	Z116-487-000	26601090483	PC case	1
	Z116-488-000	26601090484	PC power supply	1
9	Z116-434-000	29741833006	Converted board	2
10	Z116-426-000	23000000006	Counter	4
11	Z116-431-000	29791400001	POT connective board	1
	Z116-430-000	22403000001	Knob	1
12	Z116-427-000	22402010002	Button(red)	1
	Z116-428-000	22402030002	Button(green)	1
	Z116-429-000	22402050001	Button(black)	1
13	Z116-446-000	22301000002	Coin mechanism	2
14	Z116-447-000	23100000005	Ticket dispenser	2
15	Z116-413-000	29741606B002	Light control board	1
16	Z116-402-000	21201043003	43" monitor	1
17	Z116-408-000	23307020001D	DVI cable	1
18	Z116-405-000	23304000021	Cable	1
19	Z116-423-000	22601000005	Rocker switch	1
20	Z116-421-000	21901000013	Fuse	1
	Z116-422-000	21902000006	Fuse holder	1
21	Z116-424-000	23201000001A	Filter	1
22	Z116-406-000	23304030001	Extended cable	1
23	Z116-403-000	21107020036	Dongle	1
24	Z116-404-000	41300000007	Recovery stick	1
25	Z116-407-000	23305000003	Audio cable	1
26	Z116-417-000	21603000027	AC power adapter	1
27	Z116-410-000	29790300004	U3-MCU board	1
28	Z116-425-000	23309000324A	Cable set	1

No.	Part No.	Code No.	Name	Qty
29	Z116-489-000	26601090485	Chassis assembly of 43" monitor	1
30	Z116-490-000	26601090486	Power board	1
31	Z116-491-000	26601090487	Drive board	1
32	Z116-492-000	26601090488	Key board	1
33	Z116-493-000	29741906003	Motor drive board	1
34	Z116-495-000	29741922004	Motor drive board	2
35	Z116-243-001	20641833041A	Plastic cover	1



No.	Part No.	Code No.	Name	Qty
1	Z116-441-000	22003080026	5630 light	1
	Z116-442-000	22003080028	5630 light	2
2	Z116-435-000	29751301003	Speaker light board	2
	Z116-432-000	22801000055	Speaker	2
3	Z116-445-000	22002015021	BG5050RGB light strip	(59in x2) 1.5mx2
4	Z116-445-000	22002015021	BG5050RGB light strip	(23.6in x8) 0.6mx8
5	Z116-444-000	22002015019	BG5050W light strip	(21.6in x2) 0.55mx2
6	Z116-445-000	22002015021	BG5050RGB light strip	(15.7in x2) 0.4mx2
7	Z116-445-000	22002015021	BG5050RGB light strip	(98.4in) 2.5m
8	Z116-443-000	22002015017	BG5050B light strip	(1.96in x2) 0.05mx2
	Z116-438-001	29741833002A	Light board	2
9	Z116-441-000	22003080026	5630 light	1
	Z116-433-000	29741122003	Display	1
10	Z116-449-000	22003000003	LED bulb	2
	Z116-450-000	22201000028	Light holder	2
11	Z116-440-000	22003080044	5630 light	1
12	Z116-436-000	29741833007	Light board	4

NOTE: The installation of the DBV is to be completed by each individual location. (Not included)

10. WIRING DIAGRAM

