

# SERVICE MANUAL

# Lil Ticket Monsters



PLACE SERIAL NUMBER LABEL HERE

# FACTORY CONTACT INFORMATION



BAY TEK ENTERTAINMENT  
Pulaski Industrial Park  
1077 East Glenbrook Drive  
Pulaski, WI 54162 USA

**SIGN UP TO RECEIVE OUR E-MAILS!**

Stay up to date on the latest game information, new products launches, early notification of parts specials, updates of retro fit parts, software upgrades, best practices and more!

Visit [baytekent.com](http://baytekent.com) and enter your email to sign up!

You can also register your new game at [baytekent.com/register](http://baytekent.com/register)

**SALES**

Phone: (920) 822-3951

Fax: (920) 822-8936

Email: [baytek.sales@thevillage.bz](mailto:baytek.sales@thevillage.bz)

**PARTS**

Phone: (920) 822-3951 Ext 1101

Email: [baytek.parts@thevillage.bz](mailto:baytek.parts@thevillage.bz)

**SERVICE**

Phone: (920) 822-3951 Ext 1102

Email: [baytek.service@thevillage.bz](mailto:baytek.service@thevillage.bz)

**Open Monday - Friday  
8 AM - 5PM C.S.T.**

All games are proudly manufactured at our factory in Pulaski, Wisconsin, USA

# TABLE OF CONTENTS

FACTORY CONTACT INFORMATION .....	2
TABLE OF CONTENTS.....	3
WELCOME TO LIL' TICKET MONSTER .....	4
GAME SPECIFICATIONS .....	5
SAFETY PRECAUTIONS .....	6
REMOVEABLE MARQUEE .....	6
GAME SET UP .....	7 - 12
CARD SWIPE INSTALLATION .....	13
AVAILABLE BLANKING PLATES .....	13
GAME PLAY THEORY OF OPERATION .....	14
MAIN MENU FUNCTIONS .....	15
AUDIO SETTINGS .....	16
PAYOUT SETTINGS MENU .....	17
TICKET PATTERNS .....	18 - 19
GAME SETTINGS MENU .....	20
STATISTICS MENU .....	20
DIAGNOSTIC MENU .....	21
HOW TO LOCATE CIRCUIT BOARDS .....	22
DIPSWITCH SETTINGS .....	22
CIRCUIT BOARD LAYOUT .....	23
WIRING DIAGRAMS .....	24 - 28
TROUBLESHOOTING GUIDE .....	29 - 34
BILL ACCEPTOR DIAGNOSTICS .....	34
POWER SUPPLY DIAGNOSTICS .....	35
HOW TO CHANGE SOFTWARE .....	36
I/O AUX BOARD PINOUT .....	36
HOW TO OPEN FRONT PLEXI .....	37
HOW TO REMOVE ARROW SENSOR .....	37
HOW TO ADJUST ARROW SENSOR .....	38
HOW TO ADJUST BRAKE TENSION .....	38
HOW TO REMOVE HOME SENSOR .....	39
HOW TO REPLACE MONITOR .....	39
HOW TO REPLACE SOLENOID .....	40 - 42
HANDLE ASSY EXPLODED VIEW .....	43
DECAL DIAGRAM .....	44
PARTS LIST .....	45 - 46
PARTS PICTURES .....	47 - 49
MAINTENANCE LOG .....	50
TECHNICAL SUPPORT .....	51
WARRANTY .....	51

# WELCOME TO LIL TICKET MONSTER

## **Congratulations on your purchase!**

The beloved Lil' Monsters : Burb, Grunt and toot are delighted to be a part of your game room! The Lil' Monsters are fun and friendly to all age groups, creating multi-generation appeal to anyone that steps through your doors!

Please take a moment to read through this manual and be sure to contact us if you have any questions, or would like more information.

Thank you for your purchase!

Your business is important to us and we hope you enjoy this game as much as we do!

*Your Friends at Bay Tek Entertainment*



## **GAME INSPECTION**

Please inspect the game for any damaged, loose, or missing parts.

If damage is found, please contact your freight carrier first.

Then, contact Bay Tek Entertainments' Service Department at  
(920) 822-3951 Ext. 1102

Or email us at [baytek.service@thevillage.bz](mailto:baytek.service@thevillage.bz) for further assistance.

# GAME SPECIFICATIONS

## WEIGHT

NET WEIGHT	386 lbs.	175 kg
SHIP WEIGHT	471 lbs.	214 kg

## GAME DIMENSIONS

WIDTH	30.75 inches	79 cm
DEPTH	43 inches	110 cm
HEIGHT	106.25 inches	270 cm

## OPERATING TEMPERATURE

FAHRENHEIT	45 - 80 F
CELSIUS	7.2 - 26.7 C

## SHIPPING DIMENSIONS

PALLET	60"L x 40"W x 92"H , 471 lbs. class 125
--------	---

## POWER REQUIREMENTS

INPUT VOLTAGE RANGE	100 to 120 VAC	220 to 240 VAC
INPUT FREQUENCY RANGE	60 Hz	50/60 Hz

## MAX OPERATING CURRENT

2.8 Amps @ 115 VAC / 1.4 Amps @ 230 VAC

Note: The marquee artwork can be removed to lower game to 7' 6". (90 inches)

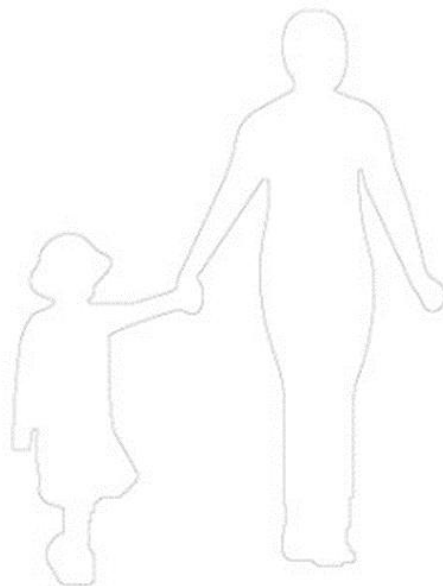

# SAFETY PRECAUTIONS

<b>NOTICE</b>
Modifications to the mechanical, electrical and structural components of this game may void its compliance certifications.
This appliance is suitable for INDOOR, DRY locations only.
<b>DANGER</b>
DO NOT perform repairs or maintenance on this game with the power ON. Unplug the unit from the wall outlet or shut off the power strip located inside the cabinet.
<b>WARNING</b>
Use of flammable substances can cause sever burns or serious injury. Always use NON-FLAMMABLE solvents for cleaning. DO NOT use gasoline kerosene or thinners.
<b>CAUTION</b>
Lifting heavy objects can cause back, neck or other injuries. Be sure adequate lifting and moving devices are available when unloading, unpacking and moving this game.
<b>ATTENTION</b>
Be sure the electrical power matches the game requirements. See the serial number located on the back of the game cabinet. Always plug into a grounded circuit. If the supply cord is damaged, it must be replaced by an approved cord or assembly provided by the manufacturer. <b>A shielded power cable must be used for the game to retain EU/EMC compliance.</b>
<b>IN CASE OF EMERGENCY</b>
UNPLUG THE POWER CORD. The power cord must be accessible at all times in case of an emergency.
<b>WARNING</b>
This unit is capable of producing sound levels hazardous to human hearing. Consult local sound regulations and adjust volume accordingly.

# REMOVABLE MARQUEE

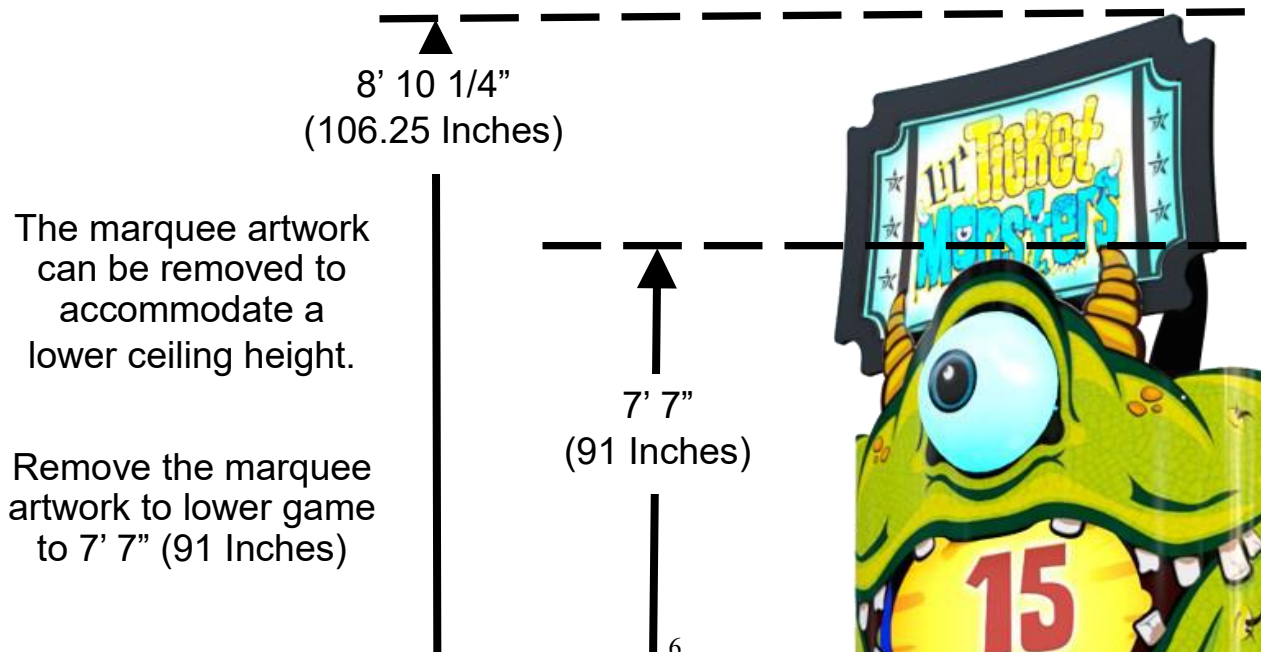

# LIL TICKET MONSTER GAME SETUP

The game will arrive on one pallet.  
Please inspect the pallet for shipping damage and report immediately to the freight company if any damage is found.



Remove the cardboard from the pallet.

Carefully remove the plastic wrap securing the printed plexi wrapped to the side of the cabinet. Save this printed plexi for later installation.

Remove the large plastic bag from the cabinet and proceed to assembly instructions.



## **Tools Needed:**

1 step ladder (4-6 foot)      #2 square bit screwdriver      11/32" wrench  
9/16" wrench                      Phillips screwdriver

Remove the protection plastic from the front plexi.

Remove the keys from the small plastic bag taped to the top console.

Unlock the front door using a H95 key.



## **Important!**

Remove the **first of 2 shipping bolts** using a 9/16" wrench.

There is another shipping bolt accessed from the back door.

Unlock the coin box door using a A05/E00 key.



Remove the hardware kit (Part # A5KIT-LTM), wood blocks and service manual from the coin box.

Remove the eyeball light to be installed later.

Close and lock coin box door, remove key to allow the front door to close fully.



# LIL TICKET MONSTER GAME SETUP

Hardware kits consist of:

32 of A5SCPH151 used to install the eyeball light and printed plexi wrap.  
 2 of A5SCPH230 and 2 of A5NULO030 used to secure plexi wrap below monitor.

1 of A5BOHH060, 1 of A5WASI020, and 1 of A5WAFL060 are to be saved with the wood blocks and used to support the wheel in case of a future solenoid replacement.



A5SCPH151



A5NULO030



A5SCPH230



A5BOHH060



A5WASI020



A5WAFL060

Unlock the back door using a H95 key.

Remove the back door by using both handles to lift upwards and pull out.

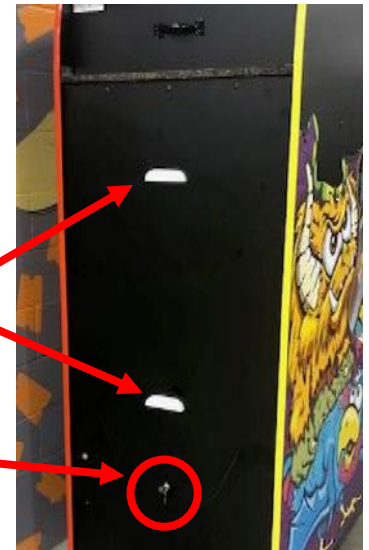

## Important!

Remove the 2nd of 2 shipping bolts using a 9/16" wrench.

Ensure the shipping bolt from the front door is also removed.

Replace the back door and remove the game from the pallet.

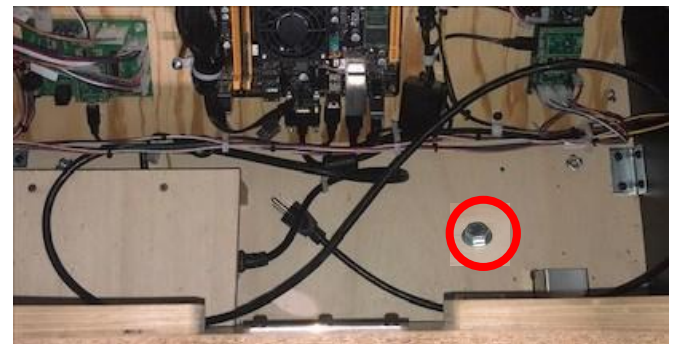

Using a ladder, carefully position the eyeball light on top of the game by positioning it inline with pilot holes.

Secure using 2 of the black screws from the hardware kit using a #2 square bit screwdriver.



A5SCPH151

Connect the CE22506 cable from eyeball light to the game cable CE22505 located in the top of the game.

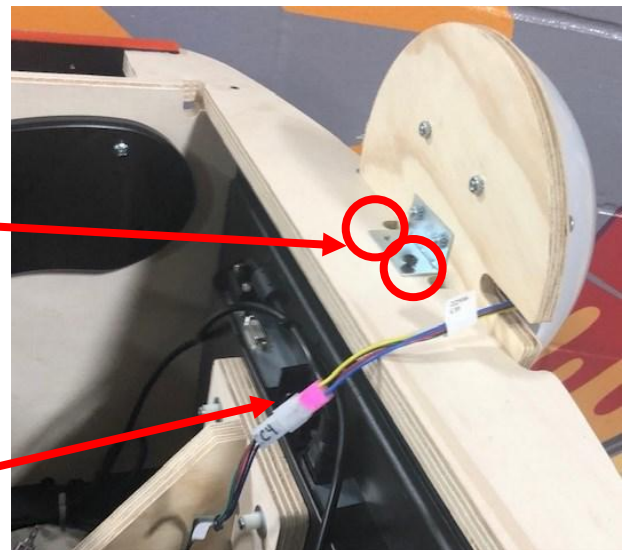



# LIL TICKET MONSTER GAME SETUP

## Rotate upper marquee in place:

Remove the lower bolt (A5BOPH320) from both left and right sides of marquee arm.  
Leave the top bolt in place.



Rotate the marquee upward and re-insert the same bolts previously removed into the left hole.

Do this on both arms of the marquee.



## Install the printed plexi wrap.

Remove the clear protective film from both sides of the printed plexi wrap.

The idea is to secure **one** screw into the left side of the plexi, then wrap it around the game and install screws into the right side.

The first screw to be installed will be this one. Line up the printed plexi with this pilot hole and insert 1 of the black screws from the hardware kit using a #2 square bit screwdriver.



A5SCPH151

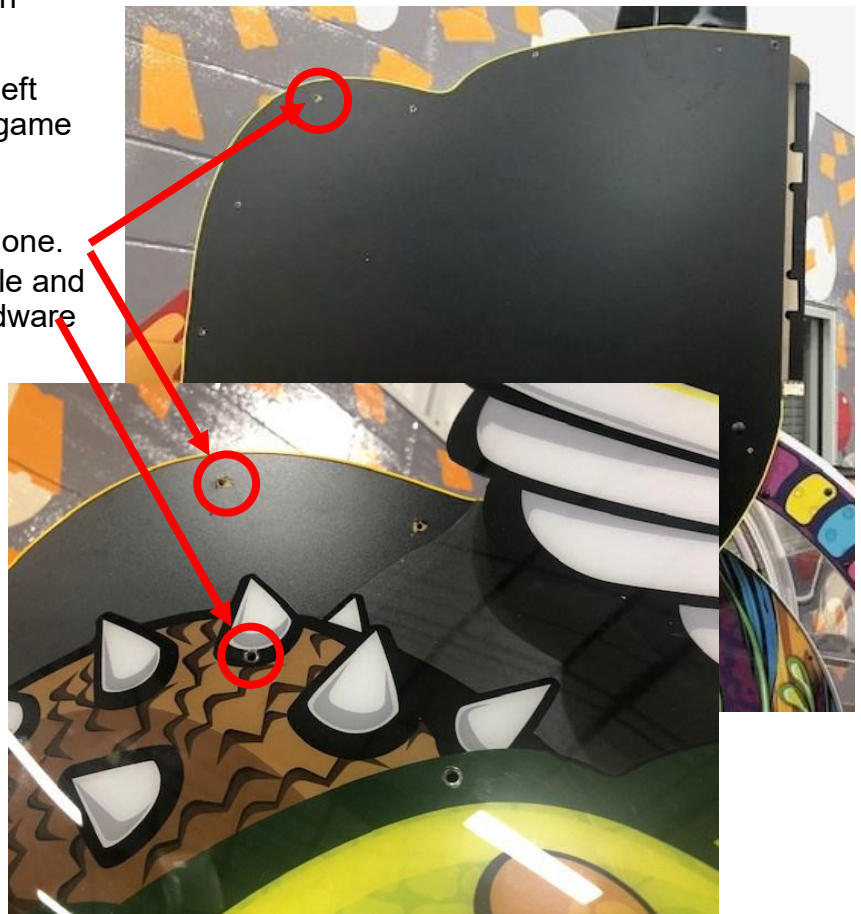

# LIL TICKET MONSTER GAME SETUP

Pull the printed plexi wrap around the front of the game tightly, with the eyeball light through the round cutout in the plexi.

Continue wrapping the top of the cabinet and get ready to insert one screw in this location.

Line up the printed plexi with this pilot hole and insert 1 of the black screws from the hardware kit using a #2 square bit screwdriver.



A5SCPH151

Make sure the bolt hole is centered in the hole of the printed plexi.

Pull the printed plexi snugly until this bolt is centered in the hole of the printed plexi.

Insert another of the black screws from the hardware kit using a #2 square bit screwdriver.



A5SCPH151

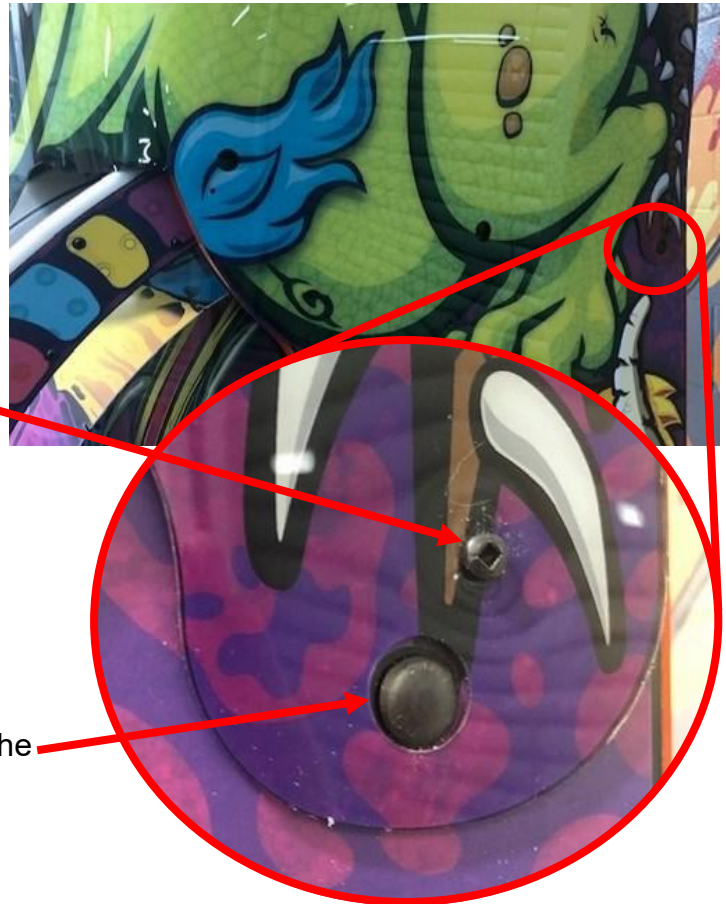

# LIL TICKET MONSTER GAME SETUP

Continue installing the black screws from the hardware kit using a #2 square bit screwdriver in both the left side and right side printed plexi wrap.



A5SCPH151

There are a total of 15 screws in each side.

If the plexi bulges in spots, it may be necessary to remove screws close to bulge and re-install screws.



# LIL TICKET MONSTER GAME SETUP

Install the 2 center bolts and nuts under the monitor.

The printed plexi wrap is secured to small “L” brackets using a Phillips bolt and nut from the hardware kit.



A5NULO030



A5SCPH230



Push the 2 bolts through the printed plexi, through the hole in the “L” bracket, and secure with the nut by reaching under the lip of the plexi.

Secure using a Phillips screwdriver and 11/32” wrench.

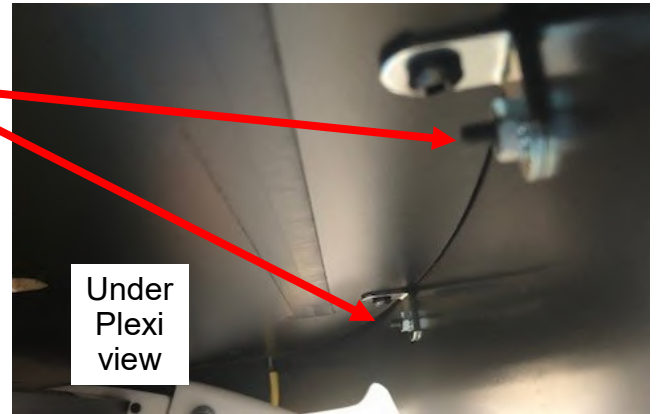

Remove the power cord from the coin box, and thread the power cord through this hole, out the rear of the cabinet and plug into a grounded outlet.



Power on game:

Open the front door and turn on the rocker switch on the power strip along the right side of coin box.

The rocker switch is located behind the 1st power cord on the strip



The game is now set up and ready for play!

Enter menu to adjust settings to your location specific price per play and ticket payout.



This unit is capable of producing sound levels hazardous to human hearing.

Consult local sound regulations and adjust volume accordingly.

# CARD SWIPE SYSTEM INSTALLATION

The Lil Ticket Monster game is pre-wired with an UCL (Universal Card Link) connector to accept Card Swipe systems from many different manufacture's.

Please follow these instructions to make full use of this capability.

## Option #1:

Card swipe systems may come with a standard 9 pin Molex connector. This is the UCL connector. Simply plug this connector into your card swipe reader.

## Note:

- Many card swipe systems have a voltage threshold that can be adjusted in the card swipe menu. Please set this "Game Drive Threshold" to 2 Volts.

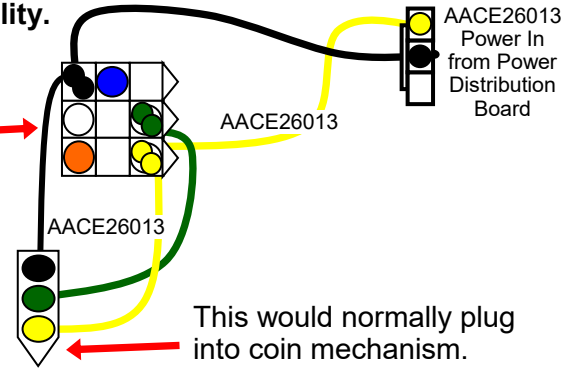

## Option #2:

If your card swipe systems does not have a standard 9 pin Molex connector, then you will have to splice wires into the AACE26013 harness.

Black wire is ground. (common)  
Green wire is coin signal.  
Yellow wire is +12 Volts DC

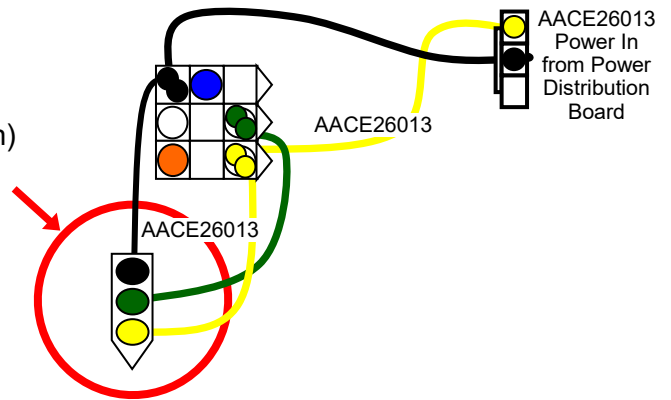

## Menu Changes

- Enter menu, go to "Payout" Menu
- Verify "Credits" set to 1
- Verify "Card Reader" set to "Enabled"

Check dipswitches on the I/O Aux Board in the front of game. Verify Dipswitch # 5 ON

# AVAILABLE BLANKING PLATES



A5PL4200 DBA Plate for 12V Upstacker Bill Acceptor



A5PL9998 Plate used instead of Coin Mechanisms



A5PL8900 Plate used for Bill Validator



A5PL9995 Plate used instead of ticket dispenser

# GAME PLAY THEORY OF OPERATION

The game is designed to give tickets after the player lifts, then pushes down on the plunger handle.

Upon coin up, the solenoid on the left side of the wheel will engage and provide a mechanical link from the plunger handle to the wheel.

As the plunger is pushed down, the wheel will start spinning.

The solenoid will stay engaged, allowing the player to plunge again to spin faster until a “Good Spin” wheel speed is achieved.

Once the wheel is spinning at or above this “Good Spin” wheel speed, the solenoid will disengage.

The “Good Spin” wheel speed is measured by the Wheel Encoder Sensor located in the arrow in the right front of the wheel.

This Wheel Encoder Sensor also detects the notched edge around the right edge of the wheel to determine how far away it is from the “Home Position”.

The “Home Position” is kept track of by the Home Sensor located on the right side of the wheel. The Home Sensor (accessed from the back of the game) sees a reflection from a metal tab mounted on the wheel, seeing the reflection once per rotation.

This calculation of the Wheel Encoder Sensor and the Home Position Sensor allows the game to determine which position the wheel lands on and provides that amount of tickets to the player.



# MAIN MENU FUCTIONS

The Menu and Menu Select buttons are located inside the front door.

Hold the MENU button down for 1 second to open the main menu on the monitor.

Press MENU to scroll through the options, and MENU SELECT to change the settings.



MAIN MENU		
<b>Clear Credits and Tickets</b>	Press the MENU SELECT button 5 times to clear credits and tickets owed	
<b>Mute</b>	ON (No sound from game)	OFF
<b>Attract and Volume</b>	Press MENU SELECT to enter the Attract and Volume Settings Menu	
<b>Payout</b>	Press MENU SELECT to enter the Payout Settings Menu	
<b>Game Settings</b>	Press MENU SELECT to enter the Game Settings Menu	
<b>Statistics</b>	Press MENU SELECT to enter the Statistics Menu	
<b>Diagnostics</b>	Press MENU SELECT to enter the Diagnostic Menu	
<b>Exit</b>	Press MENU SELECT button to exit menu	

\*\*\* Default settings are highlighted in yellow



Software versions are shown on the bottom left corner of the main menu screen.

**Software Version: 1.3**  
**Doorboard Version: 1.7**  
**Wheelboard Version: 1.2**  
**Lightboard Version: .1**

If "Not Found" is displayed, then the circuit board is not communicating to motherboard.

Door Board Version: Not Found

# ATTRACT AND VOLUME MENU

Scroll through the options by pressing the "MENU" button.

Change selection with the "SELECT" button.

Scroll to "BACK" and press the "SELECT" button to go back to the main menu.

Default settings are highlighted in yellow below.

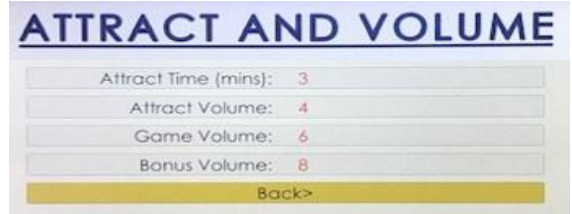

## ATTRACT TIME

DISABLED	1	2	3	4	5	6	7	8	9	10
----------	---	---	---	---	---	---	---	---	---	----

Sets the amount of minutes between the attract mode cycles.

"DISABLED" means that there will be no attract sounds.

## ATTRACT VOLUME

OFF	1	2	3	4	5	6	7	8	9	10
-----	---	---	---	---	---	---	---	---	---	----

Sets the attract volume on a sliding scale. OFF means no attract volume.

## GAME VOLUME

OFF	1	2	3	4	5	6	7	8	9	10
-----	---	---	---	---	---	---	---	---	---	----

Sets the game volume on a sliding scale. OFF means no game play volume.

## BONUS VOLUME

OFF	1	2	3	4	5	6	7	8	9	10
-----	---	---	---	---	---	---	---	---	---	----

Sets the bonus celebration volume on a sliding scale. OFF means no bonus celebration volume.



# PAYOUT SETTINGS MENU

Scroll through the options by pressing the “MENU” button.  
 Change selection with the “SELECT” button.  
 Scroll to “BACK” and press the “SELECT” button to go back to the main menu.

Default settings are highlighted in yellow below.

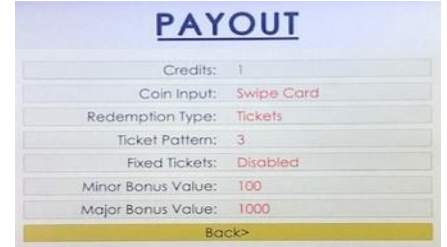

## CREDITS

FREE	1	2	3	4	5	...	17	18	19	20
------	---	---	---	---	---	-----	----	----	----	----

Sets the amount of credit pulses needed to start a game.  
 “Free Game” means the game will always be in play mode.

## CARD SWIPE

SWIPE CARD	TAP CARD	INSERT CREDITS
------------	----------	----------------

Shows the verbiage on the screen to match your locations setup.

## REDEMPTION TYPE

COUPONS	TICKETS	POINTS
---------	---------	--------

Sets the wording that will show on the screen for the player.

## TICKET PATTERN

FIXED TICKETS	1	2	3	4
---------------	---	---	---	---

Sets the ticket pattern for game play. Available patterns are described on the next page.  
 Default is \$1.00 per game.

## FIXED TICKETS

Disabled	1	2	3	4	5	...	24	25
----------	---	---	---	---	---	-----	----	----

Sets the amount of tickets that will be given if the player **only** if “Ticket Pattern” is set to Fixed Tickets

## MINOR BONUS VALUES

15	50	100	250
----	----	-----	-----

Sets the amount of tickets for the 3 minor bonus locations on the wheel.

## MAJOR BONUS VALUE

50	100	250	500	1000	2000
----	-----	-----	-----	------	------

Sets the amount of tickets for the 1 major bonus location on the wheel.

# TICKET PATTERNS

There are 4 base ticket patterns to choose from. These base patterns can be adjusted by adding cover-up decals to the wheel over the minor and major bonus values. Base ticket values and minor and major bonus values can be changed in the "Payout Settings Menu". Tickets per game shown are average payout over time.

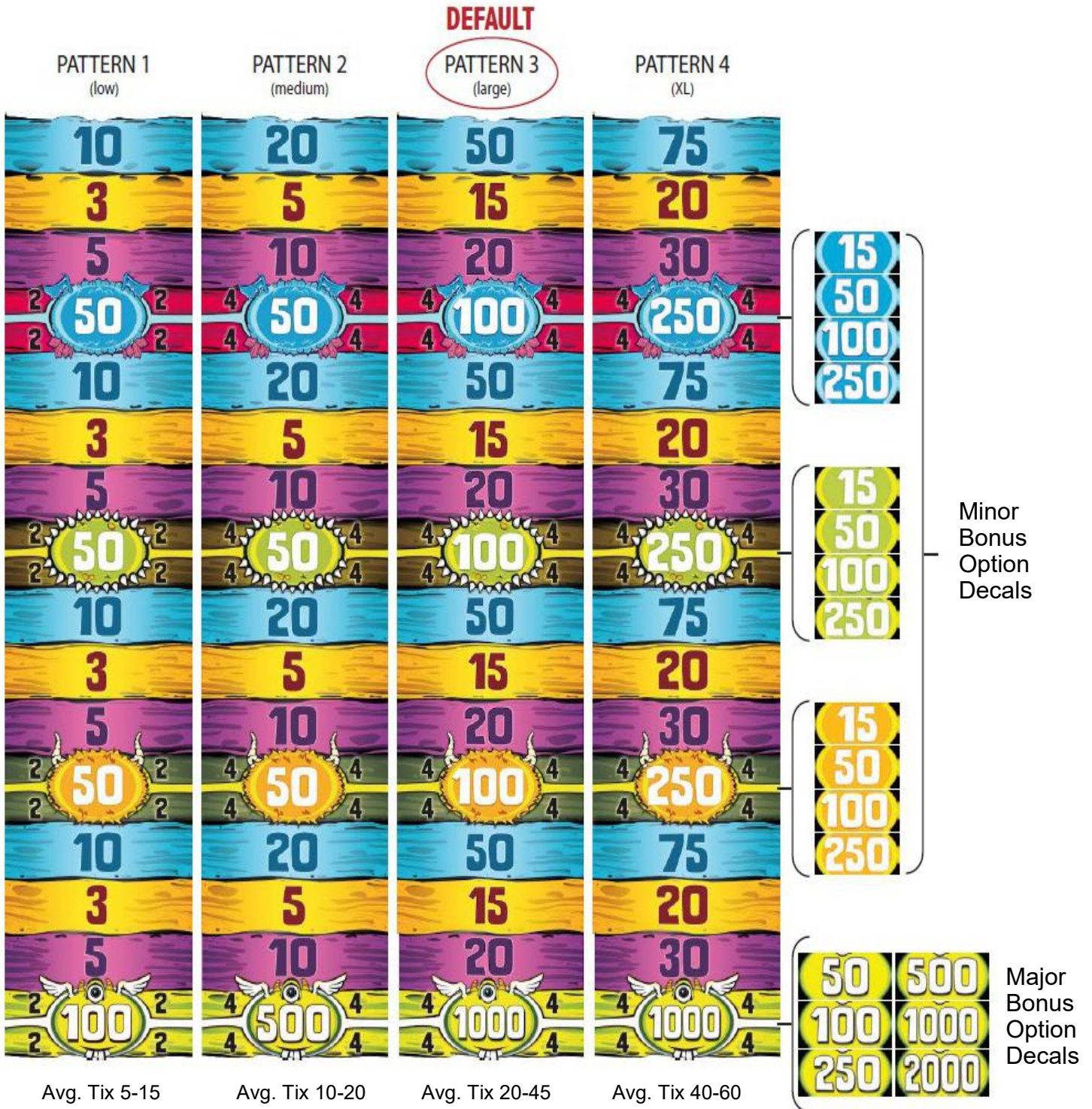

# TICKET PATTERNS

There are 4 base ticket patterns to choose from. These base patterns can be adjusted by adding cover-up decals to the wheel over the minor and major bonus values. Base ticket values and minor and major bonus values can be changed in the "Payout Settings Menu" Tickets per game shown are average payout over time.

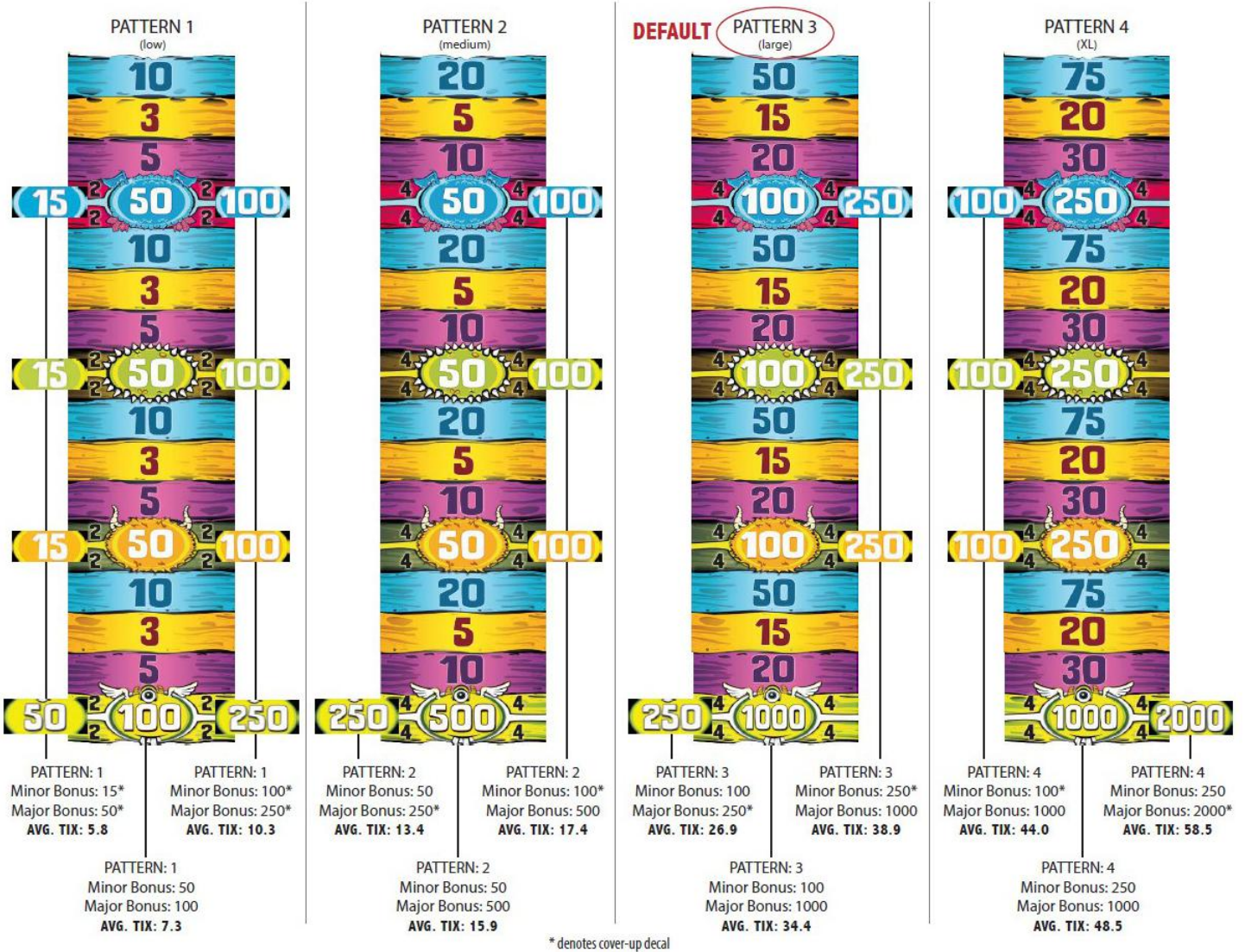

## How to change ticket payout:

The tickets per game can be modified by purchasing a set of cover up decals and placing them over the existing number on the wheel. Order part # AADE22510



# GAME SETTINGS MENU

Scroll through the options by pressing the "MENU" button.

Change selection with the "SELECT" button.

Scroll to "BACK" and press the "SELECT" button to go back to the main menu.

Default settings are highlighted in yellow below.

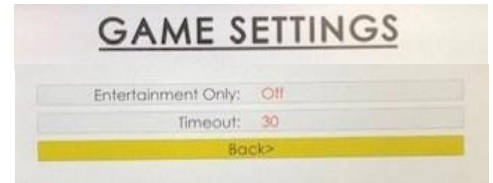

## ENTERTAINMENT ONLY

OFF

ON

"ON" will not dispense tickets.

## TIMEOUT

Disabled	30	60	90	120	...	300
----------	----	----	----	-----	-----	-----

Sets the amount of seconds that the game will wait for the player to spin the wheel.

After this amount of time, the game will award 4 tickets and go to "Game Over"

"Disabled" is no timeout - Required for WA State -

# STATISTICS MENU

Scroll through the options by pressing the "MENU" button.

The Statistics Menu displays the:

- Total Games Played
- Total Game Time
- Average Game Time
- Number of Game Timeouts
- Total Tickets Dispensed
- Average Tickets Dispensed Per Game
- Total Bonus Tickets Dispensed



Clear Statistics - Press the "SELECT" button 5 times to Reset Statistics.

Scroll to "BACK" and press the "SELECT" button to go back to the main menu.

# DIAGNOSTIC MENU

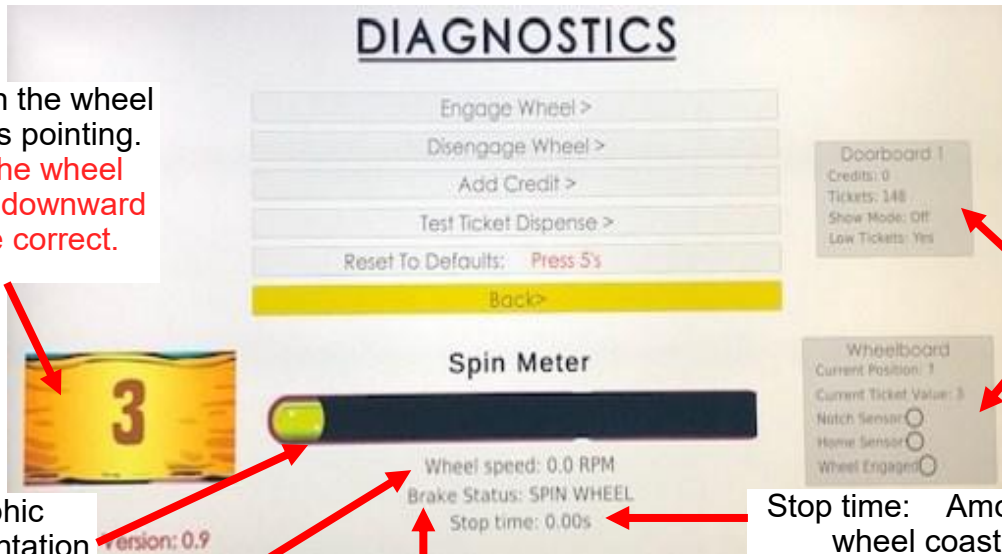

Ticket value on the wheel where arrow is pointing.  
**Important: The wheel must be spun downward for this to be correct.**

Explained on the bottom of this page.

Graphic representation of wheel speed as it's turning.

Revolutions Per Minute of wheel as it's turning.

Brake Status: Give the wheel a fast spin and allow it to coast to a stop. This will show "Brake OK" when brake is set correctly.

Stop time: Amount of time the wheel coasts to a stop

## ENGAGE WHEEL

Press the "Menu Select" button to engage the solenoid. This will allow the wheel to turn by pushing the plunger down.

## DISENGAGE WHEEL

Press the "Menu Select" button to un-power the solenoid.

## ADD CREDIT

Will send one credit pulse to game when the "Add Credit" option is selected.

## TEST TICKET DISPENSER

Will send one ticket enable pulse to dispenser when the "Dispense Tickets" option is selected.

## RESET TO DEFAULTS

All Menu Options will change to the Factory Default settings when selected.

Doorboard 1  
 Credits: 0  
 Tickets: 148  
 Show Mode: Off  
 Low Tickets: Yes

"Doorboard 1" sections will show:  
 Total amount of credits in memory  
 Total amount of tickets owed.  
 Status of the "Show Mode" dipswitch on the I/O board.  
 Status of the low ticket switch.

Wheelboard  
 Current Position: 7  
 Current Ticket Value: 3  
 Notch Sensor:   
 Home Sensor:   
 Wheel Engaged:

"Wheelboard" sections will show:  
 Current position of wheel (From 0-32)  
 Current Ticket Value - The ticket value that arrow is pointing at.  
 "Notch Sensor" will light as the encoder sensor sees a notch as the wheel is turning.  
 "Home Sensor" will light as the home sensor sees the metal bracket on side of wheel  
 "Wheel Engaged" will light when the game thinks it is sending power to the solenoid.

# HOW TO LOCATE CIRCUIT BOARDS

All circuit boards can be accessed from the back door of the game.

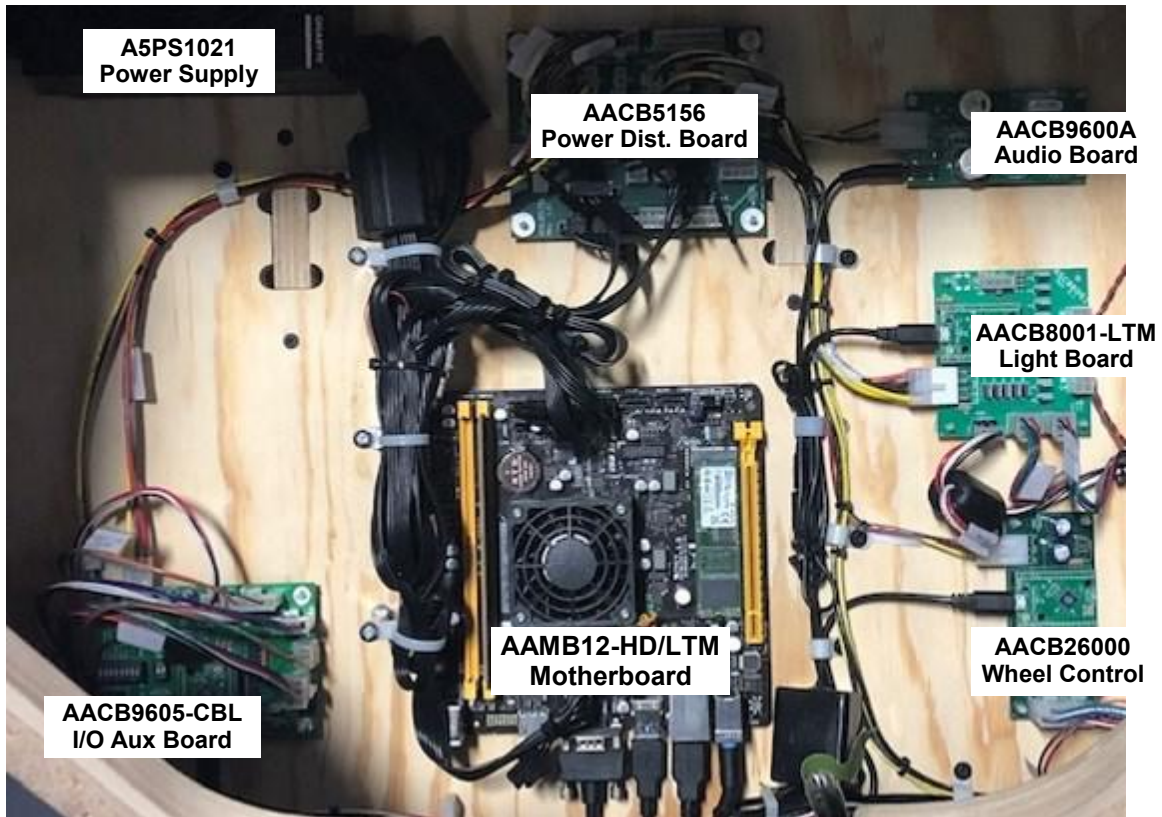

## DIPSWITCH SETTINGS

SWITCH	DESCRIPTION	ON	OFF
1	<b>SHOW GAME</b> Does not dispense tickets and clears all accumulated credits		X
2	<b>AMUSEMENT ONLY</b> Does not dispense tickets		X
3	<b>NJ LOCKOUT</b> Saves tickets owed and unused credits after a power loss		X
4	<b>1/2 TICKET PAYOUT</b> Dispenses 1/2 the amount of tickets as shown on screen. It will round up odd amounts of tickets		X
5	<b>DISABLES LOW TICKET INPUT</b> Disables the low ticket message on screen. This option should be enabled when using a card swipe system		X
6	<b>NOT USED</b>		
7	<b>NOT USED</b>		
8	<b>NOT USED</b>		

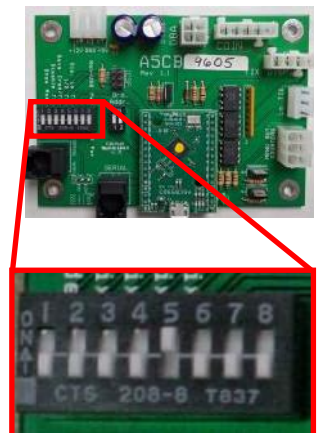

**Note:**  
UP is ON

# CIRCUIT BOARD LAYOUT

**Note:** All boards are located in the back of the game.

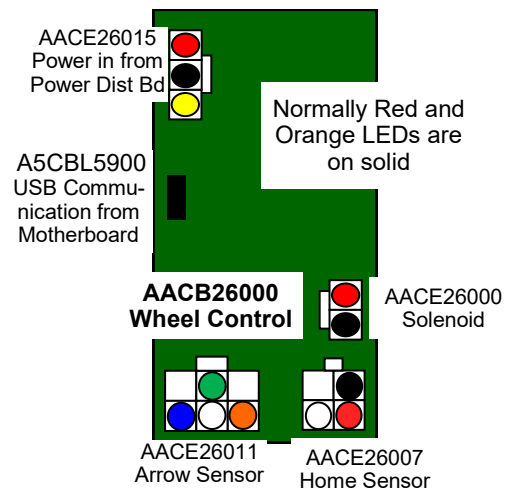
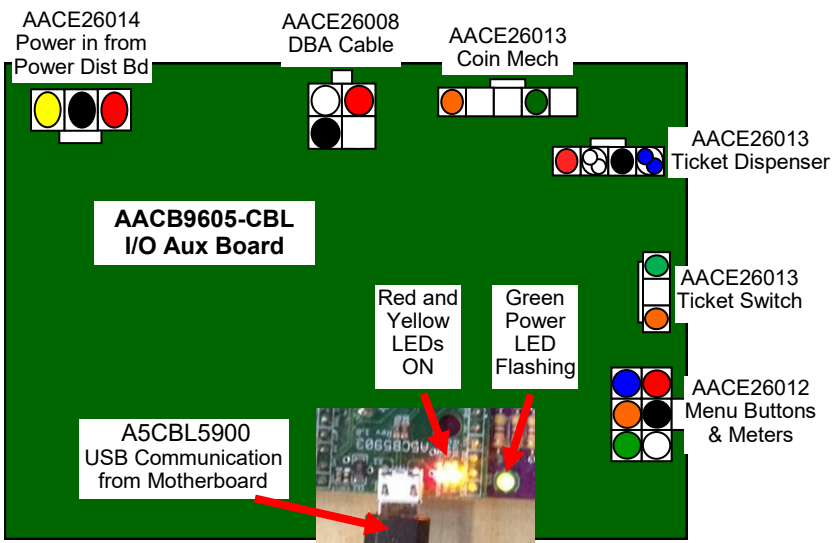
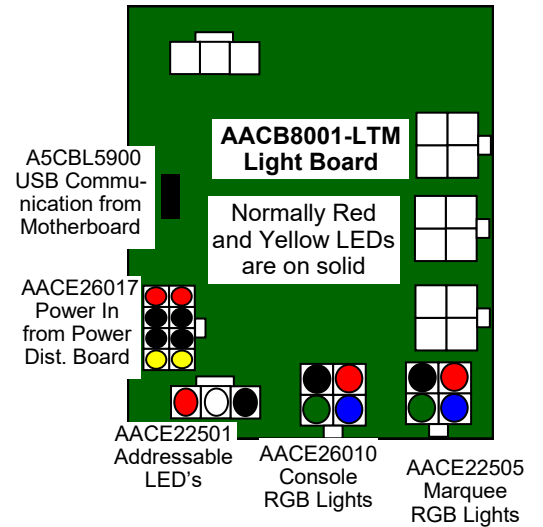
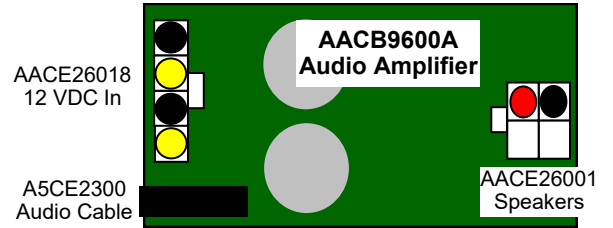
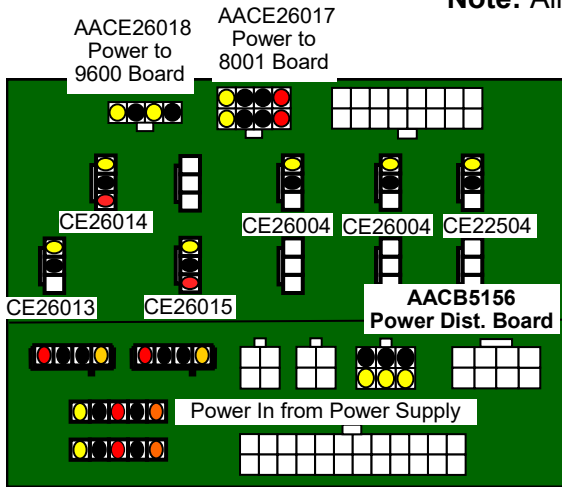

# MOTHERBOARD LAYOUT

There are 2 different versions of motherboards that work with Little Ticket Monster.

The original MB12 motherboard used a M.2 Hard Drive

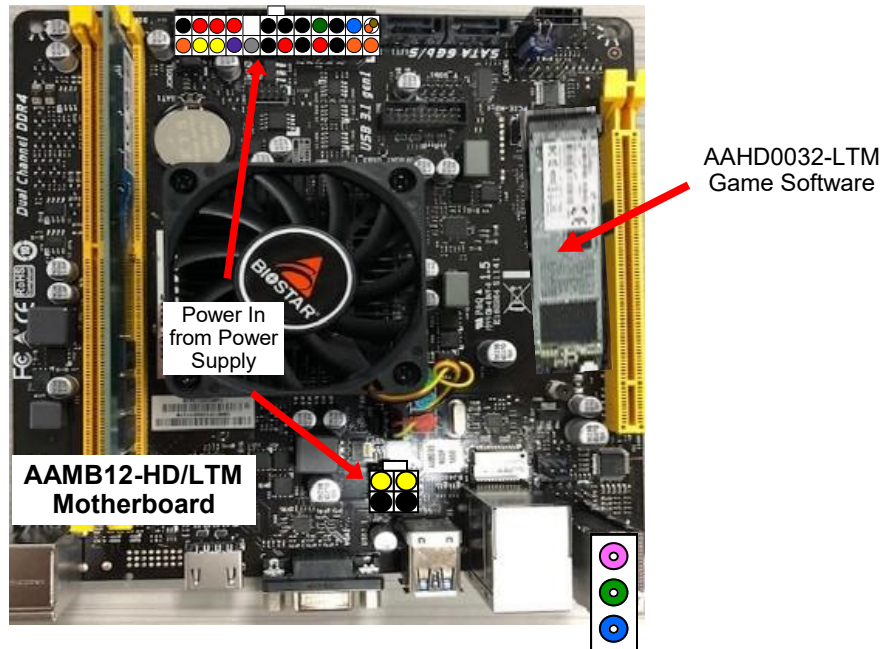

Starting in March, 2023 the newer MB13 motherboard also uses a M.2 Hard Drive Located on the bottom, underneath the motherboard.

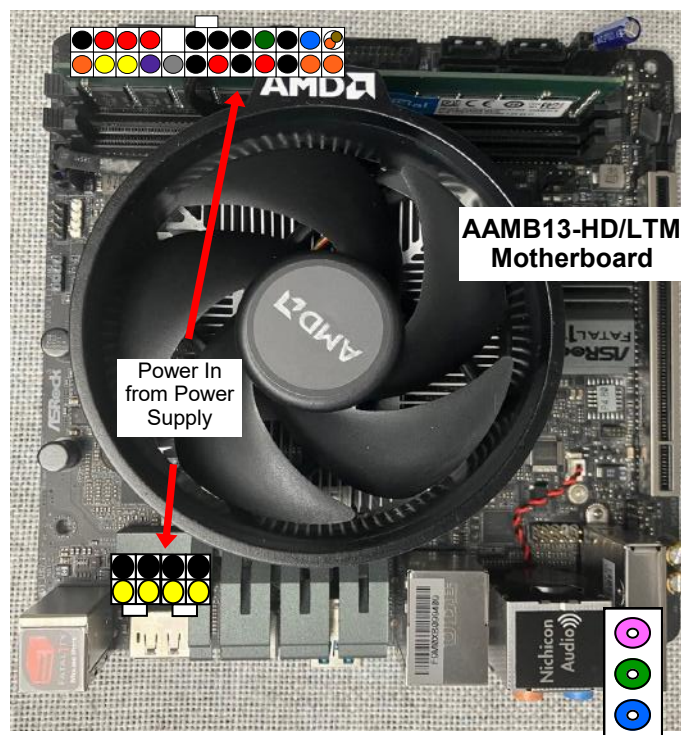



# FRONT DOOR WIRING DIAGRAM

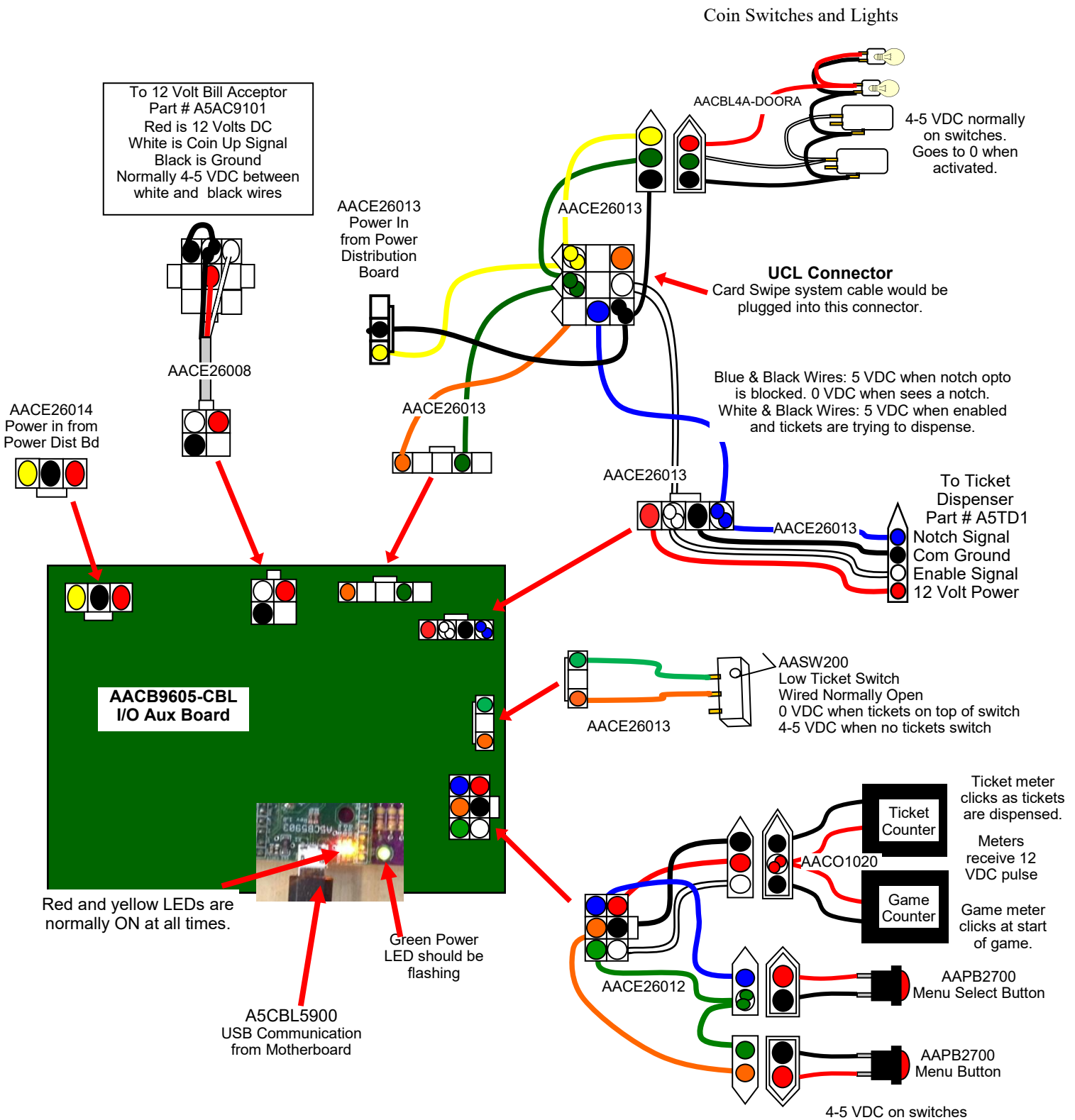

# WHEEL CONTROL BOARD WIRING DIAGRAM

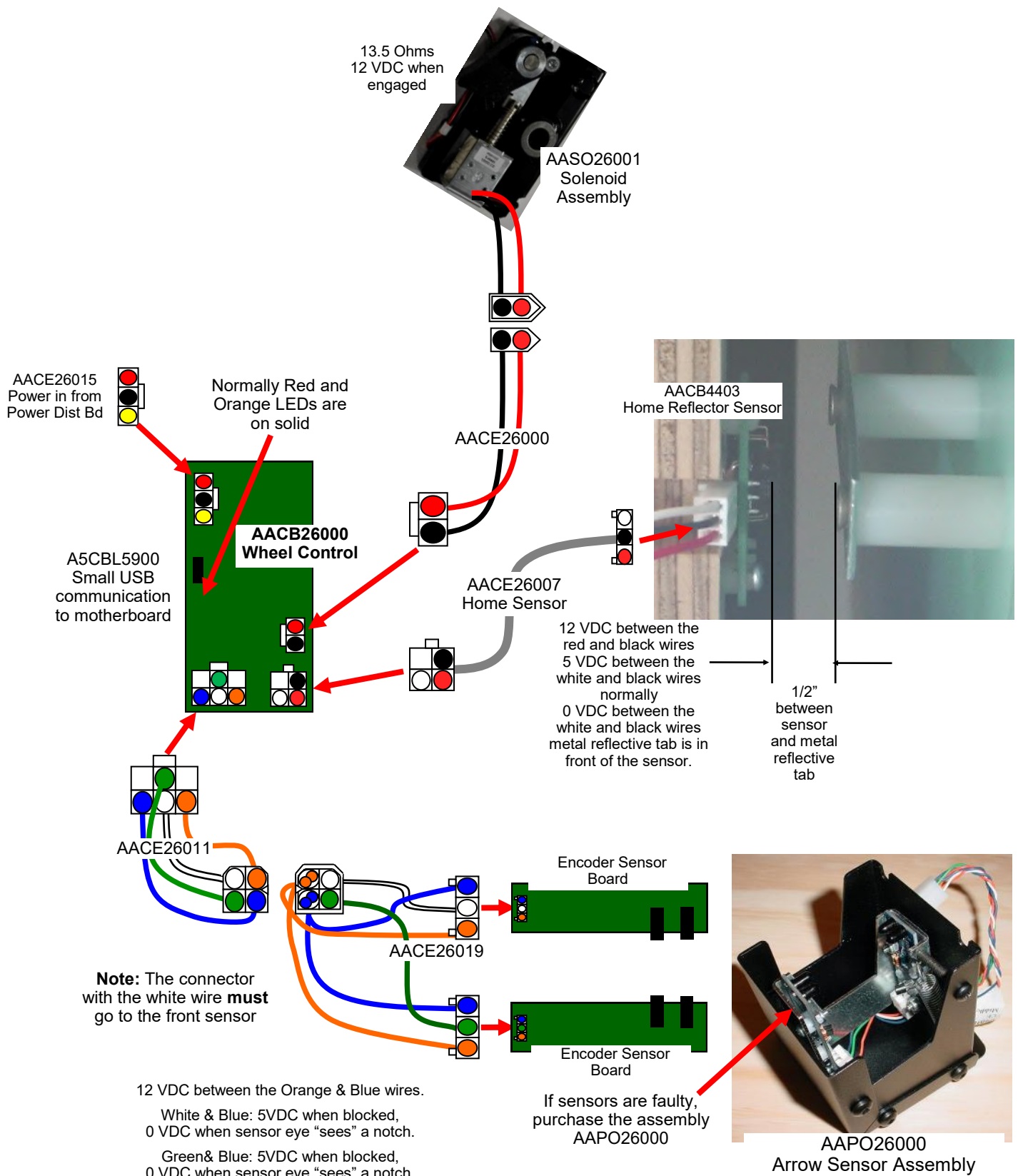

# LIGHTING WIRING DIAGRAM

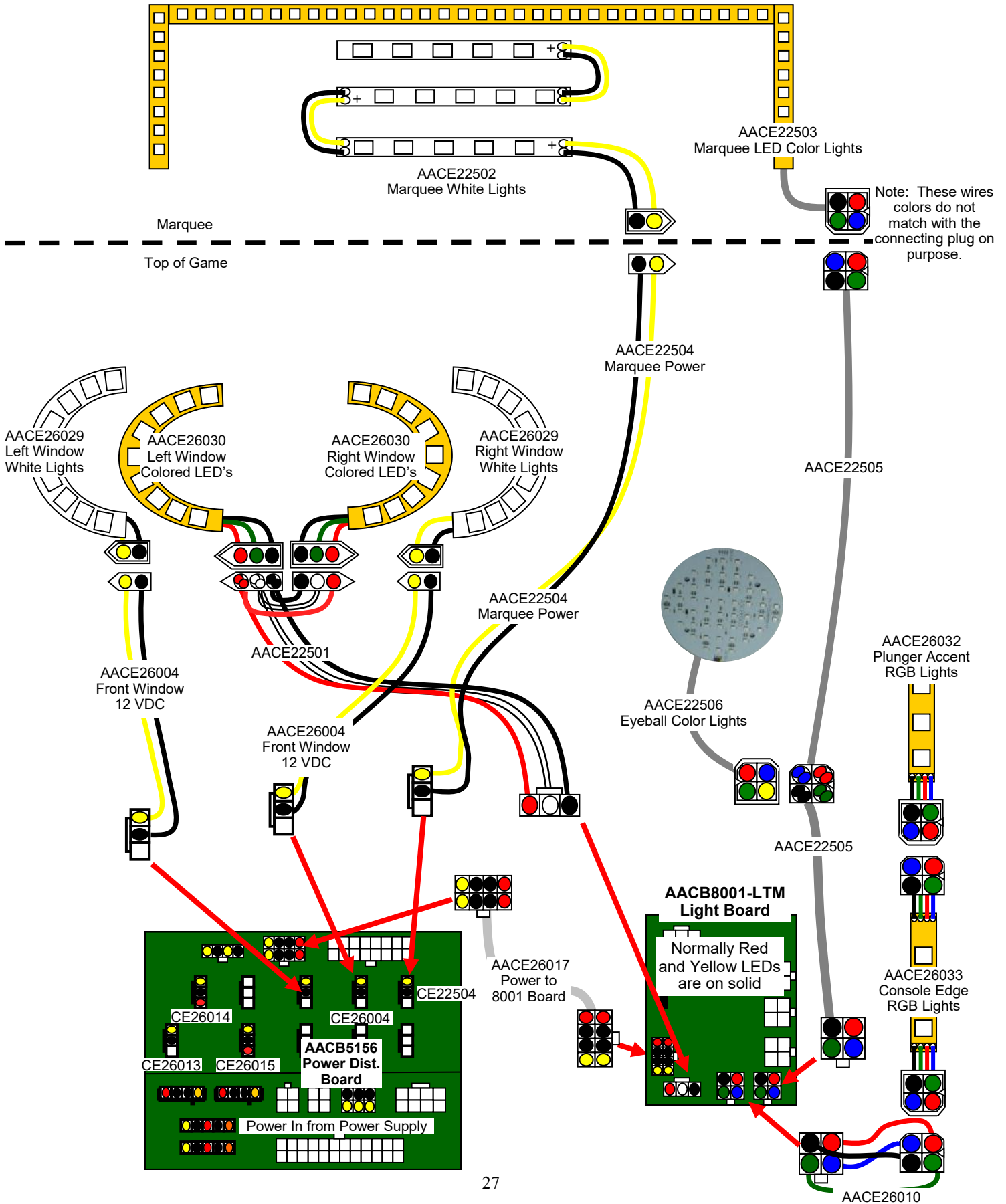

# SPEAKERS AND MOTHERBOARD COMMUNICATION

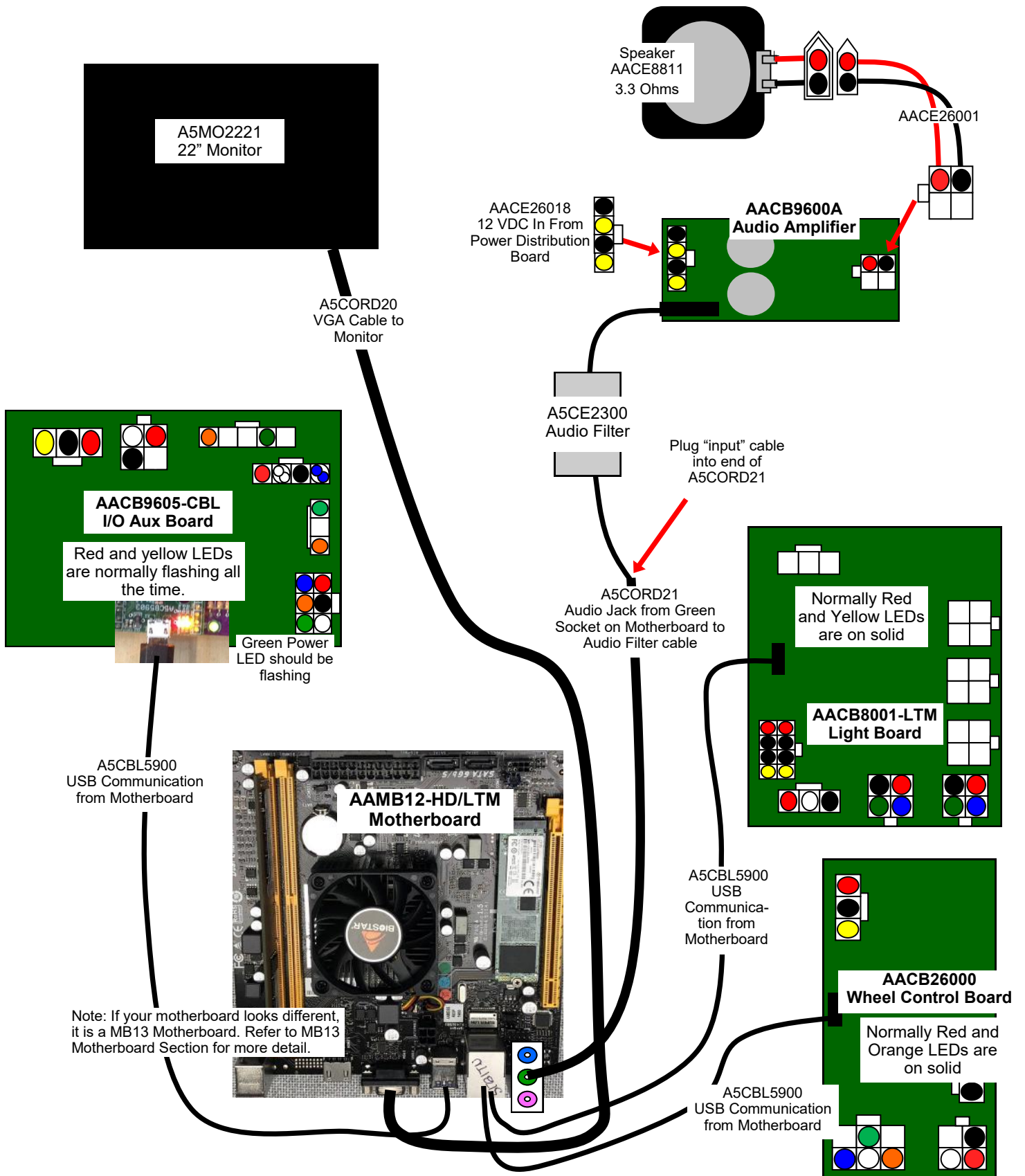

# AC IN & DC VOLTAGE WIRING DIAGRAM

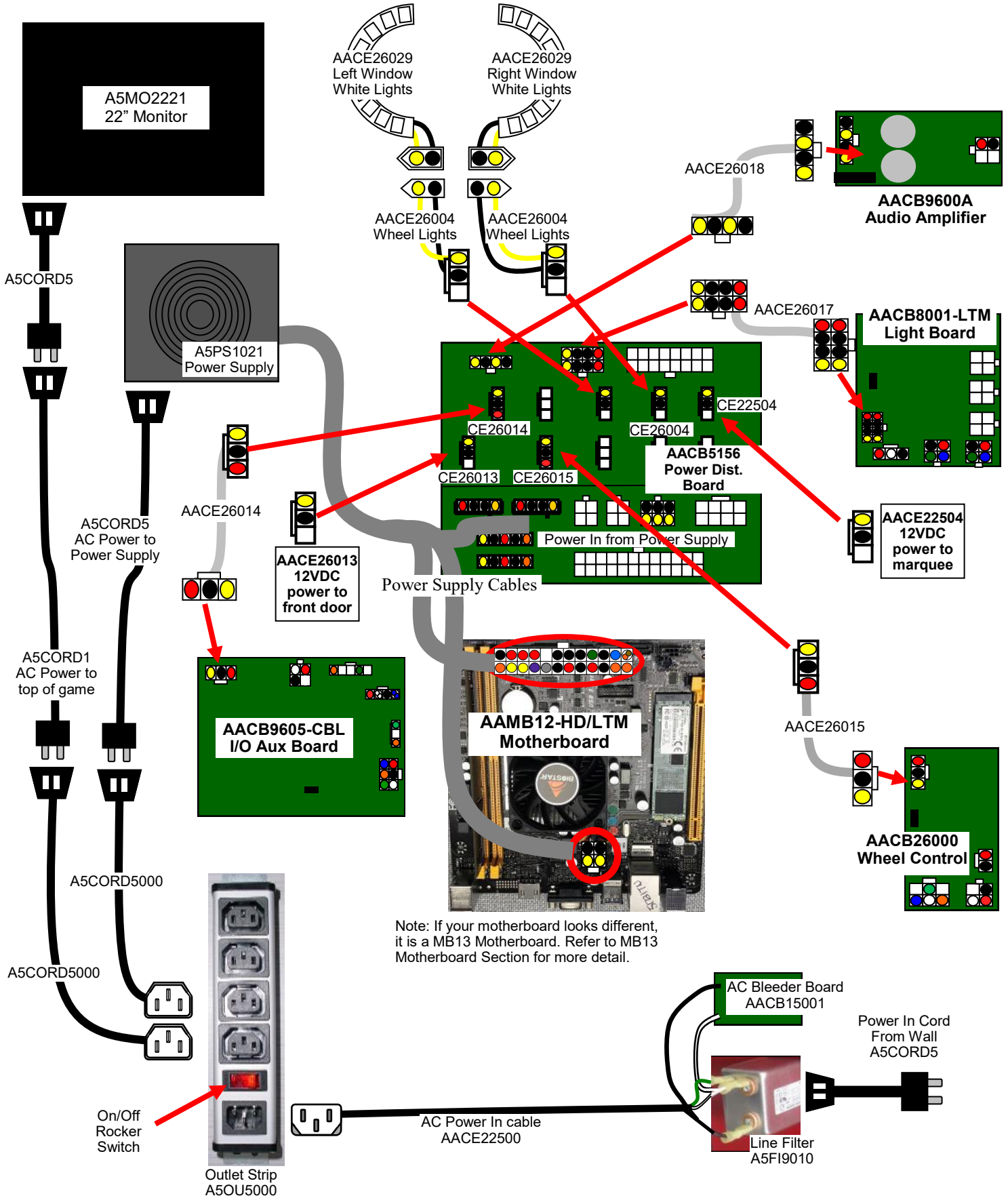

# TROUBLESHOOTING GUIDE

## Troubleshooting Strategy



Use common sense and a systematic method of troubleshooting to determine the exact problem, probable cause and remedy. Use the process of elimination to find the faulty component. Always check for the simple and obvious causes

Troubleshooting Chart		
Problem	Probable Cause	Remedy
<p><b>No power to the game</b> <b>No lights on at all</b></p>	<p>Unplugged. Circuit breaker tripped. Line Filter Faulty. Power strip faulty. Faulty cable/power supply</p>	<p>Check wall outlet. Reset power strip breaker switch or building circuit breaker. Replace Line Filter (Part # A5FI9010) Swap positions, ensure rocker switch on power supply is ON, replace if needed A5OU5000 Refer to wiring diagram. Check cables CE22500 &amp; CB15001 board. Refer to Power Supply diagnostic section</p>
<p><b>Monitor on, but everything else off</b>  <b>(Power Supply not ON)</b></p>	<p>Power supply unplugged. Rocker Switch. Power supply shutting down because of 12 V overload. Faulty power supply. Faulty Power Dist Board</p>	<p>Ensure unit is plugged into power strip. Make sure rocker switch on power supply is set ON. Refer to power supply diagnostics to isolate bad component. A bad solenoid or 12 volt short would cause this. Refer to Power Supply Diagnostic section. Replace Power Distribution Board (AACB5156)</p> 
<p><b>Dollar Bill Acceptor not functioning</b> Ensure Bill Acceptor is set to "Always Enable" <b>Important : Only 12 Volt DBA is to be installed.</b>  Model # AE 2454 U5E Part # A5AC9101</p>	<p>Check for power to Bill Acceptor. Dirt or debris in acceptor slot. Pinched, broken, or disconnected wiring.  Bill acceptor problem. Part # A5AC9101</p>	<p>Acceptor should cycle stacker at game power up. If not, check cable connections. Refer to "How to Clean Bill Acceptor" Or clean with bill reader cleaning card. (A5CC9000) Check wiring from bill acceptor to NewGen Board. (CE26008) Repair or replace wiring harness. Check connector on I/O Aux Board Make sure wires are secure in connectors. Refer to troubleshooting section of dollar bill acceptor manual included with this game or the diagnostics label of the back of the unit.</p>
<p><b>Meters do not work</b> Game meter will click at the start of the game. Ticket meter will click as tickets come out of game and notch is "seen" by dispenser.</p>	<p>Ensure correct number of tickets are being dispensed  Disconnected, loose or broken wires. Faulty counter.</p>	<p>Check ticket values in menu. Test Ticket Dispense in Diagnostic menu. Refer to Tickets not dispensing troubleshooting section. Check connections to I/O board. Cables # CE26012 and AACO1020 Replace counter. AACO1020.</p>

# TROUBLESHOOTING GUIDE





Problem	Probable Cause	Remedy
<p><b>Colored player console lighting not working</b></p> <p>LED's power the console edge first, then the plunger accent lights</p>	<p>If all colored cabinet lights are not functioning, check Light Board (AACB8001-LTM)</p> <p>If LED strip is out, check cable. Refer to "LED Light Board Wiring Diagram"</p> <p>Faulty LED</p> <p>Faulty Light Board</p>	<p>Check power to Light Board from Power Distribution Board. Cable # CE26017. Check USB cable to Light Board from motherboard. Cable # A5CORD58</p> <p>Check for proper connection from Light board to LED strips. Check continuity. Refer to "Sensor &amp; LED Wiring Diagram" (CE26010, CE26033, CE26032)</p> <p>Replace LED (CE26033, CE26032)</p> <p>Replace Light Board. (AACB8001-LTM)</p>
<p><b>White lights on side of wheel not working</b> (12 Volt LED's)</p>	<p>Faulty Cable</p> <p>Faulty LED</p>	<p>Side wheel white lights are 12 Volts DC, direct from Power Distribution Board to LED strips. Check continuity. (CE26004, CE26029) Refer to "Lighting Wiring Diagram"</p> <p>Replace LED strip CE26029</p>
<p><b>Colored lights on side of wheel not working</b> (12 Volt LED's)</p>	<p>Faulty Cable</p> <p>Faulty LED</p>	<p>Side wheel colored lights are 12 Volts DC, from Light Board which communicates to motherboard via USB cable. Check continuity. (CE22501, CE26030) Refer to "Lighting Wiring Diagram"</p> <p>Replace LED strip CE26030</p>
<p><b>White lights in marquee do not work</b> (12 Volt LED's)</p>	<p>Faulty Cable</p> <p>Faulty LED</p>	<p>Check for proper connection from Power Distribution Board to LED strips. Check continuity. (CE22504, CE22502) Refer to "Lighting Wiring Diagram"</p> <p>Replace LED strip CE22502</p>
<p><b>Colored lights in Marquee do not work</b> (12 Volt LED's)</p>	<p>Faulty Cable</p> <p>Faulty LED</p>	<p>Check for proper connection from Light Board to LED strips. Check continuity. (CE22505, CE22503) Refer to "Lighting Wiring Diagram"</p> <p>Replace LED strip CE22503</p>
<p><b>Eyeball Light in top of game does not work</b> (12 Volt LED's)</p>	<p>Faulty Cable</p> <p>Faulty LED</p>	<p>Check for proper connection from Light Board to LED strips. Check continuity. (CE22505, CE22506) Refer to "Lighting Wiring Diagram"</p> <p>Replace round LED board CE22506</p>
<p><b>No Sound</b></p> <p>Motherboard creates sound, Audio board amplifies it.</p>	<p>Volume set to zero in menu. Ensure "Mute" is set to OFF</p> <p>Disconnected, loose or broken wires.</p> <p>Faulty speaker.</p>	<p>Enter Attract &amp; Volume Menu and verify: Game Volume &amp; Attract Volume are not zero</p> <p>Check connections and reseat audio cable from motherboard to Audio Amplifier board to speakers. Cables # A5CORD21 from green socket on motherboard, A5CE2300, CE26001</p> <p>Ensure 12 volts at CE26018 cable from power supply.</p> <p>Unplug audio jack cable (A5CORD21) from motherboard, plug into MP3 player and see if music is amplified and comes out of speaker.</p> <p>If Yes - then motherboard is faulty.</p> <p>If No - then Audio Amplifier Board (AACB9600A) may be faulty.</p> <p>Replace speaker. AACE8811</p>

# TROUBLESHOOTING GUIDE

Problem	Probable Cause	Remedy
<p><b>Tickets do not dispense or Wrong amount dispensed.</b></p> <p>Check for the correct amount of tickets showing on Monitor</p>	<p>Tickets on monitor does <b>not</b> match tickets coming out of game.</p>	<p>Opto Sensor on ticket dispenser dirty.</p> <p>Faulty ticket dispenser.</p> <p>Notch on tickets cut too shallow.</p> <p>Faulty cable. Disconnected, loose or broken wires.</p> <p>Enter Diagnostic menu and test Dispenser</p> <p>Check dipswitches on I/O Aux Board</p> <p>Faulty I/O Aux Board</p>
	<p>Tickets on monitor do match tickets coming out of game.</p>	<p>Settings in Menu are incorrect.</p> <p>Home Sensor not working properly.</p> <p>Encoder Sensors not working properly.</p>
<p><b>Low Tickets message on monitor</b></p>	<p>Tickets are empty in ticket tray</p> <p>Faulty cable. Disconnected, loose or broken wires.</p> <p>Faulty low ticket switch.</p> <p>Faulty I/O Aux Board</p>	<p>Load tickets into tray. Ensure tickets hold down micro switch wire.</p> <p>Check connectors from low ticket switch to I/O Aux board. Check for continuity. (CE26013)</p> <p>Inspect switch and replace if needed. (AASW200)</p> <p>Check dipswitches on I/O Board, Replace I/O Aux Board if needed. AACB9605A-CBL</p>
<p><b>Light Board Issue</b></p> <p>Colorful lights around console and window are not flashing.</p> <div style="display: flex; align-items: center;"> <div style="margin-right: 10px;"> <p>Red and Yellow LEDs</p>  </div>  </div>	<p>Red power LED is normally on.</p> <p>Yellow and red LED are normally on.</p> <p>Faulty Light Board.</p>	<p>If it is off, then check 12 &amp; 5 Volts DC coming into board on cable CE26017 from Power Distribution Board.</p> <p>If solid on, then it is not communicating with the motherboard. Check A5CBL5900 USB cable. Swap cable with Wheel Control Board.</p> <p>Watch during attract mode and see if it flashes for a short time. Check A5CBL5900 USB cable. Swap cable with the Wheel Board.</p> <p>Replace Light Board if needed. Part # AACB8001-LTM</p>

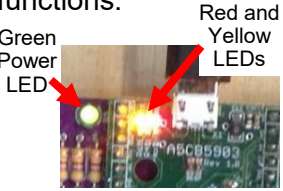

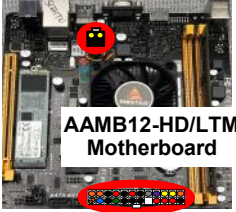
# TROUBLESHOOTING GUIDE

Problem	Probable Cause	Remedy	
<p><b>I/O Aux Board Issue</b> Game does not coin up, and has no other functions.</p> 	<p>Green power LED should be flashing.</p> <p>Red and Yellow LED's should be ON.</p> <p>Faulty I/O Aux Board</p>	<p>If it is off, then check 12 &amp; 5 Volts DC coming into board on cable CE26014 from Power Distribution Board.</p> <p>If solid on, then it is not communicating with the motherboard. Check A5CBL5900 USB cable. Swap cable with the light board.</p> <p>If they are off, it is not communicating with the motherboard. Check A5CBL5900 USB cable. Swap cable with the light board</p> <p>Replace I/O Aux Board if needed. Part # AACB9605A-MCC</p>	
<p><b>Wheel Board Issue</b> Solenoid will not engage, and sensor will not see wheel.</p> 	<p>Red power LED should be on.</p> <p>Yellow LED is normally off, and only flashes when communicating.</p> <p>Faulty Wheel Board</p>	<p>If it is off, then check 12 &amp; 5 Volts DC coming into board on cable CE26015 from Power Distribution Board.</p> <p>If solid on, then it is not communicating with the motherboard. Check A5CBL5900 USB cable. Swap cable with the light board.</p> <p>Watch while coining up and see if it flashes for a short time. Check A5CBL5900 USB cable. Swap cable with the light board</p> <p>Replace Wheel Board if needed. Part # AACB26000</p>	
<p><b>Monitor not working</b></p> <p>Power down, wait <b>5 minutes</b> and power up again.</p>	<p>Monitor shows "No Signal"</p>	<p>Monitor VGA cable unplugged from motherboard or back of monitor.</p> <p>Faulty or loose RAM on motherboard</p> <p>Large power connector unplugged on motherboard</p> <p>Small power connector unplugged on motherboard</p> <p>Faulty power supply - Refer to Power Supply diagnostic section</p> <p>Faulty motherboard - Replace faulty board. (AAMB12-HD/LTM)</p> 	
	<p>Monitor has nothing at all on power up.</p>	<p>Power cable unplugged from monitor</p> <p>Faulty monitor.</p>	<p>Ensure power is plugged into back of monitor, down to power strip.</p> <p>Replace monitor. (A5MO2221)</p>
	<p>Error on screen at power up.</p> <p>Re-Boot game to see if problem still exists.</p>	<p>Display shows "Kernel panic – unable to mount root"</p> <p>Display shows upside down motherboard Bios</p> 	<p>Faulty or loose RAM, faulty software, faulty motherboard</p> <p>No hard drive in motherboard.</p> <p>Replace with AAHD0032-LTM</p> 
<p><b>Home Sensor not working properly</b></p>	<p>Inspect assembly for physical obstruction</p> <p>Disconnected, loose or broken wires.</p> <p>Test Sensor.</p> <p>Faulty sensor.</p>	<p>The metal tab on the left side of the wheel (from the back) must pass over sensor at a distance of 1/2" Too close is bad, too far away is bad. Ensure the metal tab is clean and reflective.</p> <p>Check connections from opto sensor to I/O board. Refer to wiring diagram. (Cable # CE26007)</p> <p>Enter Diagnostic Menu, Wheelboard area to see if game recognizes sensor. Screen will flash "Home Sensor" when sensor is seen. Once per revolution.</p> <p>Replace sensor if needed. AACB4403</p>	

# TROUBLESHOOTING GUIDE

Problem	Probable Cause	Remedy
<b>Encoder Sensors not working properly</b>	Inspect assembly for physical obstruction  Disconnected, loose or broken wires.  Test Sensor.  Faulty sensor.	There are 2 identical sensor boards in the arrow housing. 2 sets of optos watch the notches on the edge of the wheel. These sensors keep track of how many notches pass by to determine wheel position. The home sensor will reset this count.  Check connections from opto sensors to I/O board. Refer to wiring diagram. (Cable # CE26019, CE26011) The cable with the white wire must attach to the front sensor.  Enter Diagnostic Menu, Wheelboard Section to see if game recognizes sensor. Will flash “Notch Sensor” when sensor sees a notch. Screen will also show the ticket value on the screen as the wheel is turned downward.  Replace arrow sensor if needed. Part # AAPO26000
<b>Pushing plunger does not spin wheel</b>	Inspect assembly for physical obstruction  Solenoid is not engaging.	The solenoid assembly should pivot as handle is pushed down. The wheel will only turn if the solenoid is engaged. Refer to “Pivot Assembly Exploded View” to identify worn parts to replace.  Refer to “Solenoid does not activate”
<b>Solenoid does not activate</b>	Inspect assembly for physical obstruction  Disconnected, loose or broken wires.  Test solenoid.  Faulty solenoid.  Wheel Board communication: Red and yellow power LED’s should be on.	Refer to “How to Remove Wheel” to access the solenoid assembly Ensure assembly is loose and moves freely.  Check connections from solenoid to Wheel Board. Refer to wiring diagram. (Cable # CE26000)  Enter Diagnostic Menu and select “Engage Wheel”. The solenoid should now receive 12 Volts DC.  Replace solenoid assembly if needed. AASO26001  If it is off, then check 12 & 5 Volts DC coming into board on cable CE26015 from Power Distribution Board.  If solid on, then it is not communicating with the motherboard. Check A5CBL5900 USB cable. Swap cable with the light board.  Replace Wheel Board if needed. Part # AACB26000
<b>Solenoid is on all the time</b>	Inspect assembly for physical obstruction  Check for 12 Volts DC on solenoid cable CE26000	Refer to “How to Remove Wheel” to access the solenoid assembly Ensure assembly is loose and moves freely.  If 12 Volts DC is always present, the Wheel Board AACB26000 is faulty and will need to be replaced.  If no 12 Volts DC and solenoid is still engaged, the solenoid assembly AASO26001 is faulty and will need to be replaced.
<b>Wheel values are a bit off target</b>	Ensure the wheel is not rocking backward as it comes to a stop.  Arrow sensor needs adjustment	The wheel brake should be tighten to ensure the wheel does not rock backward over a notch when it comes to a stop. Enter Diagnostic Menu, Wheel Debug, Select Engage Wheel and spin the wheel fast. Refer to “How to Adjust Brake Tension”  Refer to “How to Adjust Arrow Sensor”

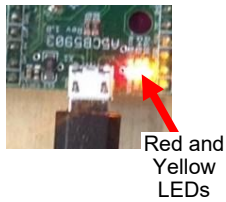

# TROUBLESHOOTING GUIDE

Problem	Probable Cause	Remedy
<p><b>Game not coining up</b></p> <p>If installing a card swipe reader, refer to Card Swipe System Installation page in front of manual.</p>	<p>Check for I/O board USB cable communication.</p> <p>Ensure game makes sound when coin switch is triggered.</p> <p>Game set to large amount of credits per game.</p>	<p>Refer to "I/O Aux Board Issue" diagnostic Section.</p> <p>Check coin switches—both should be wired normally open. If one switch is "closed" the other will not work either. Check wiring to I/O Board. (AACBL4A-DOORA, CE26013)</p> <p>Check 12 Volt power in from Power Dist Board.</p> <p>Check Game Setup Menu. Ensure Credits in Payout Settings menu is set. Default = 1</p>
<p><b>Menu Buttons do not work</b></p>	<p>Swap connectors at the 2 buttons.</p> <p>Pinched, broken, or disconnected wiring</p> <p>Main board faulty.</p>	<p>Replace button if problem stays with button.(AAPB2700)</p> <p>Inspect crimp to ensure good connection.</p> <p>Check connections from menu buttons to I/O board.</p> <p>Check continuity on wires. (AAPB2700, CE26012)</p> <p>Replace I/O Aux Board. (AACB9605A-CBL)</p>

## I/O AUX BOARD PINOUT



- = +12 VDC
- = Ground
- = +5 VDC
- = Output
- = Input

**Outputs:**

- Q1 (PD1) Game counter
- Q2 (PD0) Tickets counter
- Q3 (PD6) Coin Lockout
- PE6 Ticket Enable

**Inputs:**

- PD4 Menu Button
- PC6 Select Button
- PD7 Ticket Notch
- PB4 Coin In
- PB5 DBA In
- D15 (A1) Low Ticket Switch Input

# MB13 MOTHERBOARD DIFFERENCES

Little Ticket Monster games originally had MB12 motherboards. During March, 2023 - the MB12 motherboard became obsolete and was changed to an MB13.

**Difference # 1:** The additional power supply connection is 8 pins instead of 4 pins.

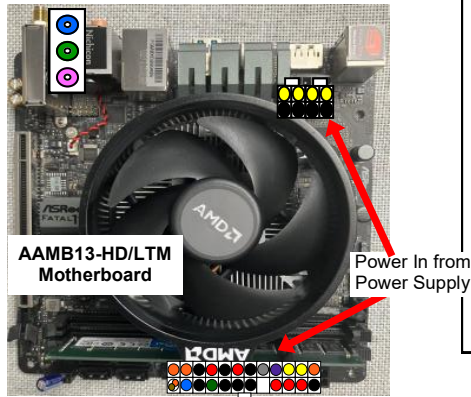

The older MB12 has one 4 pin connector pushed into motherboard, and one 4 pin connector loose.

The MB13 uses both of these 4 pins pushed together to make one 8 pin connector.

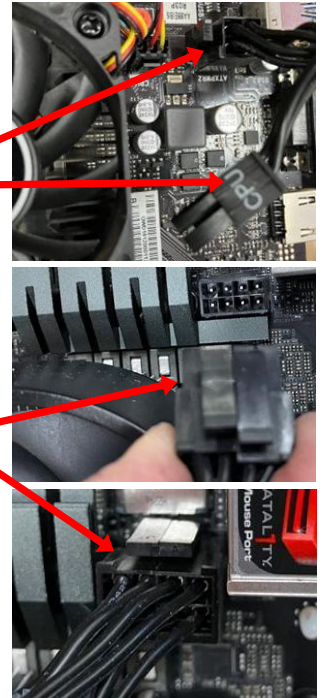

**Difference # 2:** The power on capacitor is located in a different location on the plug and it is now part # AACA1320-10



**Difference # 3:** The M.2 software drive ( Part # AAHD0032-LTM) is now located on the bottom, underneath the motherboard.

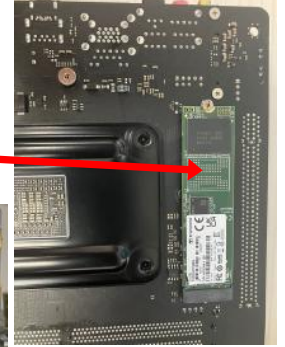

**Difference # 4:** There are more jacks on the motherboard, but the sound jack still plugs into the green socket.

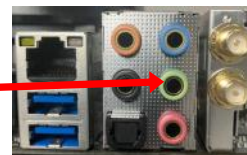

# BILL ACCEPTOR DIAGNOSTICS

**Note:** There are many different models and brands of Bill Acceptors that are used on redemption games. Your Bill Acceptor may differ from the unit shown. Standard DBA is MEI # AE2454-U5E Part # A5AC9101 Only use 12 Volt DC Bill Acceptor

Determine if Bill Acceptor has power:  
Turn game ON—The bill acceptor should make noise as stacker cycles and green lights on outside bezel should flash.

If NO power:

Use meter to measure 12 VDC voltage at cable going into Bill Acceptor from front I/O Aux Board

If power is OK:

Clean Bill Acceptor path to make sure there is nothing jamming unit.

Check dipswitch settings on side of acceptor.

**Make sure switch # 8 is OFF for Always Enable**



## ERROR CODES

Count the number of flashes on front bezel of Bill Acceptor and follow on Bill Acceptor chart for repair instructions.

# POWER SUPPLY DIAGNOSTICS

- 1.) Verify AC power to game. Check power strip in front door. The rocker switch should be illuminated.
- 2.) Check connection to power supply.
- 3.) Ensure Power Supply switch is set to 115V (or 230V)  
(Some model power supplies may not have this)
- 4.) Ensure Power switch is on.
- 5.) Ensure fan is turning.

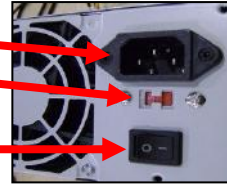

- If power supply fan is turning and there is no 12 Volt out:  
Check power supply cables to the Power Distribution Board.

This board takes the power in, and directs it to the different 12 volt loads.

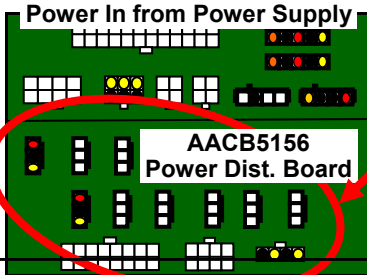

- Replace power supply if this board is not receiving 12 volts. (A5PS1021)
- Unplug all power out connectors from the right side of the Power Distribution Board. Turn on game and if it boots correctly, plug one cable in at a time until the issue is found.
- If power supply fan is not turning, then continue to "Verify Power to Motherboard"

## Verify Power to Motherboard

The motherboard will turn on power supply.

If your game has no 12 volts, it may be the motherboard not turning on.

Also - there may be a 12 volt short somewhere in cabinet that is not allowing the power supply to turn on.

### AAMB12-HD/LTM

Make sure the 4 pin power connector is plugged in.  
(Black, Black, Yellow, Yellow)  
As well as 24 pin power in connector.

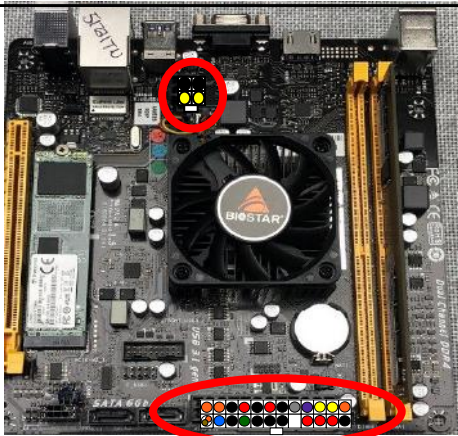

### AAMB13-HD/LTM

Make sure the 8 pin power connector is plugged in.  
(2 of 4 pin connectors together)  
As well as 24 pin power in connector.



OR

## Minimize load on power supply and isolate short

Unplug the power supply cables going to the Power Distribution Board.

This will leave the power supply, motherboard, and monitor left plugged in together.

If power supply, motherboard, and monitor now turn on:

Plug in the Power Distribution Board to power supply, but unplug all of the outputs from the board.

Turn on game and verify the 12 volts is good.

Then plug in one component at a time to power supply to locate short.

If power supply still does not power on:

Replace power supply (A5PS1021), or motherboard. (AAMB13-HD/LTM)

# HOW TO CHANGE SOFTWARE ON MB12

## New Software Installation:

The hard drive contains all the information about the game: Credits per play, ticket pattern, etc. Be sure to check this information after finishing installing new software.

Turn off game by flipping the power switch on the power strip.

Locate hard drive on motherboard.

Remove this screw with a small #1 Phillips screwdriver.

There is a small white plastic spacer under the screw.

Leave this on the board, the M.2 drive will rest on top of this spacer.

Remove the old software.

Slide the M.2 new software drive into the slot on the motherboard as shown.

Notice the white spacer is still on the motherboard.

Using a small # 1 screwdriver, re-insert the screw into the motherboard to secure the software.

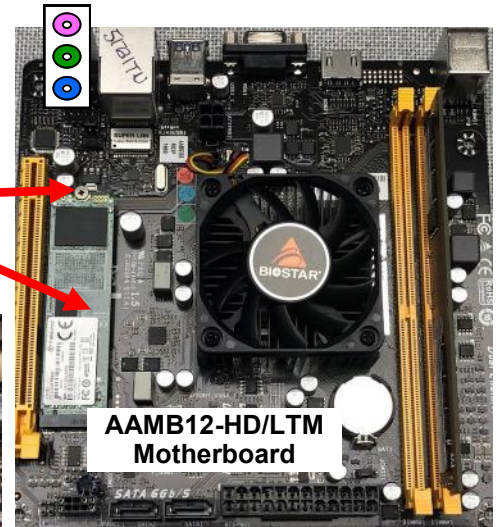

# HOW TO CHANGE SOFTWARE ON MB13

Little Ticket Monster games can use 2 different motherboards.

The MB12 was the original motherboard which became obsolete and was changed to an MB13 during March 2023.

This is the MB13 motherboard

These instructions will detail how to change software on the MB13.

This is the M.2 Drive as a hard drive with software.



This M.2 Drive is located on the bottom, underneath the motherboard.

Remove this screw with a small #1 Phillips screwdriver.

Slide the M.2 new software drive into the slot.

Using a small # 1 screwdriver, re-insert the screw into the motherboard to secure the new software.

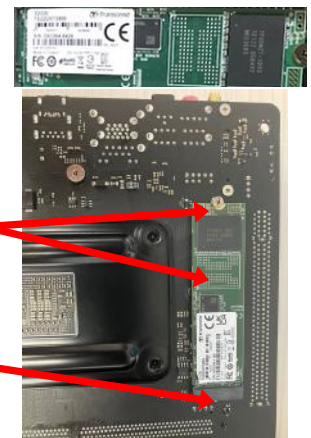

# HOW TO OPEN THE FRONT PLEXI

The front plexi can be removed from the game to allow monthly cleaning.

## Instructions:

Remove the back door of the game and set aside.

Open the front door and locate the 2 latches securing the front plexi in place.

The front plexi will now slide up (like a roll top desk) and can be removed from the back of the game.

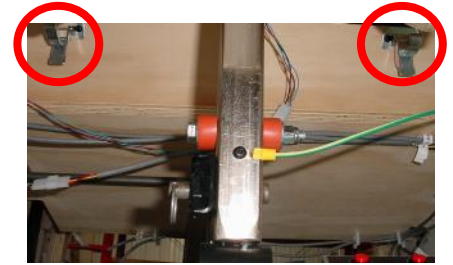

# HOW TO REMOVE ARROW SENSOR

The arrow sensor must be removed to replace, or when removing the wheel to replace the solenoid.

## Tools Needed:

Phillips Screwdriver # 2 Square bit

## Instructions:

The front plexi must be open or removed to access the arrow sensor. Refer to "How to Open the Front Plexi" to remove plexi.

Once plexi is removed, remove the 2 screws attaching blocking plate to the white plastic using a # 2 square bit screwdriver.

Loosen, but do not remove, the 1 bolt using a Phillips screwdriver. Remove the "Win" arrow metal plate by sliding to the left.

Remove the 2 Phillips screws from the top rail.

The arrow sensor assembly can now be unplugged and removed from the cabinet.

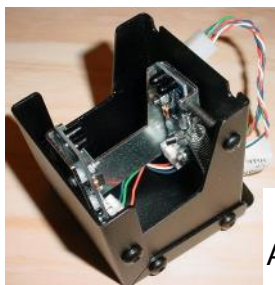

AAPO26000  
Arrow Sensor Assy

# HOW TO ADJUST ARROW SENSOR

The wheel sensor “sees” the notches on the right side of the wheel. As the game is played, the wheel spins downward and the ticket value changes as the point of the arrow crosses the dividing line. If the wheel value changes too early or too late, the sensor must be adjusted.

## Tools Needed:

Phillips Screwdriver

## Instructions:

The front plexi must be open, refer to “How to Open the Front Plexi”.

Use a Phillips screwdriver to turn the screw on the bottom of the arrow assembly.

Clockwise will raise the sensor.

Counter-clockwise will lower the sensor.

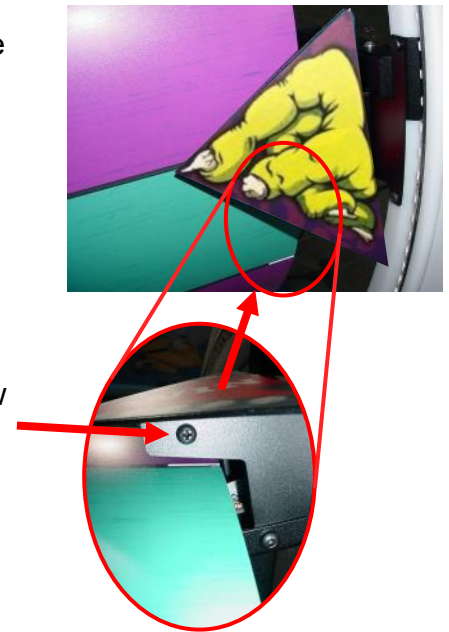

# HOW TO ADJUST BRAKE TENSION

The wheel brake is spring tensioned pad that pushes against the wheel to slow and stop the wheel after a “good spin speed” has been reached.

Too tight of brake tension will stop the wheel quickly and may allow a skilled player to master the technique and achieve more bonus wins.

Too loose of brake tension may allow the wheel to rock backwards as it comes to a stop. If it rocks backward over a notch, the tickets won will be incorrect.

## Instructions:

Remove the back door of the game and set aside.

Use a needle nose pliers to loosen the nuts on the threaded eye hook.

Adjust threaded eye hook up - to increase tension on wheel brake.

Adjust threaded eye hook down - to decrease tension on wheel brake.

To test brake tension: Enter Diagnostic Menu, Wheel Debug Menu.

Enable Engage Wheel and push the handle to spin the wheel fast.

The screen will show “tighten Brake”, “Loosen Brake”, or “Brake OK”





# HOW TO REMOVE HOME SENSOR

The home sensor is located on the left side of the wheel, when looking from the back of the game.

**Tools needed:** 7/16" Wrench

**Instructions:**

Unlock the back door using a H95 key.

Remove the back door by using both handles to lift upwards and pull out.

To allow more room to remove sensor, first remove the top nut of wood side brace using a 7/16" wrench, and remove the bolt.

Swing the wood side brace down and out of the way.



The wood block is designed to slide off this top post once the bottom bolt is removed:

Remove the bolt, lock washer, and washer from the lower end of the wood block using a 7/16" wrench.

The wood block with the sensor attached will now slide off the top post.

The sensor can now be cleaned or replaced if needed by removing the 2 Phillips screws. Sensor is part # AACB4403

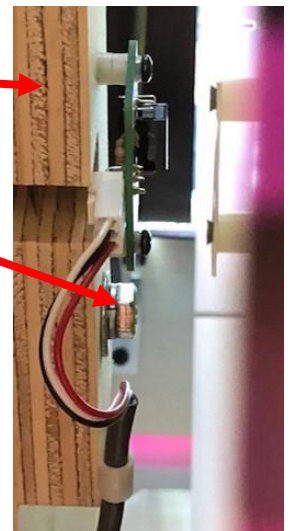
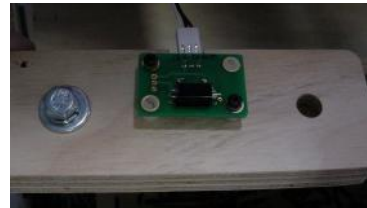

# HOW TO REPLACE MONITOR

The 22" monitor can be removed from the back top of the game

**Tools Needed:**

1 step ladder (4-6 foot) # 2 Square bit  
Phillips Screwdriver

**Instructions:**

Carefully climb to the top rear of cabinet.

Remove the 4 bolts using a Phillips screwdriver.

Remove the 4 screws using a # 2 square bit.

Disconnect VGA from the top of the monitor.

Unplug power cord from the top of the monitor.

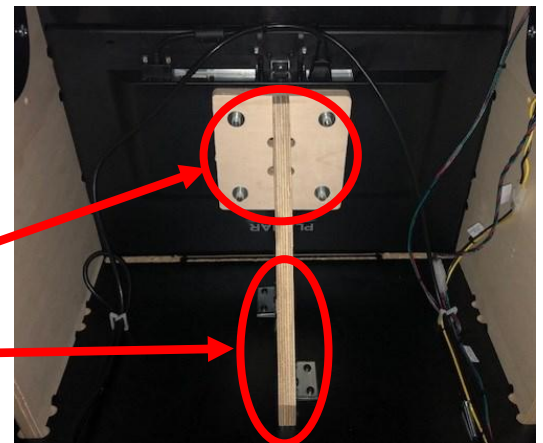

The monitor can now be removed and replaced. Monitor part # A5MO2221

Note: The monitor is purposely installed in the cabinet upside down for optimal visibility.

# HOW TO REPLACE SOLENOID

The wheel must be swung outward to access and replace the solenoid assembly.

## Tools Needed:

Phillips Screwdriver      # 2 Square bit      7/16" wrench      1/2" wrench

## Instructions:

The arrow sensor must be removed so it does not **damage** the wheel, refer to "How to Remove Arrow Sensor"

Remove the 2 top nuts, lock washers, and washers of wood side braces using a 7/16" wrench, and remove the bolts.

Swing the 2 wood side braces down.

The wheel will tilt down and rest on these braces.

Remove the top cable clamp using a # 2 square bit screwdriver.

Remove the bottom cable clamp using a # 2 square bit screwdriver.

Remove the cotter pin (part # A5PICZ001) and slide the wheel link off of the pivot arm.

Unplug the 2 pin molex connect for solenoid power.

Remove the 2 top nuts, lock washers, and washers of wheel cradle frame using a 1/2" wrench, and remove the bolts.



# HOW TO REPLACE SOLENOID

Slowly pivot the wheel cradle downward to rest on wood side braces.

Before we disassemble the center wheel hub to remove the solenoid assembly, the wheel itself needs to be supported. This will prevent the wheel from twisting and causing **damage**.

There are 2 wood blocks that are shipped with the game in the coin box, with a bolt, lock washer, and washer.



A5BOHH060



A5WASI020

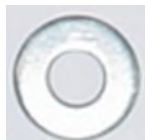

A5WAFL060

Slide the long narrow piece into the slot of the other piece to create a shelf.



Install the bolt, lock washer, and washer using a 7/16" wrench as shown.

Ensure the wheel is supported before continuing.

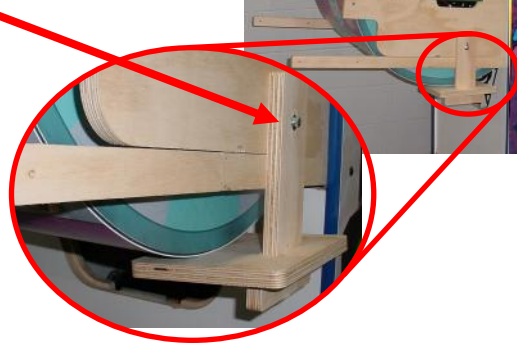

Note: When re-installing the wheel link to the pivot arm, bring the arm up toward the rear of the game and attach.

This will make sure the solenoid is swung to the correct position.

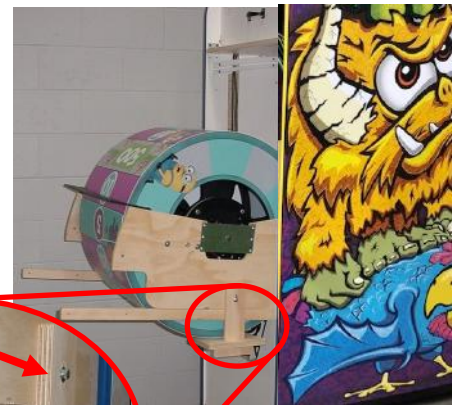
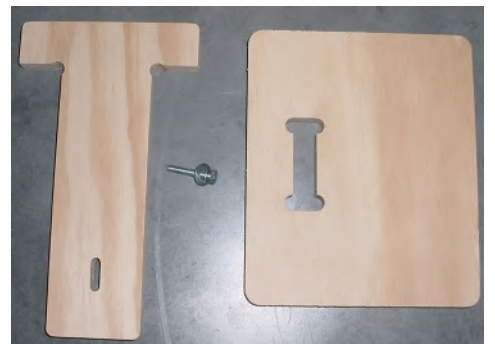
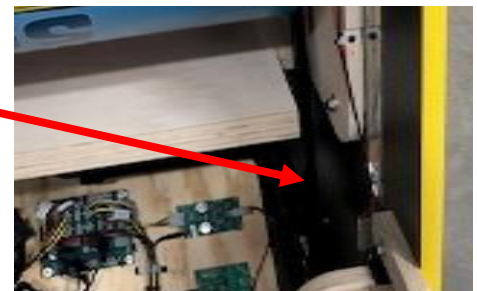

# HOW TO REPLACE SOLENOID

After wheel is supported, remove the retaining ring and side metal arm from solenoid assembly.

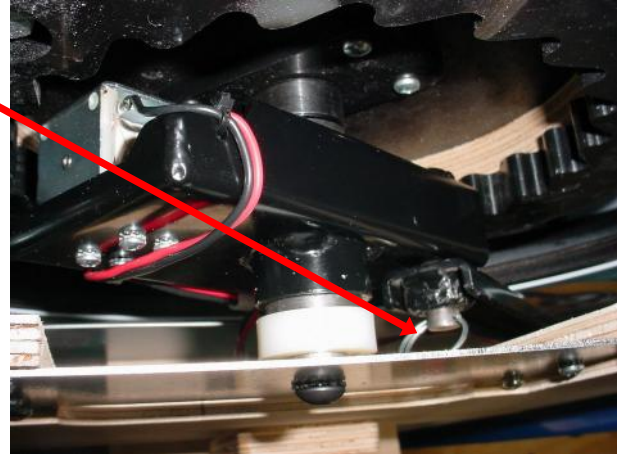

Remove the 6 screws using a Phillips screwdriver.

Remove the center bolt and star washer using a 7/32" Allen wrench.

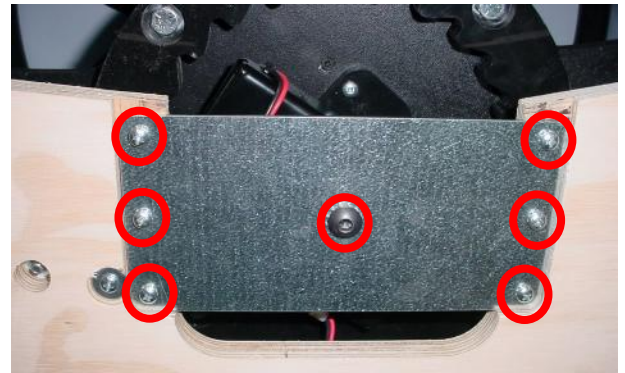

Remove the metal plate, and remove the white plastic spacer from the wheel shaft.

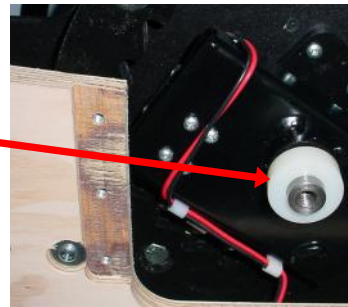

The solenoid assembly (AASO4010) can now be removed from the wheel shaft.

Upon installation of the new solenoid assembly, make sure the cable is routed through the metal retaining clip. This will keep the cable away from the wheel as the handle moves up and down.

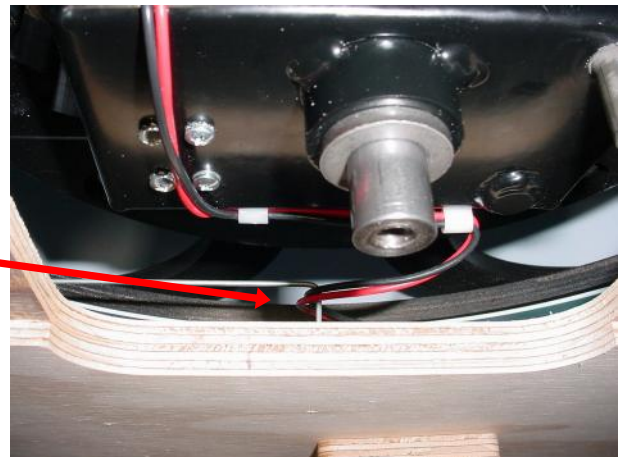

# PIVOT ASSEMBLY EXPLODED VIEW



## Lil Ticket Monster Pivot Assembly Exploded View Diagram

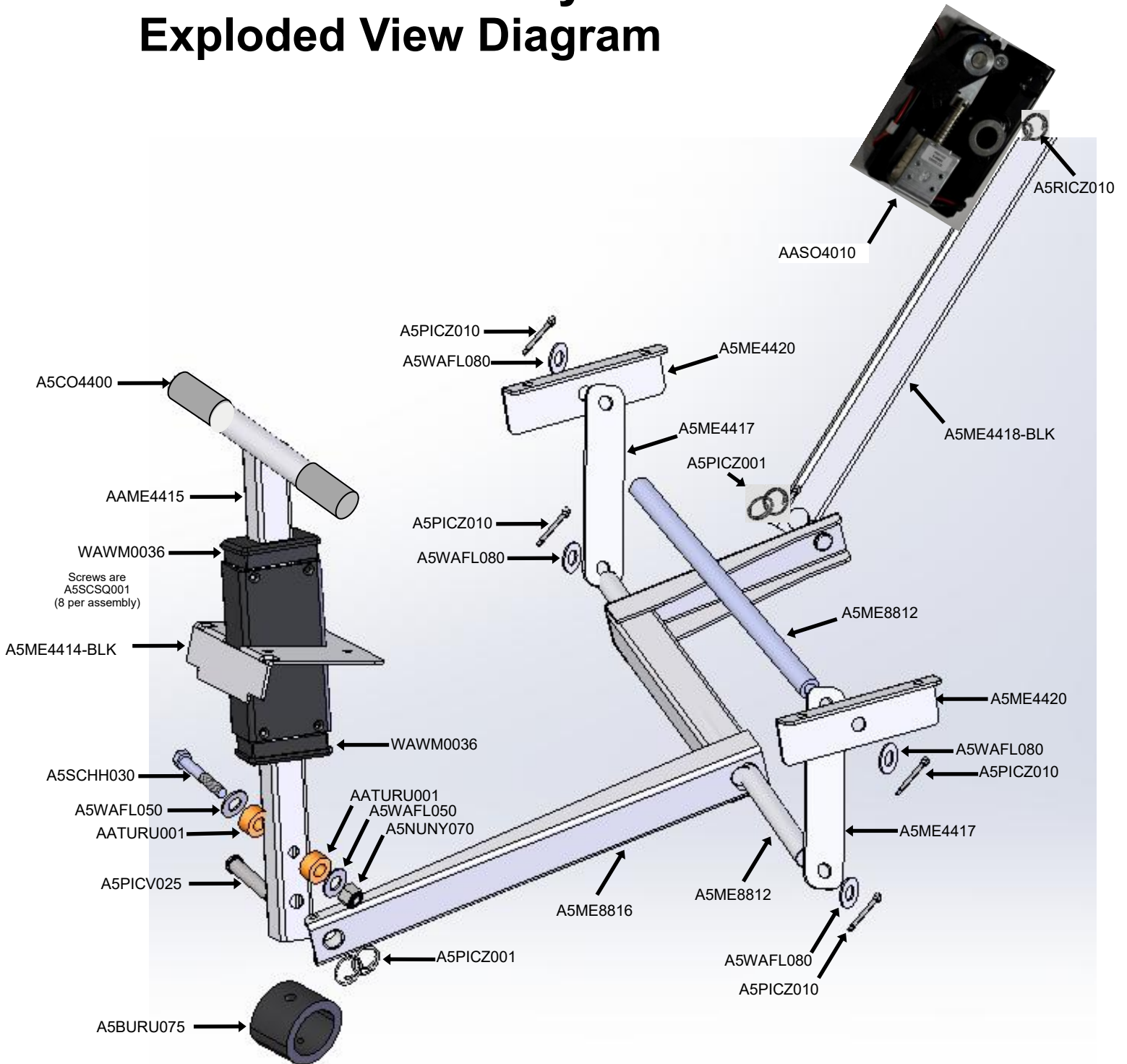

# DECAL DIAGRAM



**PARTS NOT VISIBLE**

- A5DE22503 Left Bottom Side Cabinet Decal
- A5DE22505 Left Cabinet Rail Decal
- A5DE22508 Left Wheel Side Decal
- A5DE22522 Left Marquee Arm Decal

# PARTS LIST

PART #	DESCRIPTION	PART #	DESCRIPTION
A5BK9999	Bracket, Power Supply Mounting	A5DE22511	Decal, Plunger Wrap
A5BRMP010	2 1/2" X 3/4"W Flat Mending Plate	A5DE22512	Printed Plexi, Plunger Base
A5BRMP020	5 1/8" X 3/4"W	A5DE22513	Printed Plexi, Console
A5BURU075	Bumper, Black Rubber,2 1/4x2 5/8	A5DE22514	Decal, Cabinet Bottom Front
A5CB8020	Cash Box	A5DE22515	Decal, Cabinet Front Door
A5CL1004	Clamp, Versa Latch, 2 Per Game	A5DE22516	Plexi Rolux Ticket Piece
A5CO4400	Grip Cover for Handle, 2 Per Game	A5DE22522	Decal, Marquee Arm, Left
A5GU4400	Guard, Bent Wire	A5DE22523	Decal, Marquee Arm, Right
A5LK2001	Lock, Cash Box, A05/E00 Key Code	WACA26056	Side Window, Acrylic, 2 Per Game
A5LK5002	Lock, 7/8", H95 Key Code, 2 Per Game	WACA26030	Front Window (Plexi Only)
A5PL0010	Plug, Fits 1" Tube OD, 2 Per Game	WAWM0036	Handle Guide, Black Plastic
A5RO8800	Rod, 18.092 Inch, 8 Per Game	W5TM2300	Orange T Molding (14.5 Feet Per Game)
A5SLSX001	Shaft Collar, 3/4"Bore, 2 Per Game	W5TM4006	Yellow T Molding (14.5 Feet (173") Per Game)
A5SP5021	Spring, Compression	AAVF22500	Vacform Eyeball with Decal
A5SREX050	Spring,6",3/8"Od,.041" Wire	A5ME2034	Ticket Tray
AASW200	Switch, Score/Low Ticket Switch	A5ME26000	Metal, Arrow Wire Cover
AAWH26000	Bottom Roller Wheels, 2 Per Game	A5ME26001	Metal, Caster Plate, 2 Per Game
AABK1013	Bracket, Pushbutton/Counters	A5ME26005	Metal, Pointer Front
AACO1020	Ticket & Game Counter Assy	A5ME26006	Metal, Side Guards, 2 Per Game
AAHA26000	Handle Assembly With Grips	A5ME26007	Metal, Side Window Rail, 2 Per Game
AAPO26000	Sensor Assembly For Pointer	A5ME26008	Metal, Sliding Window Rail
AASO26001	Solenoid Assembly With Bracket	A5ME26009	Metal, Sliding Window Handle
AATURU001	Orange Rubber Tubing, 2 Per Game	A5ME26010	Metal, Wheel Mounting Plate
W5HG1025	Hinge,16", Double Bend	A5ME26011	Metal, Wheel Shaft
W5HG1065	Hinge, 5-75, Single Bend	A5ME26012	Metal, Wheel Support Bracket
W5KE5000	Keeper, Lock, 2 Per Game	A5ME26013	Metal, Window Brace, 2 Per Game
A5DE0042	Decal, Menu/Volume Decal	A5ME4167	Metal, Solenoid Link
A5DE0044	Decal, Remove Arrow Before Wheel	A5ME4182	Metal, Cashbox Guide
A5DE22500	Printed Plexi, Ticket Marquee	A5ME4414- BLK	Metal, Handle Guide Assy
A5DE22501	Decal, Top Monster Wrap	A5ME4417	Metal, Pivot Link, 2 Per Game
A5DE22502	Decal, Eyeball	A5ME4418-BLK	Metal, Wheel Link
A5DE22503	Decal, Cabinet Side Bottom, Left	A5ME4420	Metal, Pivot Link Bracket, 2 Per Game
A5DE22504	Decal, Cabinet Side Bottom, Right	A5ME4429	Metal, Bracket, Solenoid
A5DE22505	Decal, Cabinet Rail, Left	A5ME4430	Metal, Slip Clutch Bracket
A5DE22506	Decal, Cabinet Rail, Right	A5ME8812	Metal, Handle Rod, 2 Per Game
A5DE22507-1	Decal, Wheel Wrap, Pattern # 1	A5ME8816	Metal, Rocker Arm
A5DE22507-2	Decal, Wheel Wrap, Pattern # 2	A5PL4200	Mounting Plate For 12 Volt DC Bill Acceptor
A5DE22507-3	Decal, Wheel Wrap, Default Pattern #3	A5PL8900	DBA Blanking Plate For 12 VDC Bill Acceptor
A5DE22507-4	Decal, Wheel Wrap, Pattern # 4	A5PL9995	Blanking Plate for Coin Door
AADE22510	Ticket Cover Up Wheel Decal Set	A5PL9998	Blanking Plate for Ticket Dispenser
A5DE22508	Decal, Wheel Side, Left	A5CBL5900	Cable, USB, Male A -Male Micro, 3 Per Game
A5DE22509	Decal, Wheel Side, Right	A5CE2300	Cable, Audio Isolator
A5DE22510	Decal, Pointer Arrow	A5CORD1	Cord, Power,10'

# PARTS LIST

PART #	DESCRIPTION	PART #	DESCRIPTION
A5CORD20	Cable, 10', SVGA	AACE26019	Arrow Sensors
A5CORD21	Cord, 3', 3.5mm Male to Male, Audio Cable	AACE26020	Ground Stud to Plunger
A5CORD5	Cord, AC Computer Cord, 6.5'	AACE26021	Ground Stud to Door Hinge
A5CORD5000	Cord, Power Strip Adapter, 1ft. 2 Per Game	AACE26023	Ground Stud to Ticket Dispenser
AACE1710	Cable, 4" Door Ground Cable, 2 Per Game	AACE26029	Wheel Lights, 2 Per Game
AACE1715	Cable, Door Ground Cable	AACE26030	Window Outer Frame Light, 2 Per Game
AACE22500	Line Filter Cord to Power Strip	AACE26032	Plunger Accent Light
AACE22501	Console Addressable Power	AACE26033	Outside Console Light
AACE22502	Middle Marquee Light Power Jumper	AACE8811A	Cable Assy, Speaker
AACE22503	Outside Marquee/Eyeball Power Jumper	AAPB2700	Push Button, 2 Per Game
AACE22504	Middle Marquee Light Power		
AACE22505	Outside Marquee/Eye Power	AACBL4A-	Door Cable
AACE22506	Eyeball Light Board	A5FI9010	Filter, Inline
AACE26000	Solenoid Power from CB26000	A5AC9101	Bill Acceptor, 12 Volt DC
AACE26001	Speaker Wire from CB9600	A5MO2221	Monitor, 22"
AACE26004	White Console Lights Power	A5OU5000	Outlet Strip
AACE26007	Power to Home Sensor from CB26000	A5PS1021	Power Supply, 450 Watt
AACE26008	DBA Cable from CB9605 Board	A5TD1	Ticket Dispenser
AACE26010	Console RGB Light Power from CB8001	AACB15001	PCB Assy, Bleed Resistor Board
AACE26011	CB26000 Encoder Sensor to Arrow	AACB26000	PCB, Wheel Control, Minions
AACE26012	CB9605 Board to Menu/Counters Bracket	AACB4403	Reflector Sensor
AACE26013	CB9605 Board to Coin Door and Tickets	AACB5156	Power Distribution Board
AACE26014	Power Distribution Board to CB9605	AACB8001-LTM	Light Driver Board
AACE26015	Power Distribution Board to CB26000	AACB9600A	Audio Amplifier Board
AACE26017	Power Distribution to CB8001 Power	AACB9605-CBL	Door Interface Board
AACE26018	Power Distribution to CB9600 Power	AAHD0032-LTM	M2 SATA, Lil Ticket Monster
		AAMB12-HD/LTM	Motherboard, Lil Ticket Monster W/Sata



# PARTS PICTURES



A5BK9999 A5BRMP010 A5BRMP020 A5BURU075 A5CB8020 A5CL1004 A5CO4400 A5GU4400



A5LK2001 A5LK5002 A5PL0010 A5RO8800 A5SLSX001 A5SP5021 A5SREX050 A5SW220



AAWH26000 AABK1013 AACO1020 AAHA26000 AAPO26000 AASO26001 AATURU001 W5HG1025



W5HG1065 W5KE5000 A5DE0042 A5DE0044 A5DE22500 A5DE22501 A5DE22502



A5DE22503 A5DE22504 A5DE22505 A5DE22506 AADE22510 A5DE22507-1 A5DE22507-2



A5DE22507-3 A5DE22507-4 A5DE22508 A5DE22509 A5DE22510 A5DE22511 A5DE22512



A5DE22513 A5DE22514 A5DE22515 A5DE22516 A5DE22522 A5DE22523

# PARTS PICTURES

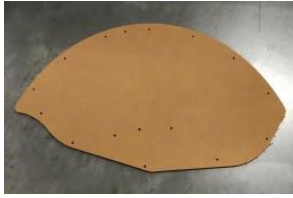

WACA26056



WACA26030



WAWM0036



W5TM2300



W5TM4006



AAVF22500

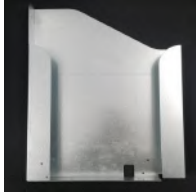

A5ME2034



A5ME26000



A5ME26001



A5ME26005



A5ME26006



A5ME26007



A5ME26008



A5ME26009



A5ME26010



A5ME26011



A5ME26012



A5ME26013



A5ME4167

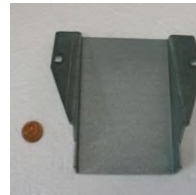

A5ME4182



A5ME4414-BLK



AAME4417



A5ME4418-BLK



A5ME4420



A5ME4429



A5ME4430



A5ME8812



A5ME8816



A5PL4200

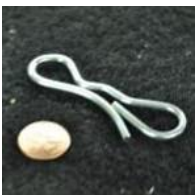

A5PICZ001



A5PICZ010



A5PL8900



A5PL9998



A5CBL5900



A5CE2300



A5CORD1



A5CORD20



A5CORD21



A5CORD5



A5CORD5000



AAACE1710



AAACE1715



AAACE22500



AAACE22501



AAACE22502



AAACE22503



AAACE22504



AAACE22505



AAACE22506



AAACE26000



AAACE26001

# PARTS PICTURES



**AACE26004**



**AACE26007**



**AACE26008**



**AACE26010**



**AACE26011**



**AACE26012**



**AACE26013**



**AACE26014**



**AACE26015**



**AACE26017**



**AACE26018**



**AACE26019**



**AACE26020**



**AACE26021**



**AACE26023**



**AACE26029**



**AACE26030**



**AACE26032**



**AACE26033**



**AACE8811**



**AAPB2700**



**AACBL4A-DOORA**



**A5FI9010**



**A5AC9101**



**A5MO2221**



**A5OU5000**



**A5PS1021**



**A5TD1**



**AACB15001**

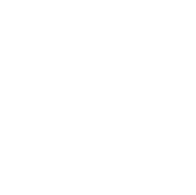

**AACB26000**

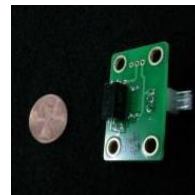

**AACB4403**



**AACB5156**

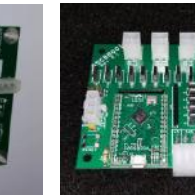

**AACB8001-LTM**

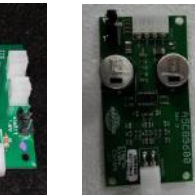

**AACB9600A**



**AACB9605-CBL**



**AAHD0032-LTM**



**AAMB12-HD/LTM**



**AAMB13-HD/LTM**



# TECHNICAL SUPPORT

Excellent customer service is very important to Bay Tek Entertainment! We know that keeping your games in great operating condition is important to your business. When you need us, we are here to help. You can call us for free technical assistance, and you can count on us to have parts on-hand to support your game. When you do need us, it's important that you know what to expect.  
We offer options that fit your needs.

## **Electronics / Circuit Boards:**

**Spare Parts** – Take matters into your own hands and purchase new spare Circuit Boards for your Bay Tek games. Many of our games share the same main-board electronics. This means you can buy one set of spare electronics to support many of your Bay Tek games. Spare boards allow you to get your game up and running the quickest and provide you a valuable troubleshooting option. Call our technicians to get recommendations for what you should keep on hand for spare parts!

## **Technical Support:**

“You” are the best tool for troubleshooting! Your abilities to understand the game and your skills to repair the game are invaluable to us! If you need help, you know you can call us. It's not easy to diagnose a game remotely by phone, but our technicians do a great job. They'll need your help to perform some troubleshooting steps and convey to them exactly what's happening with your game.

## **Returns & Credits:**

Sometimes the issue isn't what it seemed to be. If you need to return a circuit board, just give us a call to get Return Authorization. You will be credited for the cost of the board and charged only the bench fee for our processing and retesting that board.

*Note: Bench fees apply regardless of whether the repair was your choice or a recommendation from a Bay Tek Entertainment technician.*

*It's a small price to pay for troubleshooting the issues with your game.*

**[You can count on our Technical Support Team for service and support!](#)**

# WARRANTY OPTIONS

Bay Tek Entertainment warrants to the original purchaser that the game will be free of defects in workmanship and materials for a period of 12 months from the date of shipping

Bay Tek Entertainment will, without charge, repair or replace at it's option defective product or component parts upon notification to the parts/service department.

New, purchased parts have a 30 day warranty.

Any labor expended is not included in this warranty.

Warranty replacement part(s) will be shipped immediately via ground service, along with a Return Material Authorization (RMA) number for the return of defective part(s). Defective part(s) must be shipped back to Bay Tek Entertainment unless otherwise instructed.

***This warranty does not apply in the event of any misuse or abuse to the product, or as a result of any unauthorized repairs or alterations. The warranty does not apply if the serial number decal is altered, defaced, or removed from it's original position.***

Should you need your game serviced, determine the serial number from the decal on the back of the game cabinet or main board, and call **920.822.3951 Ext. 1102**

or e-mail to: [baytek.service@thevillage.bz](mailto:baytek.service@thevillage.bz)