

The JEWELRY *Box*™



OWNERS AND SERVICE MANUAL INNOVATIVE CONCEPTS IN ENTERTAINMENT INC.

10123 MAIN STREET, CLARENCE, NY 14031

SERVICE: 1-716-759-0360

FAX: 1-716-759-0884

E-MAIL: service@icegame.com

WEBSITE: www.icegame.com

TABLE OF CONTENTS

INTRODUCTION.....	PAGE 3
• GAME FEATURES	
• GAME PLAY	
SET-UP / TESTING / MAINTENANCE.....	PAGE 4 –12
• SAFETY PRECAUTIONS	
• GAME SET-UP	
• ASSEMBLY	
• TESTING	
• CLEANING	
PROGRAMMING.....	PAGE 13 –17
• OPTION MODES	
• ERROR CODES	
QUICK TROUBLESHOOTING.....	PAGE 18 –19
• PROBLEMS AND SOLUTIONS	
GAME REPAIR.....	PAGE 20 –23
• GLASS REPLACEMENT	
• MECHANICAL REPAIR	
• ELECTRICAL / ELECTRONIC REPAIR	
PARTS LISTINGS.....	PAGE 24
CRANE ASSEMBLY DIAGRAMS.....	PAGE 25 –28
SCHEMATICS / WIRING DIAGRAMS.....	PAGE 29 –47
WARRANTY INFORMATION.....	PAGE 48

INTRODUCTION

GAME FEATURES

Thank you for your purchase of the new **JEWELRY CRANE™** game from I.C.E.

The brand new **JEWELRY CRANE™** all metal crane game by I.C.E. was designed with the operator in mind. Reliability, low maintenance, themed cabinetry and all metal construction are the key design features, exactly what is needed to ensure a combination of long life and high profit.

With nearly the entire construction made of metal, it was only natural to Powder Epoxy Coat everything, inside and out. This provides the owner-operator with a game that will certainly outlast its wooden counterparts for many years to come. The major advantages of all metal construction include:

- Vault like security
- Long service life
- Low maintenance
- High durability

All windows of the **JEWELRY CRANE™**, are 1/4" tempered plate glass to provide an easy to clean, maximum safety, scratch resistant surface. Other features include: 41 strand conductor cables (to prevent fatigue), a full range of operator adjustable software and a newly designed crane mechanism.

The first step in I.C.E.'s new crane design was to select several leading cranes available on the market today, observe and determine what problems can be or are causes of failure and costly down time. I.C.E. then surveyed operators nation wide, requesting information like:

- What are the leading causes of crane failures in your locations
- What are some problems in servicing cranes
- What changes would you make to current cranes to create a better machine

I.C.E.'s engineers then compiled all critical data, addressed and corrected each problem and used this information to create what we now call the **JEWELRY CRANE™**.

This method of design ensures that the needs of the owner-operators dictate the final design parameters, for who knows a cranes attributes and faults better than a crane operator.

GAME PLAY

As coins are inserted into the **JEWELRY CRANE™** all metal game, a "Ding" is heard for each coin inserted. When sufficient coins have been inserted, the claws click closed and then reopen, which signals the start of the game. The crane will then position itself in the middle of the "play field*" and remain there, until the player is ready.

When the player has moved the joystick or pressed the buttons to move the crane, the timer on the right display will begin to count down. The player will then position the crane above the prize they are attempting to win and press the drop button to lower the claw.

If the nudging option is on, then the player will have the ability to keep "nudging" the claw each time the button is pressed to home in on the chosen prize. If the nudging option is off, then the player will have only one chance to drop the claw.

When the claw has fully dropped, it will close and retract to its uppermost position. The crane will then automatically position itself over the prize chute at the rear of the cabinet. The claw will then open, releasing the prize into the prize chamber. The player can now remove the prize from the chamber through the prize door located in the front, lower left corner of the game. The game is now at its home position and is ready for the next player in line.

SETUP / TESTING / MAINTENANCE

BEFORE YOU BEGIN

IMPORTANT: FAILURE TO FOLLOW THESE DIRECTIONS CLOSELY COULD CAUSE SERIOUS DAMAGE TO YOU AND/OR YOUR GAME.

WARNING: WHEN INSTALLING THIS GAME, A 3 PRONG GROUNDED A.C. RECEPTACLE MUST BE USED. FAILURE TO DO SO COULD RESULT IN INJURY TO YOURSELF OR OTHERS. FAILURE TO USE A GROUNDED RECEPTACLE COULD ALSO CAUSE IMPROPER GAME OPERATION, AND / OR DAMAGE TO THE ELECTRONICS

DO NOT DEFEAT OR REMOVE THE GROUNDING PRONG ON THE POWER CORD FOR THE SAME REASON AS GIVEN ABOVE. USING AN IMPROPERLY GROUNDED GAME COULD VOID YOUR WARRANTY.

HAVE A QUALIFIED ELECTRICIAN CHECK YOUR A.C. RECEPTACLE TO BE SURE THE GROUND IS FUNCTIONING PROPERLY.

GAME SET-UP

BEFORE PLUGGING THE GAME IN OR TURNING IT ON, BE SURE THE GAME HAS BEEN SET TO THE PROPER VOLTAGE.

ASSEMBLY INSTRUCTIONS

1. Carefully unbox the game from its packaging.
2. Using the supplied keys, unlock the front door of cabinet.
3. Cut all tie wraps holding the wagon assembly and crane assembly in place.
4. Plug the game into a three prong grounded receptacle. **NOTE:** The appliance must be positioned such that the plug is accessible during use.
5. The game is now ready for start up.

TESTING

After the initial setup, it is time to test your game for proper operation.

1. Locate the game in its permanent location and lock the casters.
2. Be sure that the game has been properly plugged into a three prong grounded outlet and that the receptacle is in good working order.
3. If using an extension cord, be sure it is a three prong grounded type of at least 16 Ga.
4. Verify that the game is set up for the proper voltage and turn the power to the game on.
5. The game will run through a test mode at every start up. See test mode explanation in the programming section for details.
6. Insert coins/bills at least ten times into the coin mech/bill acceptor to assure proper operation.
7. Check the credit and prize counters for proper operation.
8. Check that the door disconnect switch works properly.
9. Check game volume during busy time at location to set it at the proper level.

CLEANING

Regular cleaning of the game will keep it looking new and greatly enhance its appeal.

Clean the windows of your **JEWELRY CRANE™** with a standard window cleaner such as Windex®

Clean the cabinet sides with a good cleaner such as "Fantastik" or "409" and a soft rag. A mild soapy solution can also be used.

NOTE: DO NOT USE ALCOHOL, THINNERS OF ANY KIND OR PINBALL PLAYFIELD CLEANERS ON ANY OF THE CABINET SURFACES, ESPECIALLY THE DECALS.

IF YOU HAVE ANY QUESTIONS OR COMMENTS REGARDING INSTALLATION OR PROPER FUNCTION OF YOUR GAME, PLEASE CALL OUR SERVICE DEPARTMENT AT 1-716-759-0360

SETUP / TESTING / MAINTENANCE

MANUAL SETTING

Initial adjustment tips

- It is important to know that a mechanical adjustment is considered a “Macro adjustment” or a large adjustment, and that a software adjustment is considered a “Micro adjustment” or a fine adjustment.
- NOTE: These adjustments need only be performed when setting up the crane for the first time or when major changes to plush size and/or shape occur. Once a configuration is determined for your particular requirements, the same configuration in another CRANE GAME may require only minor adjustments.
- It is advisable that you position your plush such that the “Eyes” are facing forward and looking at your potential customers.
- To maintain proper payout in either Manual mode or Skill leveling mode, ALL plush in the crane should be of similar size, shape and weight. DO NOT attempt to use 6” plush with 14” plush in the same crane as you are likely to have very different payout % from week to week which requires constant monitoring and adjusting.
- Set option 0 (Game mode) for game type you desire.
- Set option 3 (Game cost) for you particular game.
- For the following tests, make sure that option 9 (Skill leveling strength) is set to 00. Any setting other than 00 and Skill leveling is enabled and incorrect results may occur.
- Make sure that the claw tips, when closed, are just touching. DO NOT allow them to overlap, for the claw could mechanically bind, causing down time.
- CHECK IF YOU HAVE THE CORRECT CLAW SHAPE. Assuming you have a medium claw, standard on most cranes, set option 8 to 40, 9 to 00 and play the game approximately 25 times. At this level, you should have difficulty picking up plush.
 - If you are able to pick up plush rather easy, you have the wrong claw shape or size and should go to the end of this section and see CLAW SHAPE.
 - If you are unable to pick up plush, then set option 8 to 99 and play 25 games. You should now be able to pick up plush fairly consistently. If this is true, continue on to the next step. NOTE: When the game is first packed, it is often difficult to pick up plush until an area is cleared to maneuver in. Take this in to account while determining if the claw size or shape is correct.
- Initially set option 8 (Manual strength) based on your plush size, such that the claw is just able to hold the plush when closed. If you are unsure, a good starting point for option 8 is 60 for average size plush and our standard medium claw. NOTE: When in programming mode at option 8, the claw will begin the open and close at approximately 5 second intervals. The operator can then associate the claw strength number on the right display with an actual “physical” claw strength at the claw.
- Knowing the cost of a game, the average cost of a piece of plush and the desired payout %, calculate the proper plush dispensing intervals for your setup, using the following formula:

SETUP / TESTING / MAINTENANCE

Calculation Option 1

- 1) $100 * (\text{Game cost}) = A$ (# of dollars received for 100 games)
- 2) $A * (\text{Desired payout \%}) = B$ (# of dollars worth of plush that should be dispensed in 100 games)
- 3) $B / (\text{Cost of plush}) = C$ (# of pieces of plush that should be dispensed in 100 games)
- 4) $100 / C = Y$ (Proper plush dispensing intervals)

OR

Calculation Option 2

- 1) $(\text{Plush Cost}) / (\text{Game Cost}) = X$ (# of games required to pay for one piece of plush)
- 2) $(X) / (\text{Desired Payout \%}) = Y$ (Proper plush dispensing interval)

EXAMPLE

Game cost	= \$0.50
Avg. cost of 1 plush	= \$2.00
Desired payout %	= 33%

Example Calculation Option 1

- 1) $100 * (\$0.50) = \50
- 2) $\$50 * (.33) = \16.5 worth of plush in 100 games to give a 33% payout
- 3) $\$16.5 / (\$2.00) = 8.25$ pieces of plush per 100 games to give a 33% payout
- 4) $100 / (8.25) = 12.12$ round off to 12.

OR

Example Calculation Option 2

- 1) $\$2.00 / (\$0.50) = 4$
- 2) $(4) / (.33) = 12.12$ round off to 12

NOTE: This means that for approximately every 12th game played, 1 piece of plush should be won.

SETUP / TESTING / MAINTENANCE

Armed with the information particular to your game (Proper plush dispensing intervals determined above) play at least 50 games and see if the correct number of plush have been dispensed. (For the example above, in 50 games you should have dispensed approximately 4 pieces of plush. (Every 12.12 games) NOTE: The more games you play during the "TEST", the more accurate your accounting will be). When 50 games have been played, calculate the payout % using the formula below:

$$1) \frac{(\# \text{ of plush dispensed}) * (\text{Cost of 1 pc. of plush})}{(\# \text{ of games played}) * (\text{Cost of game})} = \text{Payout \%}$$

EXAMPLE

Cost of a game	= \$0.50
Cost of 1 pc. of plush	= \$2.00
# of plush dispensed	= 55
# of games played	= 423

$$\frac{(55) * (\$2.00)}{(423 * (\$0.50))} = 52 = 52\% \text{ payout}$$

If the calculated payout is very high, your desired payout + 10% or more, it will be necessary to make a macro adjustment or move the claw tips apart slightly by loosening the three screws holding the claw slider to the coil housing and moving the claw slider up slightly. (See Fig. 1) **NOTE: MOVING THE CLAW SLIDER 1/8th OF AN INCH COULD CHANGE YOUR PAYOUT BY AS MUCH AS 40%. BE SURE TO MOVE THE SLIDER IN VERY SMALL INCREMENTS SO AS NOT TO OVERSHOOT YOUR DESIRED PAYOUT.**

If the calculated payout is slightly high, your desired payout + less than 10%, then you can make a micro adjustment or software claw strength adjustment at Option 8.

Conversely, if the calculated payout is very low or slightly low, you will need to make a macro or micro adjustment accordingly.

Repeat the 50 games test and calculate the Payout %. Repeat the mechanical adjustment until you are within 10% of your desired payout. You can now enter the programming mode and adjust Option 8 (Mechanical strength) up or down slightly to achieve your desired payout. Your game is now set up according to your Desired Payout, Game Cost and Plush Cost.

If after using the initial adjustment tips above, you are still having difficulty in setting up your game, please call the I.C.E. service line at 1-716-759-0360.

SETUP / TESTING / MAINTENANCE

SKILL LEVELING SETTINGS

Initial adjustment tips

- Before setting up Skill leveling, it is highly advisable to set up manual percentaging. This is a precaution in the unlikely event that the prize sensor fails or error code 10 or 11 is logged. If either one of these situations occurs, the game will AUTOMATICALLY revert to manual percentaging settings, allowing the game to still function until the error is corrected. If your manual settings are not set up, it may be possible to dispense too much plush resulting in a loss of revenue for that week, or dispensing too little plush, causing your customers to feel as though they can not win, which will eventually result in a loss of play and revenue.
- It is important to know that a mechanical adjustment is considered a “Macro adjustment” or a large adjustment, and that a software adjustment is considered a “Micro adjustment” or a fine adjustment.
- **SPECIAL NOTE:** When using Skill leveling, you will be required to reset the computer memory once a week. This is done to clear computer memory of “portions” of plush that were to be dispensed and have not been OR “portions of plush that have not been dispensed and should not have been. Since we are human, we think of plush as whole entities. The computer has the ability to track plush as pieces or fractions of pieces. For example: If we want a 34% payout based on \$2.00 average cost plush and \$0.50 game play, we want APPROXIMATELY 1 piece of plush dispensed every 12 games. The actual number is 1 piece of plush for every 11.7647 games. The computer from week to week may have a bunch of the little pieces of plush that it did not give away and will eventually add up and hit the limit of 8 pieces not dispensed and take you out of Skill leveling Mode. Often this confuses an operator since the game worked very well for several weeks or even longer, but then kicked into Manual Mode and gave them an Error 11. To prevent this, it is HIGHLY suggested you reset the computer once a week using the following procedure:

Once a week, or after a minimum of 500 games, enter the programming mode and change the % payout number up by one number and exit programming mode. The following week, enter the programming mode and change the % payout number down by one number. Example: Week one, the % payout number = 33. Week two, change % payout to 34. Week three, change % payout number back to 33, etc. Using % payout will have the smallest change on payout yet it will reset memory and keep things working as intended.

- NOTE: These adjustments need only be performed when setting up the crane for the first time or when major changes to plush size and / or shape occur. Once a configuration is determined for your particular requirements, the same configuration in another CRANE GAME may require only minor adjustments.
- It is advisable that you position your plush such that all “Eyes” are facing forward and looking at your potential customers.
- To maintain proper payout in either Manual Mode or Skill leveling Mode, ALL plush in the crane should be of similar size, shape and weight. DO NOT attempt to use 6” plush with 14” plush in the same crane as you are likely to have very different payout % from week to week which requires constant monitoring and adjusting.
- Set Option 0 (Game mode) for game type you desire
- Set Option 3 (Game cost) for your particular game.
- Make sure that the claw tips, when closed, are just touching.
- To check if you have the correct claw shape, set Option 8 to 50, Option 9 to 00 and play the game approximately 25 times. At this level, you should have difficulty picking up plush.

SETUP / TESTING / MAINTENANCE

- If you are able to pick up plush, you have the wrong claw shape or size and should go to the end of this section and see CLAW SHAPE
- If you are unable to pick up plush, then set Option 8 to 99 and play 25 games. You should now be able to pick up plush fairly consistently. If this is true, continue on to the next step. NOTE: When the game is first packed, it is often difficult to pick up plush until an area is cleared to maneuver in. Take this into account while determining if the claw size or shape is correct.
- Make sure Option 8 (Manual strength) is set up as detailed above before setting up Skill leveling.
- Determine the proper Minimum Claw Strength by setting Option to 9 initially to 60 on the right display. Notice that the claw is opening and closing on a 5 second interval. Hold an average size piece of plush in the claw as it closes and note whether it has enough claw strength to hold the plush. Repeat this procedure until you find the breaking point where the claw will hold the piece of plush but if you lower the strength of the claw by 1 or 2 points, the claw will no longer be able to hold the plush. This will be the number you want to use as your Skill leveling strength (Option 9). It will allow a skilled player to move plush around and have the ability to win at any time, yet requires a skilled player to win easily.
- Set Option 16 (Plush cost) based on the cost of your plush.
- Set Option 17 (Desired payout %) based on your desired payout.
- Knowing the cost of a game, cost a piece of plush and the desired payout %, calculate the proper plush dispensing intervals using the following formula:

Calculation Option 1

- 1) $100 * (\text{Game cost}) = A$ (# of dollars received for 100 games)
- 2) $A * (\text{Desire payout \%}) = B$ (# of dollars worth of plush that should have been dispensed in 100 games)
- 3) $B / (\text{Cost of plush}) = C$ (# of pieces of plush that should be dispensed in 100 games)
- 4) $100 / C = Y$ (Proper plush dispensing intervals)

OR

Calculation Option 2

- 1) $(\text{Plush Cost}) / (\text{Game cost}) = X$ (# of games required to pay for one piece of plush)
- 2) $(X) / (\text{Desired payout \%}) = Y$ (Proper plush dispensing interval)

EXAMPLE

Game cost	= \$0.50
Avg. cost of 1 plush	= \$2.00
Desired payout %	= 33%

Example Calculation Option 1

- 1) $100 * (\$0.50) = \50
- 2) $\$50 * (.33) = \16.5 worth of plush in 100 games to give a 33% payout
- 3) $\$16.5 / (\$2.00) = 8.25$ pieces of plush per 100 games to give a 33% payout
- 4) $100 / (8.25) = 12.12$ round off to 12

OR

SETUP / TESTING / MAINTENANCE

Example Calculation Option 2

$$1) \$2.00 / (\$0.50) = 4$$

$$2) (4) / (.33) = 12.12 \text{ round off to } 12$$

NOTE: This means that for approximately every 12th game played, 1 piece of plush should be won.

Armed with the information particular to your game (Proper plush dispensing interval determined above) play at least 50 games and see if the correct number of plush have been dispensed. (For the example above, in 50 games you should have dispensed approximately 4 pieces of plush. (Every 12.12 games) NOTE: The more games you play during the "TEST", the more accurate your accounting will be). When 50 games have been played, calculate the payout % using the formula below:

$$1) \frac{(\# \text{ of plush dispensed}) * (\text{Cost of 1 pc. Of plush})}{(\# \text{ of games played}) * (\text{Cost of game})} = \text{Payout \%}$$

EXAMPLE

Cost of a game	= \$0.50
Cost of 1 pc. Of plush	= \$2.00
# of plush dispensed	= 55
# of games played	= 423

$$\frac{(56) * (\$2.00)}{(423 * (\$0.50))} = 52 = 52\% \text{ payout}$$

If the calculated payout is very high, your desired payout + 10% or more, it will be necessary to make a macro adjustment or move the claw tips apart lightly by loosening the three screws holding the claw slider to the coil housing and moving the claw slider up slightly. (See Fig. 1) NOTE: MOVING THE CLAW SLIDER 1/8TH OF AN INCH COULD CHANGE YOUR PAYOUT BY AS MUCH AS 40%. BE SURE TO MOVE THE SLIDER IN VERY SMALL INCREMENTS SO AS NOT TO OVERSHOOT YOUR DESIRED PAYOUT.

If the calculated payout is slightly high, your desired payout + less than 10%, then you can make a micro adjustment or software claw strength adjustment at Option 8.

Conversely, if the calculated payout is very low or slightly low, you will need to make a macro or micro adjustment accordingly.

Repeat the 50 games test and calculate the Payout %. Repeat the mechanical adjustment until you are within approximately 5 - 10% of your desired payout. You can now enter the programming mode and adjust Option 9 (Skill leveling strength) up or down slightly to achieve your desired payout. Your game is now set up according to your Desired Payout, Game Cost and Plush Cost. If at a later date you want to change your game cost, desired payout, plush cost, etc., it is NOT necessary to re-adjust your game manually. Just adjust the value option you wish to change in the PROGRAMMING SECTION. The game will adjust to your new configuration.

If after using the initial adjustment tips above, you are still having difficulty in setting up your game, please call the I.C.E. service line at 1-716-759-0360.

SETUP / TESTING / MAINTENANCE

CLAW SHAPE

In an attempt to satisfy all variables associated with proper payout, I.C.E. has opted to include directions on how to reshape your medium claw for a lesser and greater mechanical advantage. On the following page are two medium claw shapes which will give very different mechanical advantages and ultimately very different claw strengths.

- When Option 8 is set to 50, and you are still picking up plush, then you will need to reshape your 3 claws to look more like shape "A". (SEE FIG. 2) NOTE: Be sure to align holes in claw with drawn holes on the template. This will assure proper shaping of the claw.
- When Option 8 is set to 99, and you are unable to pick up plush consistently, then you will need to reshape your 3 claws to look more like shape "B". (SEE FIG. 2) NOTE: Be sure to align holes in claw with drawn holes on the template. This will assure proper shaping of the claw.

These are two claw shapes that I.C.E. has proven to work well, although there are many other shapes that may work. You will need to remove the claws from the claw mechanism by following the steps listed below.

- 1) Remove the claw mechanism from the coil housing by loosening the three screws on the coil slider and removing. Be sure not to lose the small spring around the plunger and the black Rynite washer below the spring. These two parts are critical in the proper operation of the crane mechanism. (SEE FIG. 1)
- 2) Loosen and remove the six small Phillips head machine screws and Nylock nuts attaching the three claws to the coil-claw interconnect and coil spider. (SEE FIG.1)
- 3) Reshape the claws according to the CLAW SHAPE Templates "A" or "B".
- 4) Re-assemble in reverse order. Make sure NOT to over tighten the Nylock nuts attaching the claws to the mechanism, as this would cause binding.

Now that you have reshaped your claws for your plush, return to the beginning of Adjustment tips and proceed through each step.

FIG. 1

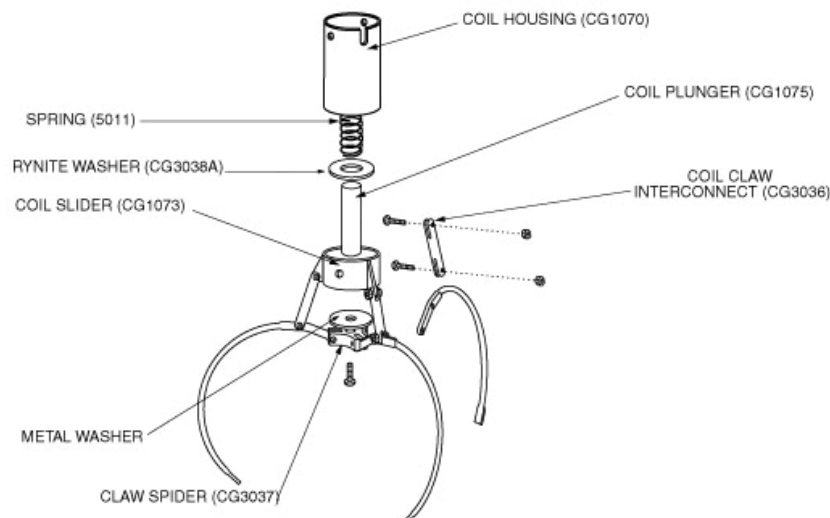

CLAW TEMPLATES

(Fig. 2)

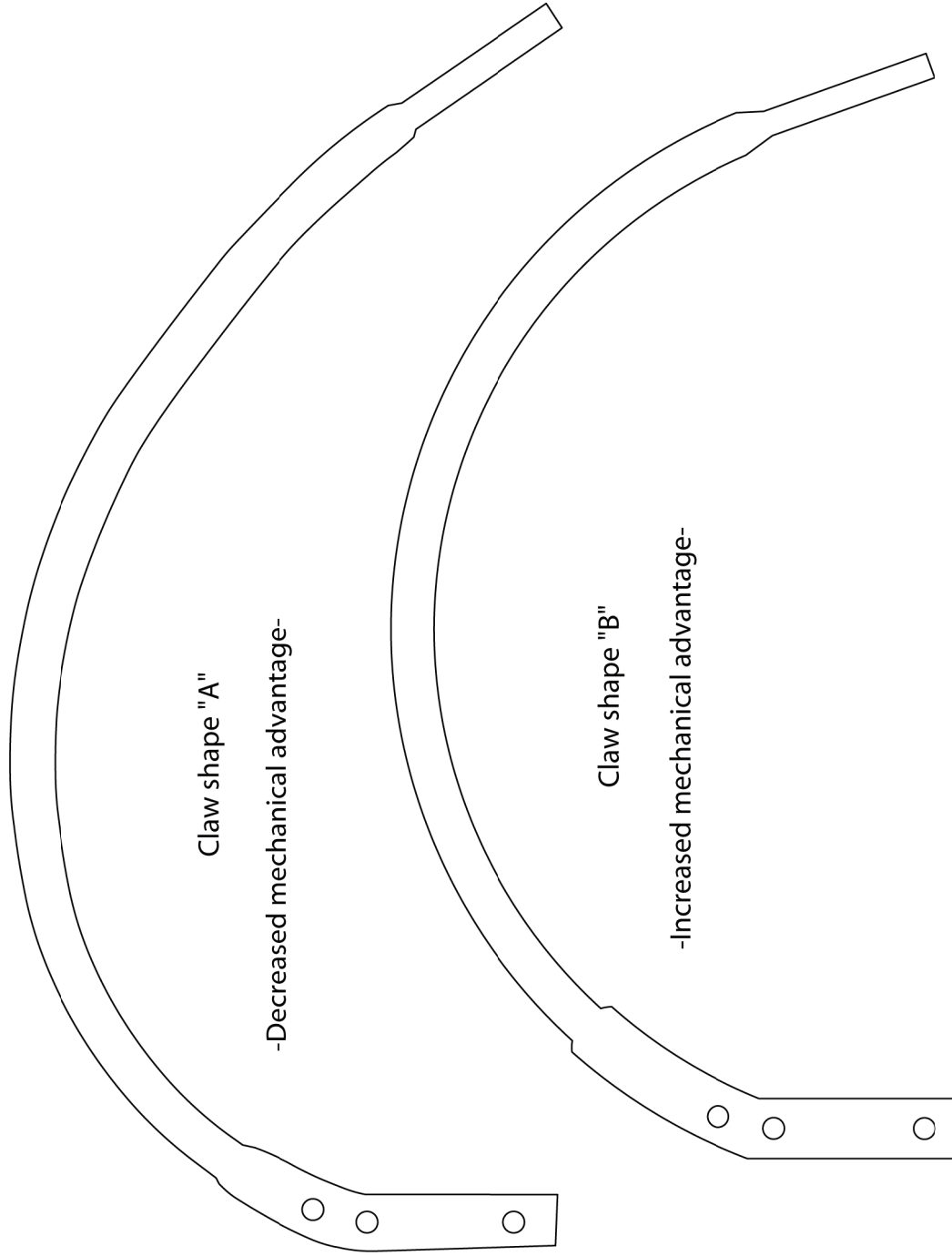

NOTE: These are the two claw shapes that have been thoroughly tested by I.C.E. and are proven to work. They should be used as a guide to increase or decrease the mechanical advantage of the claw for your particular plush. Other claw shapes in-between claw shapes A and B may work but will require further testing.

PROGRAMMING

<u>MODE</u> (Credit Display)	<u>DESCRIPTION</u>	<u>MIN / MAX / DEF</u> (Timer Display)	<u>MEANING</u>
<u>BASIC PROGRAMMING</u>			
0	Game Type	0, 4, 0	0—Left, Right, Forward, Backward, Nudge 1—Left, Right, Forward, Backward, Drop 2—Right, Forward, Nudge 3—Right, Forward, Drop 4—Single, Move Drop
1	Game Mode	0, 1, 0	0—Normal Play 1—Play till you win
2	Time	10, 60, 20	10—60 Seconds (Inc. every 5 seconds)
3	Coin	0, 9, 2	0—Free Play 1—9 Coins required for a single credit
4	Bill	0, 9, 4	0—Off 1—9 Number of coins each bill is worth
5	Counter Type	0, 1, 0	0—Credit counter 1—Coin counter
6	Attract	0, 30, 20	0—30 Minutes between attract modes 0—Off
7	Attract Type	1, 2, 2	1—Motion only 2—Audio and motion
8	Manual Strength	60, 99, 60	60—99 Claw strength Inc. by 1 (99= MAX)
<u>ADVANCED PROGRAMMING</u>			
9	Skill Leveling Strength	0, 99, 0	0—Skill leveling off 40—99 Claw strength in skill (99 = MAX)
10	F / B Speed	10, 20, 20	10 = Low speed 20 = High speed
11	L / R Speed	10, 20, 20	10 = Low speed 20 = High speed
12	Up Speed	15, 20, 20	10 = Low speed 20 = High speed
13	Down Speed	15, 20, 20	10 = Low speed 20 = High speed
14	Right Time	0, 40, 8	0—40 Number of 1/4 sec. time intervals right
15	Forward Time	0, 40, 5	0—40 Number of 1/4 sec. time intervals forward
16	Plush Cost	1, 20, 4	Coins per piece of plush
17	Payout	20, 50, 33	20—50 Desired payout percentage
18	Tickets to Play	0, 99, 0	0—99 tickets to be paid just to play game
19	Tickets if Lose	0, 99, 0	0—99 tickets to be paid if you do not win plush
20	Factory Default	0, 1, 0	0—Normal 1—Restore factory defaults upon next startup
21	Center On / Off	0, 1, 0	0—Center option off 1—Center option on
22	Snap On / Off	0, 1, 1	0—Snap option off 1—Snap option on
23	Up / Down Motor Test	DIAG.	Right display changes: 0—1 Up switch is made 0—2 Down switch is made 0—3 Both switches are made
24	Left / Right Motor Test	DIAG.	Right display changes: 0—1 Left switch is made
25	Front / Back Motor Test	DIAG.	Right display changes: 0—1 Back switch is made

PROGRAMMING

Mode Explanations

0. GAME TYPE—There are 5 game types:

- 0 Left, Right, Forward, Backward, Nudge—This mode is for a control panel that commonly has a joystick and allows the player to lower the claw each time the drop button is pressed. This allows the player to hone in on the prize they are attempting to win. NOTE: The crane will position itself according to the operator presets, options 14 and 15, at coin up if Option 21 is set to “0” (Off). The crane head will position itself according to the operator presets, options 14 and 15, at the end of the game if Option 21 is set to “1” (On).
- 1 Left, Right, Forward, Backward, Drop—This mode is for a control panel that commonly has a joystick and the claw drops fully when the drop button is pressed. NOTE: The crane will position itself according to the operator presets, options 14 and 15, at coin up if Option 21 is set to “0” (Off). The crane head will position itself according to the operator presets, options 14 and 15, at the end of the game if Option 21 is set to “1” (On).
- 2 Right Forward Nudge—This mode is for a control panel that commonly has 3 buttons, one to move right, one to move forward and one to drop the claw. The player also has the ability to lower the claw each time the drop button is pressed. This allows the player to hone in on the prize they are attempting to win. NOTE: Option 21 is not available with this mode and will remain at “0” (off).
- 3 Right, Forward, Drop—This mode is for a control panel that commonly has 3 buttons, one to move right, one to move forward and one to drop the claw. The claw drops fully when the drop button is pressed. NOTE: Option 21 is not available with this mode and will remain at “0” (off).
- 4 Single Move Drop—This mode is for a control panel with two buttons only, one to move forward and one to move right. At coin up, the crane will remain over the prize chute to give the player full access to the playfield. The player will have a chance to move the crane once forward and once to the right, after which the claw will automatically drop.

1. GAME MODE—There are 2 game modes:

- Normal play—This is the standard type of play where a player has inserted enough coins to create 1 credit and then plays the game. Whether the player wins a prize or not, the game is over.
- Play till win—In this mode, the player has inserted enough coins to create 1 credit and will be able to play the game until they win a prize.

2. TIME—This option allows the operator to set the game play length. Options are from 10 seconds to 60 seconds in 5 second intervals.

3. COIN—This option allows the operator to set the number of coins needed to create 1 credit. A setting of “0” will put the game into free play.

4. BILL—This option allows the operator to set the number of coins each bill is worth. A setting of “0” turns this option off.

5. COUNTER TYPE—Setting this option to “0” will have the game count credits on the mechanical and software counters. Setting this option to “1” will have the game count coins.

6. ATTRACT—This option allows the operator to set the number of minutes between attract modes. Available settings are from 0 minute to 30 minutes in 1 minute intervals. A setting of “0” turns off the attract mode.

7. ATTRACT TYPE—This option allows the operator to choose what type of attract mode they want.

- “1” will have an attract mode with movement only.
- “2” will have an attract mode with both audio and movement.

PROGRAMMING

8. MANUAL STRENGTH—This option allows the operator to set the strength of the claw for manual percentage. Available claw strengths are 40—99 with 99 = 100% claw strength. NOTE: When in this mode, the claw will open and close with the strength set in this mode. The operator will be able to feel each strength setting to determine which best suits their needs. When the correct strength setting is determined, the operator can just move to the next option, and the manual strength option is set.
9. SKILL LEVELING—This option allows the operator to set the claw strength for the skill leveling mode. Available claw strengths are 40—99 = 100% claw strength. NOTE: When in the auto skill leveling mode, the claw will, at bottoming, close with 100% strength and will then be backed off to the number set in this mode. i.e. With this mode set to 75, the claw will, at bottoming, close with 100% strength then back off to 75. NOTE: The claw will open and close allowing the operator to feel each strength setting to determine which best suits their needs. When the correct setting is determined, the operator can just move to the next option and the skill leveling option is set.
10. F / B SPEED—This option allows the operator to adjust the forward / backward speed of the crane. The available speeds are 10—20 with 10 being slow and 20 being fast.
11. L / R SPEED—This option allows the operator to adjust the left / right speed of the wagon. The available speeds are 10—20 with 10 being slow and 20 being fast.
12. UP SPEED—This option allows the operator to adjust the up speed of the crane. The available speeds are 15—20 with 15 being slow and 20 being fast.
13. DOWN SPEED—This option allows the operator to adjust the down speed of the crane. The available speeds are 15—20 with 15 being slow and 20 being fast.
14. RIGHT TIME—This option allows the operator to adjust the time the right drive motor will stay on, for centering purposes at game start up. Available time settings are 0—40 intervals of 1/4 sec. EXAMPLE: If this option is set at 5, then at coin up the right drive motor will stay on for $(5 * 1/4 \text{ sec.} = 1 \frac{1}{4} \text{ sec.})$ 1 1/4 sec. This option is used to correctly center the crane at coin up in different size cranes. An operator can also use this option along with Option 21, to adjust the position of the crane head when the game is over.
15. FORWARD TIME—This option allows the operator to adjust the time the forward drive motor will stay on, for centering purposes, at game start up. Available time settings are 0—40 intervals of 1/4 sec. EXAMPLE: If this option is set at 5, then at coin up the forward drive motor will stay on for $(5 * 1/4 \text{ sec.} = 1 \frac{1}{4} \text{ sec.})$ 1 1/4 sec. This option is used to correctly center the crane at coin up in different size cranes. An operator can also use this option along with Option 21, to adjust the position of the crane head when the game is over.
16. PLUSH COST—The operator will use this option to detail the cost of an average piece of plush used in their crane, in terms of the lowest denominator coin the game will accept. EXAMPLE: If the average cost of a piece of plush is \$1.50, and the lowest denominator coin used to coin up the game is \$0.25, then the number entered for this option will be 6. $(\$1.50/\$0.25 = 6)$ The available plush costs for this option are 1—20.
17. DESIRED PAYOUT—The operator will input the desired payout for the skill leveling mode. The available percentages for this option are 20% - 50%.

PROGRAMMING

18. TICKETS TO PLAY— This option is only used if you have a ticket dispenser. In this option, the operator has the ability to set the number of tickets that a player will be awarded just for playing the game. The available range is 0 - 99 tickets.
19. TICKETS IF LOSE—This option is only used if you have a ticket dispenser. In this option, the operator has the ability to set the number of tickets a player will be awarded when a piece of plush is not won. The available range for this option is 0 - 99 tickets.
20. FACTORY DEFAULTS—A setting of “0” for this option will keep the latest operator settings. A setting of “1” for this option will restore all options to factory defaults.
21. CENTERING—This option allows the operator to position the crane head any where on the play field. *If Option 21 is set to “0” (Off)* the crane head will position it at the beginning of the game according to the operator presets in Options 14 and 15. *If Option 21 is set to “1” (On)* the crane head will position itself at the end of the game according to the operator presets in Options 14 and 15.
22. SNAP—This option allows the operator to turn on and off the snap of the claws at the start of a game. *If Option 22 is set to “0” (Off)*, the claws will not snap together at the start of the game. *If Option 22 is set to “1” (On)*, the claws will snap together at the start of a game.
23. UP / DOWN MOTOR TEST—When the operator moves the joystick left and right, the claw will raise and lower respectively. The right display will change from:
0—1 If the up switch is made
0—2 If the down switch is made
0—3 If both switches are made
24. LEFT/ RIGHT MOTOR TEST—When the joystick is moved left and right, the wagon assembly will move to the left and right. The right display will change from: 0—1 If the left home switch is made
25. FRONT / BACK MOTOR TEST—When the joystick is moved left and right, the crane assembly will move forward and backwards. The right display will change from: 0—1 If the back home switch is made

Entering the Programming Mode

To enter the programming mode, open the front door and press the button marked PROG, located near the main board, and the crane will move to the front center of the game. NOTE: The game WILL NOT go into the programming mode if the door is “closed”, or the door switch has been pulled to its outer most position. Once you are in the programming mode, move the joystick forward and backward to move through the modes. To change the value of the mode, move the joystick left and right. Once all options have been set, press the drop button and the game will return to regular game play with the new settings.

Entering the Accounting Mode

To enter the accounting mode, unlock and open the front door and press the button marked ACCOUNT, located near the main board. The left displays will flash between “cr” (Credits) then the number of credits 1 - 9999. If the operator presses the drop button, the displays will flash “pl” (Plush) then the number of plush that has passed through the sensor. These numbers can never be reset and WILL NOT match the numbers on the mechanical counters from the counters. It is advisable that the owner note this difference so that they will be able to track actual software coins / credits and plush out vs. the mechanical counters for accounting purposes.

PROGRAMMING

Test Mode Explanation

Every time that the game is powered up, the door is closed or exiting programming mode, the game will run through a test mode to check the following items:

- HOME BACK SWITCH
- HOME LEFT SWITCH
- UP SWITCH
- DOWN SWITCH
- FRONT / BACK MOTOR
- LEFT / RIGHT MOTOR
- CREDIT / COIN DISCONNECT
- CLAW CLOSE, CLAW OPEN
- PRIZE SENSOR
- OUT OF RANGE
- E² (MEMORY)

If any of the above items are malfunctioning, the game will light up the 4 decimal points on the podium displays. This will alert the operator that there has been a problem. The operator needs only unlock and open the front door and the error codes will be displayed one at a time on the left display. To move to the next error code, the operator needs to press the drop button. Repairs should be made to those areas in which errors have been logged. When all codes have been seen, and the door is closed, the game will reset the error codes, run through a test mode to check for proper operation and if all is well, game play can start. If not, the 4 decimals will once again light up and the operator will need to check the error codes again. Game play can continue to the best of the machine's abilities, with problems, until the errors are corrected. At no time should the game be inoperable unless a key component is damaged.

Error code 10 / 11 will alert the operator that the game has paid out 8 too many or 8 too little pieces of plush when in skill leveling. If this error is logged, the game will automatically revert to MANUAL settings until one of the following options has been changed. (COST OF PLUSH, SKILL % MIN., % PAYOUT, OR GAME COST) This is why it is imperative that the manual setting be setup before skill leveling is used.

NOTE: Changing one of these options will reset error code 10 / 11 and the game will begin skill leveling with the new settings.

NOTE: Some items on the list can not be detected by the game and require that the operator watches for these actions to be performed during the start up test mode. (Claw close, Claw open)

Error Codes

<u>#</u>	<u>Problem</u>	<u>Solution</u>
1	E ² (Memory)	Replace Microprocessor
2	Prize Sensor	Check / Replace Prize Sensor
3	Up Sensor	Check / Replace Up Sensor
4	Down Sensor	Check / Replace Down Sensor
5	Left / Right Sensor	Check / Replace L /R Sensor
6	Front / Back Sensor	Check / Replace F /B Sensor
7	Front / Back Motor	Check / Replace F / B Motor
8	Left / Right Motor	Check / Replace L / R Motor
9	Counter Disconnect	Just a warning that the credit / coin counters were disconnected at some time.
10	Out Of Range (High)	Change setting for the Cost of Plush, Skill leveling Min, % Payout or Game Cost
11	Out Of Range (Low)	Change setting for the Cost of Plush, Skill leveling Min, % Payout or Game Cost

QUICK TROUBLESHOOTING

PROBLEM	PROBABLE CAUSE	SOLUTION
THE DECIMALS ON THE 4 DISPLAYS ARE LIT UP	THIS IS IN FACT NOT A PROBLEM BUT A WAY OF LETTING THE OPERATOR KNOW THAT THERE WAS A PROBLEM DURING THE START UP MODE	OPEN THE FRONT DOOR AND THE ERROR CODES ARE SHOWN ON THE DISPLAYS. TO ADVANCE THROUGH THE ERROR CODES, PRESS THE FIRE BUTTON
NO GAME POWER	ON-OFF SWITCH ON THE GAME IS TURNED OFF BLOWN A.C. POWER FUSE GAME NOT PLUGGED OR CORD DAMAGED BAD TRANSFORMER TRANSFORMER HARNESS NOT CONNECTED BAD POWER MODULE	TURN POWER ON REPLACE WITH PROPER FUSE CHECK POWER CORD CHECK FOR PROPER VOLTAGES CHECK HARNESS REPLACE POWER MODULE
GAME WILL NOT TAKE MONEY OR GIVE CREDITS CORRECTLY	BAD COIN SWITCH COIN DISCOUNTING SET WRONG COINS PER CREDIT SETTING INCORRECT BAD COIN MECHANISM LOOSE OR DAMAGED HARNESSING BAD MAIN P.C. BOARD	CHECK W/METER AND REPLACE CHECK PROGRAMMABLE SETTING CHECK PROGRAMMABLE SETTING ADJUST OR REPLACE CHECK W/METER—REPAIR REPAIR OR REPLACE MAIN BOARD
DISPLAYS DO NOT WORK	BAD 12V FUSE BAD DISPLAY P.C. BOARD BAD MAIN P.C. BOARD LOOSE OR DAMAGED DISPLAY HARNESSING	REPLACE WITH PROPER FUSE REPAIR OR REPLACE P.C. BOARD REPAIR OR REPLACE P.C. BOARD CHECK W / METER AND REPAIR
CRANE OR WAGON DOES NOT MOVE	BAD MOTOR LOOSE OR DAMAGED HARNESSING BAD SWITCH ON BUTTON OR JOYSTICK BAD HARNESSING TO BUTTONS OR JOYSTICK BLOWN FUSE TO MOTORS ON MAIN P.C.B.	REPLACE MOTOR CHECK W / METER—REPAIR REPLACE SWITCH CHECK W / METER—REPAIR REPLACE WITH PROPER FUSE
CRANE KEEPS TRYING TO MOVE IN TO THE HOME POSITION	BAD LIMIT SWITCH (S) LIMIT SWITCH NOT ALIGNED WITH ACTUATOR	REPLACE SWITCH (S) ALIGN SWITCH AND ACTUATOR
CLAW WILL NOT CLOSE	BLOWN FUSE TO CLAW ON MAIN P.C. BOARD BAD COIL LOOSE OR DAMAGED HARNESSING CLAW HAS MECHANICALLY JAMMED	REPLACE WITH PROPER FUSE REPLACE COIL CHECK W / METER AND REPAIR FIND JAM AND REPAIR
CLAW STAYS CLOSED	BAD DRIVE TRANSISTOR ON MAIN P.C.B. CLAW HAS MECHANICALLY LOCKED	REPLACE TRANSISTOR FIND JAM AND REPAIR
SKILL LEVELING IS NOT FUNCTIONING	PROGRAMMING IS NOT CORRECTLY SET BAD PRIZE SENSOR LOOSE OR DAMAGED SENSOR HARNESS	SET OPTIONS "9", "16" AND "17" REPLACE PRIZE SENSOR CHECK W / METER AND REPAIR
CLAW GOES DOWN AND THEN UP BUT DOES NOT CLOSE	DOWN SWITCH BAD LOOSE OR DAMAGED HARNESS TO DOWN SWITCH	REPLACE DOWN SWITCH CHECK W / METER AND REPLACE
CLAW COMES UP AND ABOUT 10 SEC. PASSES BEFORE CRANE MOVES TO THE HOME POSITION	UP SWITCH BAD LOOSE OR DAMAGED HARNESS TO UP SWITCH BROKEN "UP" SPRINGS	REPLACE UP SWITCH CHECK W / METER AND REPLACE REPLACE SPRINGS
CRANE OR WAGON WHEELS SLIP	MISSING OR DAMAGED O-RING DRIVE BELTS LOOSE SET SCREWS IN WHEELS LOOSE SET SCREWS IN DRIVE COUPLER RAILS NEED TO BE SCUFFED	REPLACE O-RING BELTS TIGHTEN SET SCREWS TIGHTEN SET SCREWS SCUFF TOP OF RAILS WITH SANDPAPER

QUICK TROUBLESHOOTING

- NOTE: A self test will be performed each time the front door is “closed” , the game is powered up, or when you exit programming mode.
- NOTE: The game will not count credits or plush out on either the mechanical or software counters while the front door is open.
- NOTE: If the Wagon does not move smoothly through a full travel from left to right, check to see that the wheel spacing is correct. If the spacing is correct, then check the 2 cabinet rails for burrs that may cause the wheels to bind.
- NOTE: If the Crane does not move smoothly through a full travel from front to back, check to see that the wheel spacing is correct. If the spacing is correct, then check the 2 separator rails for burrs that may cause the wheels to bind.
- NOTE: If the Micro track for the left / right movement is binding during its travel, check to see if the top mirror bracket's edge, also the shelf the micro track rides on, has been de-burred.
- NOTE: If the front door is having trouble closing fully, check to see that all harnessing is out of the way for the door to close. Next, check to see that the prize chamber wall is far enough to the right to allow the right edge of the prize door frame to swing past. Finally, check to see that the door is aligned properly.
- NOTE: If the door will not lock properly or locks with difficulty, check to see that the lock rotates smoothly. Next, check that the lock rods are not binding on the lock cam or the lock rod guides. Next, check that all friction points have been lubricated with molly grease. Finally, if need be, adjust the lock rod guides such that the door closes and locks smoothly.
- NOTE: If the decimals light up on the displays after a self test, an error has been logged. When the door is in the open position, the error codes will be shown on the left display. To advance through the error codes, press the drop button.
- NOTE: If at the beginning of the self test mode, the claw does not drop, one or more of the following may apply. The prize sensor is not working or is blocked. The string or string lever is mechanically binding. The up or down switch is sticking or misaligned from its actuator.
- NOTE: If claw stays closed, it is likely that the diode has blown and the transistor controlling the claw has also blown. Shut off the game immediately and have a qualified technician install a new coil assembly and transistor on main board.
- NOTE: If claw is jerky while being lowered, it is likely that the up spring is missing or has not been slightly elongated properly. Another possibility is that the string has mechanically bound on the spool. To fix the string binding, enter the programming mode and go to mode 24. By moving the joystick to the left and right, you are able to raise and lower the claw mechanism. Move the crane over the prize chute and lower the claw mechanism all the way until it starts to wind up backwards. Reverse the motor direction to raise the claw mechanism and properly rewind the string on the spool. Exit the programming mode and the string should be free of mechanical binding.
- NOTE: If the claw stays open, first check for bad fuses on the main board. Next check that there are no wires dislodged from the connectors in the harness between the wagon and crane, the harness between the wagon and the main board, the crane assembly and the wagon assembly. If the problem still exists, and no fuses are blown or wires dislodged, it is likely that the transistor controlling voltage to the claw has blown on the main board. Have the coil assembly and transistor on the main board replaced by a qualified technician.
- NOTE: If the crane / wagon, in the home position, tries to move left or back, check to see that the actuators are both present. Next, check to see that the sensors are present. Next, check to see that the sensors and actuators are aligned. Then check to see that the sensor wires are not dislodged from the connectors. Finally, replace the sensor, it is likely to be bad.

GAME REPAIR

WARNING: ALWAYS REMOVE POWER FROM THE GAME BEFORE ATTEMPTING ANY SERVICE, UNLESS NEEDED FOR SPECIFIC TESTING. FAILURE TO OBSERVE THIS PRECAUTION COULD RESULT IN SERIOUS INJURY TO YOURSELF AND / OR OTHERS.

TROUBLESHOOTING PHILOSOPHY

To find problems with the game, always check the obvious first. See that the game is plugged in and that all of the fuses are good.

Next, check to see that all of the connectors are firmly seated and that no wires have been pulled out.

When trying to find out if specific components are bad or not, try swapping them with components from another **JEWELRY CRANE™** game, if available, to see if the problem moves with the component or stays where it was. This will help you decide if you have a problem with a specific component or maybe a problem with either the wiring or the main p.c. board. Use extreme caution when using probes or volt meters if the game is powered up. If checking continuity, it is important to disconnect the harnessing at both ends, as attached they may yield erroneous results.

If a p.c. board is suspected as causing your problems, check to see that all of the I.C. chips are firmly seated on the board.

MAIN P.C. BOARD REPLACEMENT

1. Remove all A.C. power from the game
2. Unlock and open the front door
3. Carefully remove all of the connectors from the main p.c. board.
4. Remove the 4 long plastic hexagon nuts that secure the board to the main board housing.
5. Gently pull the p.c. board from the mounting studs.
6. Reassemble in the reverse order using a new main p.c. board.

FRONT GLASS REPLACEMENT

1. Remove all A.C. power from the game.
2. Remove the (3) 10-24 carriage bolts holding the top glass frame in place.
3. Loosen the (5) 1/4-20 kep nuts holding each side glass retainer in place and slide retainers back.
4. Loosen and remove the (3) self tapping screws holding the bottom glass retainer / window valance in place.
5. If the glass is broken, be sure to remove all pieces from where the new glass will rest.
6. With proper ceiling height, slide the new glass in from the top. NOTE: Be careful to proper align the glass with the side channels to prevent breakage.
7. When glass is properly seated, slide the side glass retainers into place and tighten the (5) 1/4-20 kep nuts for each side.
8. Re-install the bottom glass retainer and tighten into place via the (3) self tapping screws
9. Re-install the top window frame and tighten into place via the (3) 10-24 carriage bolts.

SIDE GLASS REPLACEMENT

1. Remove all A.C. power from the game.
2. Remove wagon and crane assemblies.
3. Remove front and rear cabinet rails and hardware.
4. Remove fluorescent lights and brackets on side where glass is to be replaced.
5. Remove (2) side window retainers and (1) top window retainer.
6. Remove side marquee.
7. Back out long 1/4-20 bolts that hold on the side window retainers so they are flush with the 1" tube frame.

GAME REPAIR

8. Remove bolts holding playfield in place near bottom of the glass.
9. Install new glass from the inside of the game and drop into channel in the playfield.
10. Reinstall retainers, lights, brackets, marquee, playfield bolts and rails in reverse order.

PLUSH RETAINER WALL REPLACEMENT

1. Remove all A.C. power from the game.
2. Unlock and open front door
3. Carefully remove the (2) 1/4-20 nuts holding the plastic plush retainer / wall to the side of the game.
4. Remove old plastic plush retainer wall
5. Reassemble in reverse order using new plastic plush retainer wall.

REMOVAL OF CRANE MECHANISM

1. Remove all A.C. power from the game.
2. Unlock and open the front door.
3. Slide the crane assembly to the front center of the game.
4. Loosen black thumb screw securing the front to back micro track bracket in place. The thumb screw is located on the front face of the crane assembly nearest the door.
5. Slide the micro track bracket forward and up to disconnect it from the crane assembly.
6. Carefully lift the entire crane assembly off the rails approximately 2 inches, shift to the left as far as possible, drop the right side down past the right crane rail and slide the entire assembly out from between the two separator rails.
7. The crane assembly can now be removed from the cabinet so necessary maintenance / repairs can be made
8. Reassemble in reverse order.

REMOVAL OF WAGON ASSEMBLY

1. Remove all A.C. power from the game.
2. Unlock and open front door.
3. Remove crane assembly as detailed previously.
4. Loosen black thumb screw securing the micro track bracket in place. The thumb screw is located on the upper right face of the wagon assembly at rear.
5. Slide the micro track bracket to the right and up to disconnect it from the wagon assembly.
6. Carefully lift the entire wagon assembly off the rails and rotate clockwise until the left front wheel clears the front rail.
7. Lower the front of the wagon assembly and remove the assembly from between the two rails.
8. The wagon assembly can now be removed from the cabinet so necessary maintenance / repairs can be made.
9. Reassemble in reverse order.

PRIZE SENSOR REPLACEMENT

1. Remove all A.C. power from the game.
2. Unlock and open the front door.
3. Disconnect the connector to the prize sensor board.
4. Remove the 2 bolts holding the prize sensor bracket to the playfield and remove the prize sensor and bracket from the game.
5. Remove the 2 plastic hexagonal nuts securing the sensor board to the bracket.
6. Carefully remove the sensor board from its mounting studs.
7. Reassemble in reverse order using a new prize sensor board.

GAME REPAIR

STRING REPLACEMENT

1. Remove all A.C. power from the game.
2. Unlock and open front door.
3. Remove crane assembly as previously stated.
4. Disconnect the claw assembly from the crane assembly by removing the two bolts securing the aluminum coil cap to the coil housing.
5. Tie a knot at the end of the replacement string. Use super glue to prevent the knot from working loose or use a lighter to melt the knot to prevent loosening.
6. Using a lighter, melt the other end of the string and form a point before it completely cools.
7. Remove crane housing cap by loosening the (2) thumbscrews.
8. Feed the pointed end up through the hole in the coil cap and pull until the knot is firmly seated on the inside of the cap. SEE CRANE ASSEMBLY DRAWING
9. A proper string routing diagram is located on the bottom side of the crane housing cap.
10. Feed the pointed end up through the hole in the bottom of the crane assembly housing.
11. Feed string over first string guide then under the next string guide.
12. Finally, feed the string through the hole in the side of the string spool, attached to the motor shaft, and tie another knot. (Once again, either use super glue to prevent the knot from working loose or use a lighter to melt the knot to prevent loosening)
13. The string is now properly strung.
14. Re-attach the claw assembly to the crane assembly using the two bolts that were removed in step 4.
15. Re-install the crane assembly into the game and set it in the home position with the claw assembly hanging in the prize chute.
16. Turn on the game and the crane will automatically rewind the string properly.

MOTOR REPLACEMENT

1. Remove all A.C. power from the game.
2. Unlock and open front door.
3. Remove crane and / or wagon assembly as previously stated. NOTE: What is removed depends on which motor has gone bad.
4. Loosen two thumb screws securing crane housing cap in place and remove. NOTE: This step is only for the 2 motors in the crane assembly.
5. Remove drive o-rings and wheels from the bad motor.
6. De-solder the motor leads from the bad motor. NOTE: Be sure to note which wire goes to which motor lead, for if they are re-installed backwards, the motor will run opposite of its intended direction.
7. Carefully remove the bronze bushing supporting the motor shaft of the bad motor. NOTE: This step is only for the 2 motors in the crane assembly.
8. Remove the 4 bolts securing the motor to the housing.
9. Carefully remove the bad motor.
10. Re-assemble in reverse order using new motor. NOTE: When motor is completely re-installed, place one drop of thread lock on each of the 4 bolts that secure the motor in place to prevent the bolts from backing out.

PRECAUTION

When installing a new motor in any of the three locations, please note that the 4 screws, if tightened too much, could mis-align the motor and cause binding. It is advisable that you tighten the 4 screws just enough to keep the motor from moving. Then apply a small drop of (Blue) loctite on the back side of each of the 4 screws to prevent the screws from loosening. When the motor is installed properly, it should draw .5 amps or less when running at proper 22 volts.

GAME REPAIR

FUSE REPLACEMENT

CAUTION FOR CONTINUED PROTECTION AGAINST RISK OF FIRE. REPLACE ONLY WITH THE SAME TYPE OF FUSE HAVING THE SAME ELECTRICAL RATING.

<u>AREA</u>	<u>LOCATION</u>	<u>AMP</u>	<u>VOLT</u>
MAIN BOARD	F2	6 MDQ	250
	F3	3 MDQ	250
	F4	4 MDQ	250
POWER MOD	—	3 MDQ	250
ROPE LIGHT CONTROLLER	—	3 MDQ	250

CORD REPLACEMENT

IF THE SUPPLY CORD IS DAMAGED, IT MUST BE REPLACED BY THE MANUFACTURER OR ITS SERVICE AGENT OR A SIMILARLY QUALIFIED PERSON IN ORDER TO AVOID A HAZARD.

PARTS LISTINGS

MECHANICAL PARTS

5011	SPRING
BC1002	LEFT REAR CORNER
BC1003	RIGHT REAR CORNER
BC1004	CABINET FRAME
BC1005	DOOR PANEL
BC1006	DOOR FRAME
BC1007	PRIZE DOOR
BC1008	SIDE PANEL
BC1011	SIDE WINDOW RETAINER
BC1013	LOCK CAM
BC1014	UPPER LOCK ROD
BC1015	LOWER LOCK ROD
BC1016	DOOR WHEEL BRACKET
BC1017	DOOR WINDOW FRAME TOP
BC1018	PODIUM
BC1022	REAR CORNER CAP
BC1023	DOOR SEAL
BC1025	FRONT WINDOW VALENCE
CG1020	FRONT / REAR CABINET RAIL
CG1052	3" SWIVEL CASTER
CG1055X	WAGON ASSEMBLY
CG1061X	CRANE ASSEMBLY
CG1054	WAGON ROLLER SHAFT
CG1069X	TRACK MOUNT RAIL ASSEMBLY
CG2008	MOTOR / GEARBOX
CG3019X	THUMB SCREW
C3030	WHEEL
CG4003	O-RING DRIVE BAND
CG1062	CRANE MOTOR HOUSING CAP
CG1066	CRANE UP SPRING
CG1070	COIL HOUSING
CG1073	COIL SLIDER
CG1075	COIL PLUNGER
CG1078A	SMALL CLAW
CG1078B	MEDIUM CLAW
CG1078D	JUMBO CLAW
CG3036	COIL CLAW INTERCONNECT
CG3037	CLAW SPIDER
CG4004	STRING
CG2014	JOYSTICK
CG3008	MICRO TRACK 56 LINK
CG3009	MICRO TRACK 35 LINK
CG3013	COIN FUNNEL
BC3026	MIRROR
BC3027	FRONT GLASS
BC3028	SIDE GLASS
CG5014	LOCK T-HANDLE
CG5015	LOCK BARREL
BC9001	SERVICE MANUAL

GRAPHICS & DECALS

BC7007	DECAL SIDE MARQUEE
BC7013	DECAL CONTROL PANEL JOYSTICK
BC7015	DECAL CONTROL PANEL BUTTONS
BC7027	DECAL FRONT MARQUEE

ELECTRICAL / ELECTRONIC PARTS

2132	GE BRIGHT STICK
2970	DOOR SWITCH
FP2007	SWITCH
CG2012	F / B, UP, DOWN SENSOR
CG2013	L / R SENSOR
CG2010	F / B, UP, DOWN ACTUATOR
HH1020	L / R ACTUATOR
CG3038X	SOLENOID ASSEMBLY
CG2002	TRANSFORMER
BC2032X	DISPLAY PCB
CG2034X	MAIN PCB
2080	BRIDGE RECT. 10 AMP 400V
208004	VOLTAGE REG. IC LM338K
2110	TRANSISTOR TIP 122
2124	VOLTAGE REG. IC LM358
CG2039X	PRIZE SENSOR PCB
HD20224	5 V COUNTER
CG2600	DBV MARS SERIES 2000
BC3005	ABS FRONT CORNER VALANCE
BC3006	ABS REAR CORNER VALANCE

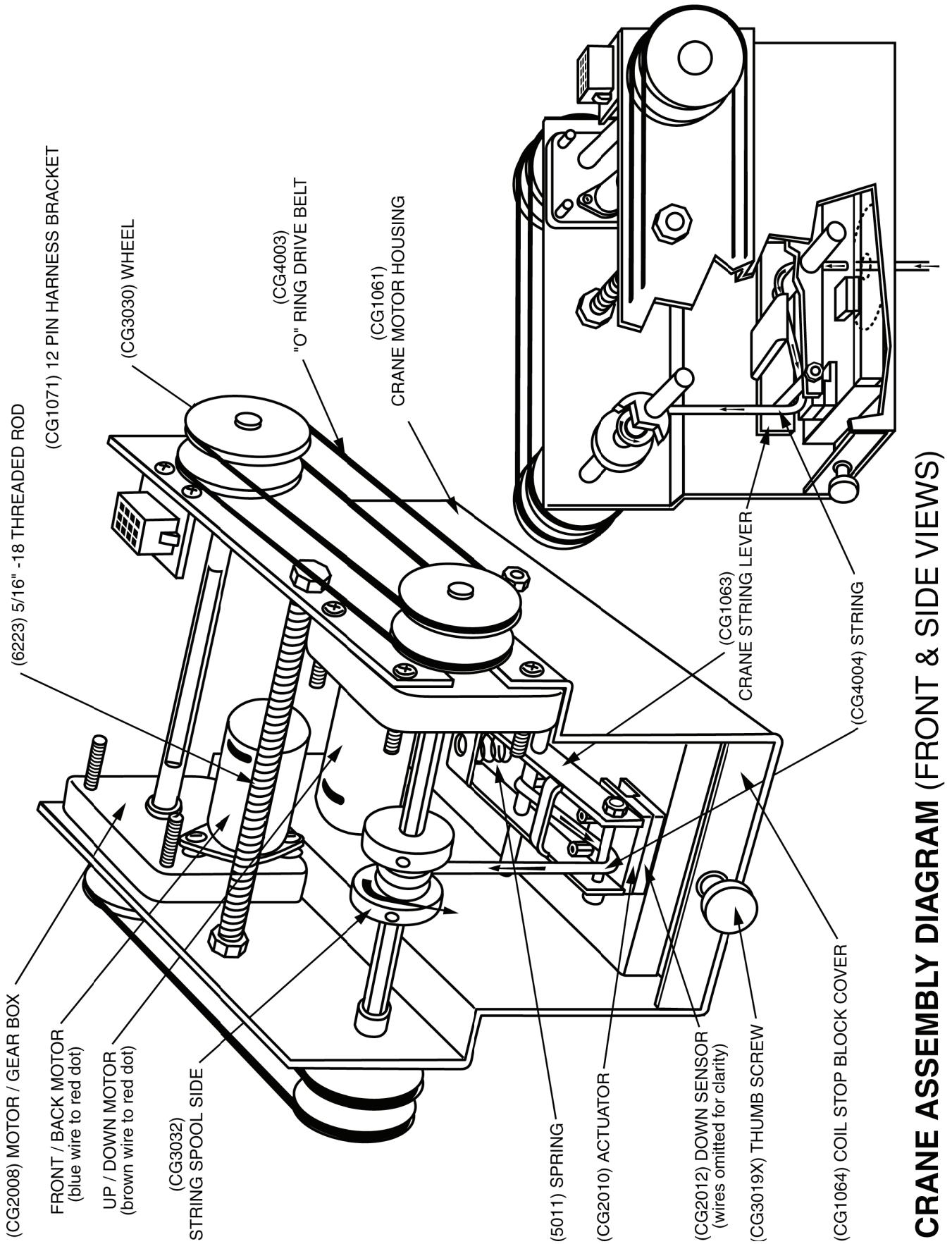

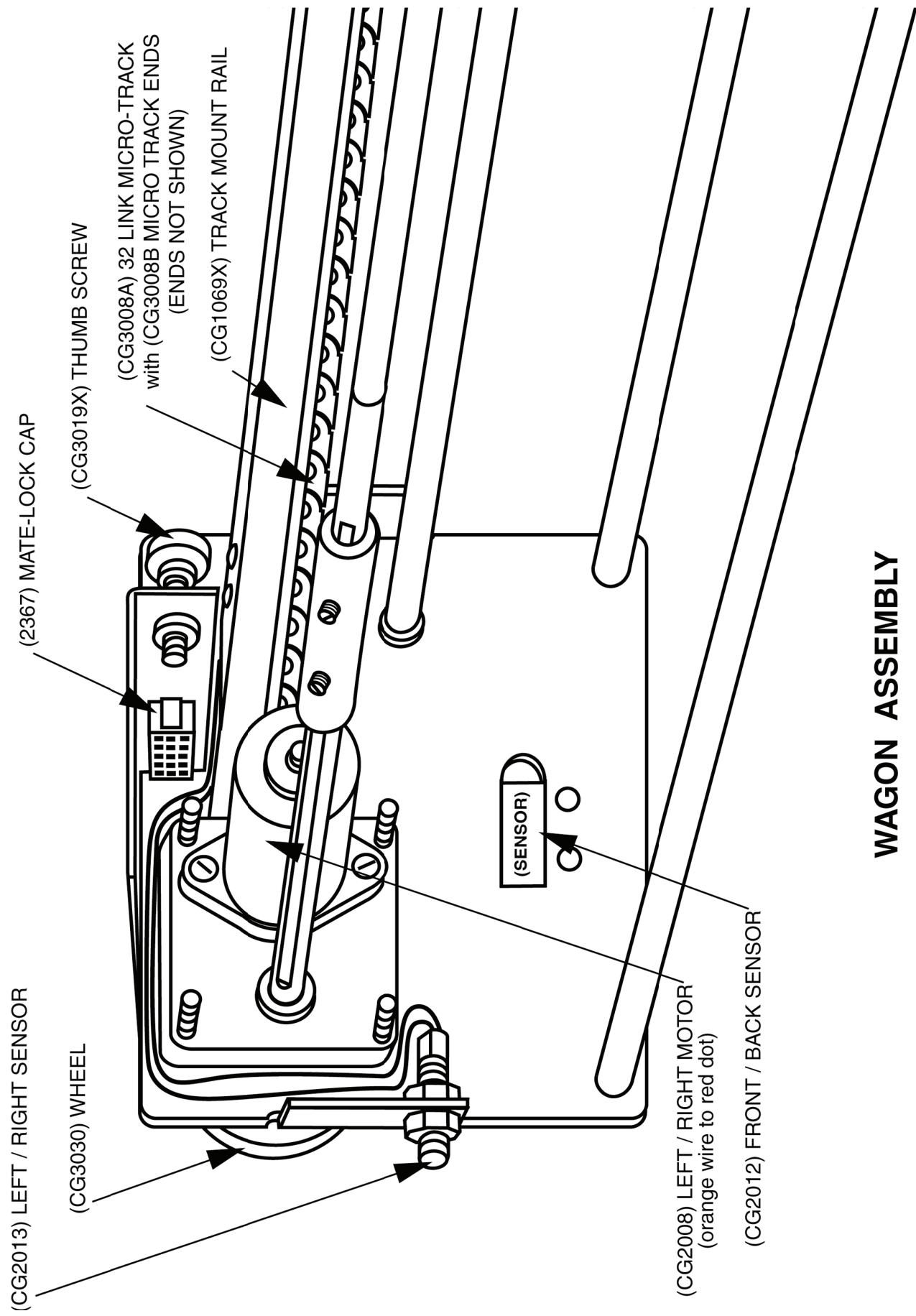

CLAW ASSEMBLY

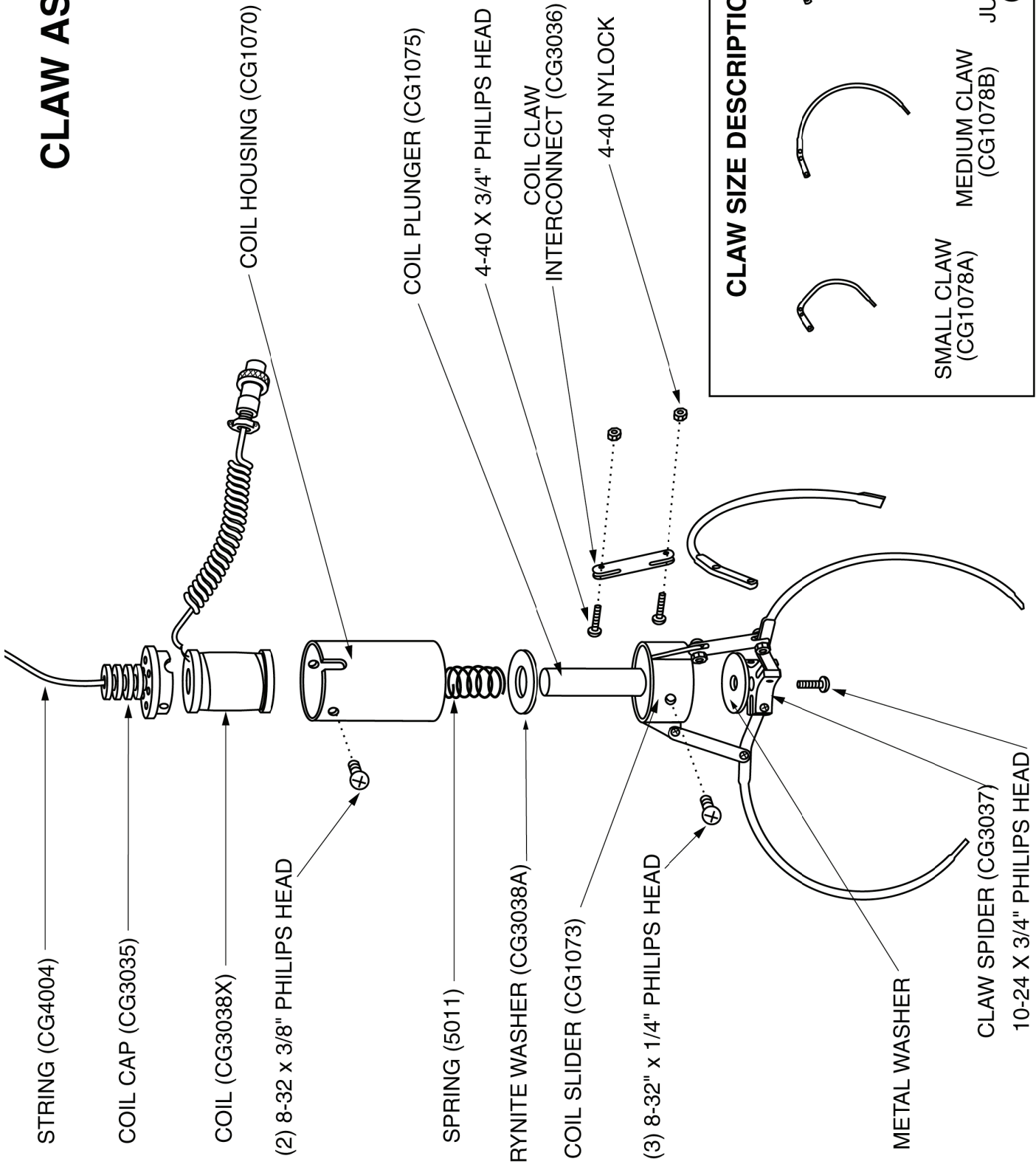

STRING ROUTING DIAGRAM

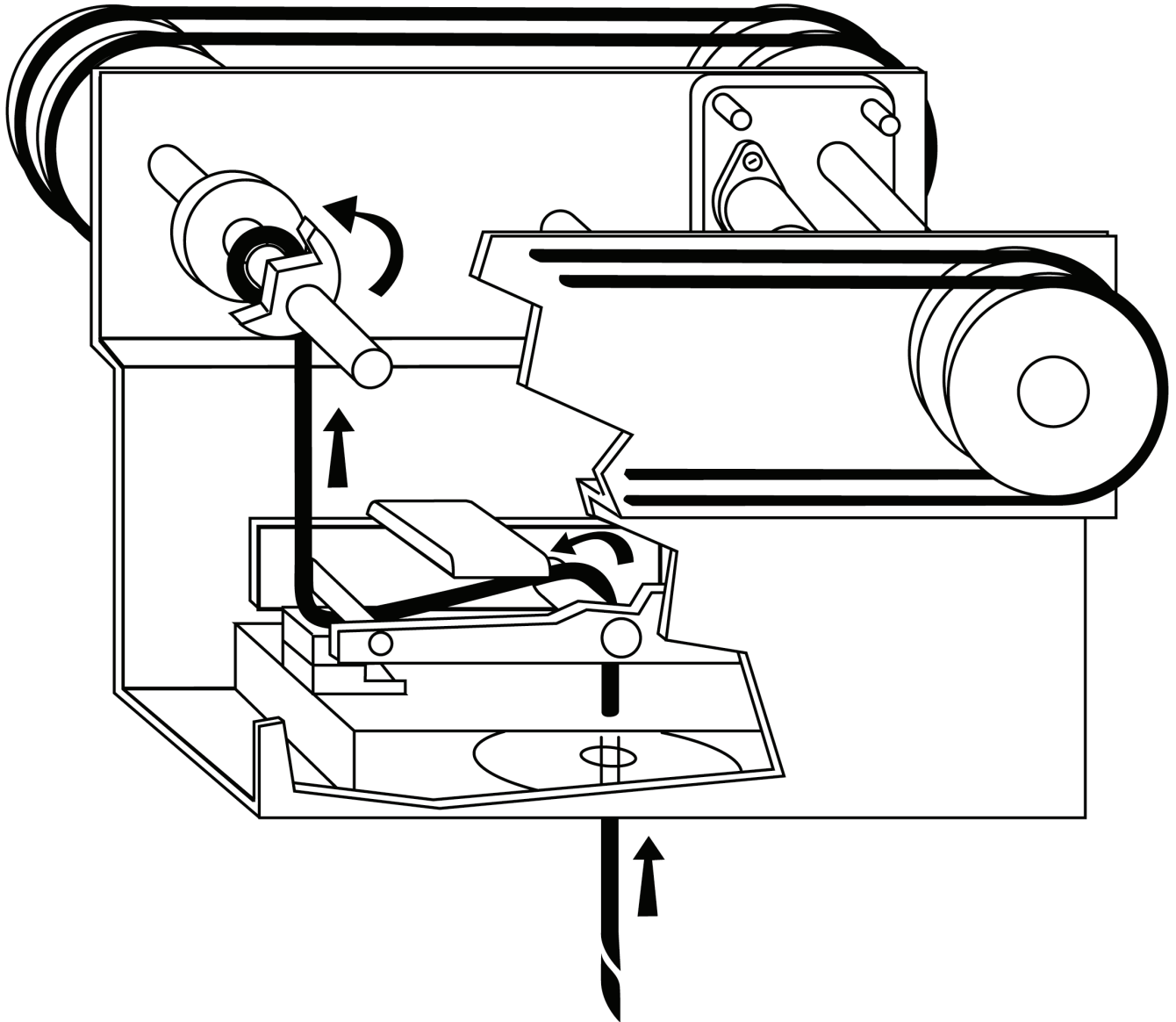

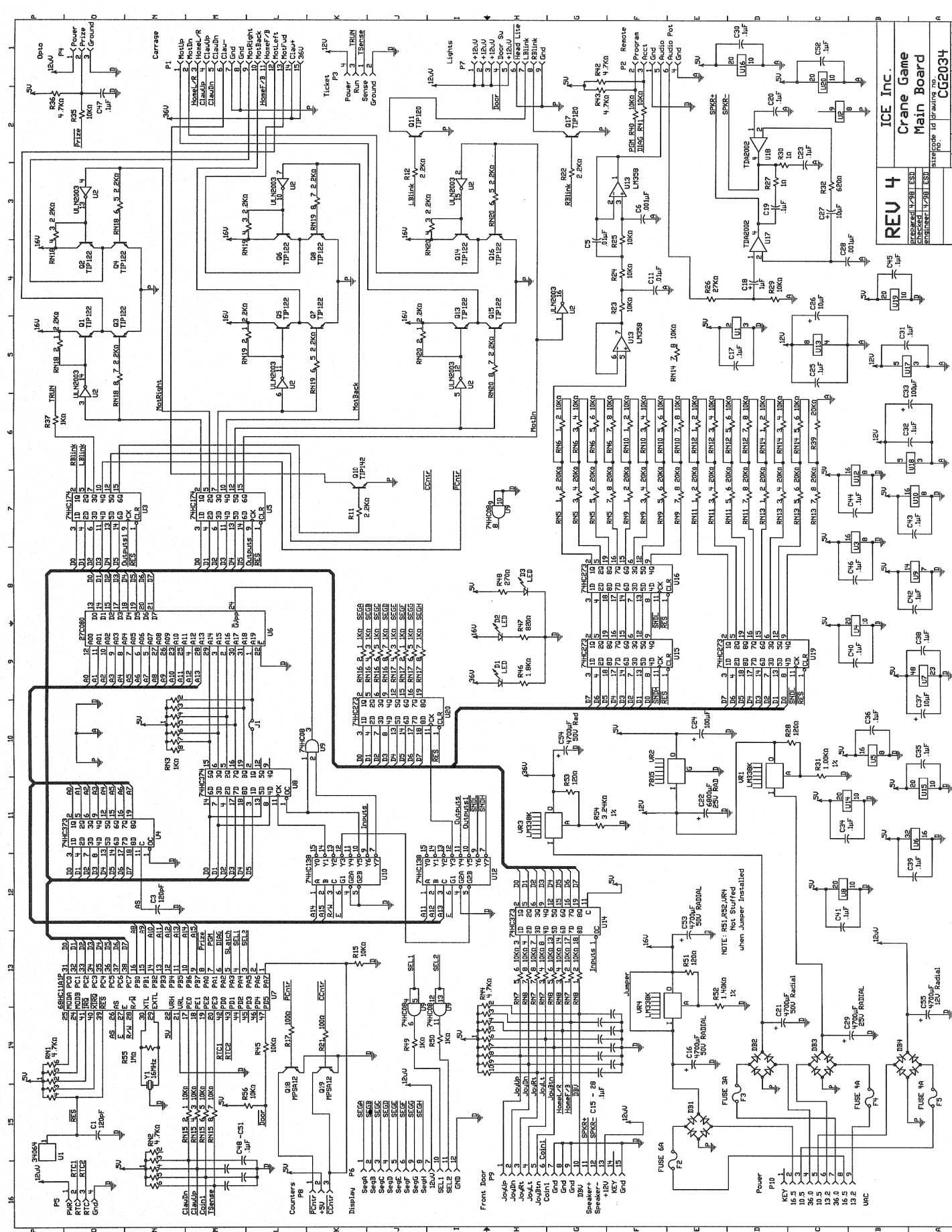

ICE Inc.
Crane Game
Main Board
REV 4
 REVISION 17298 1E50L
 REVISION 17298 1E50L
 STOP HERE TO PURCHASE
CGE034
 SCALE 1:1

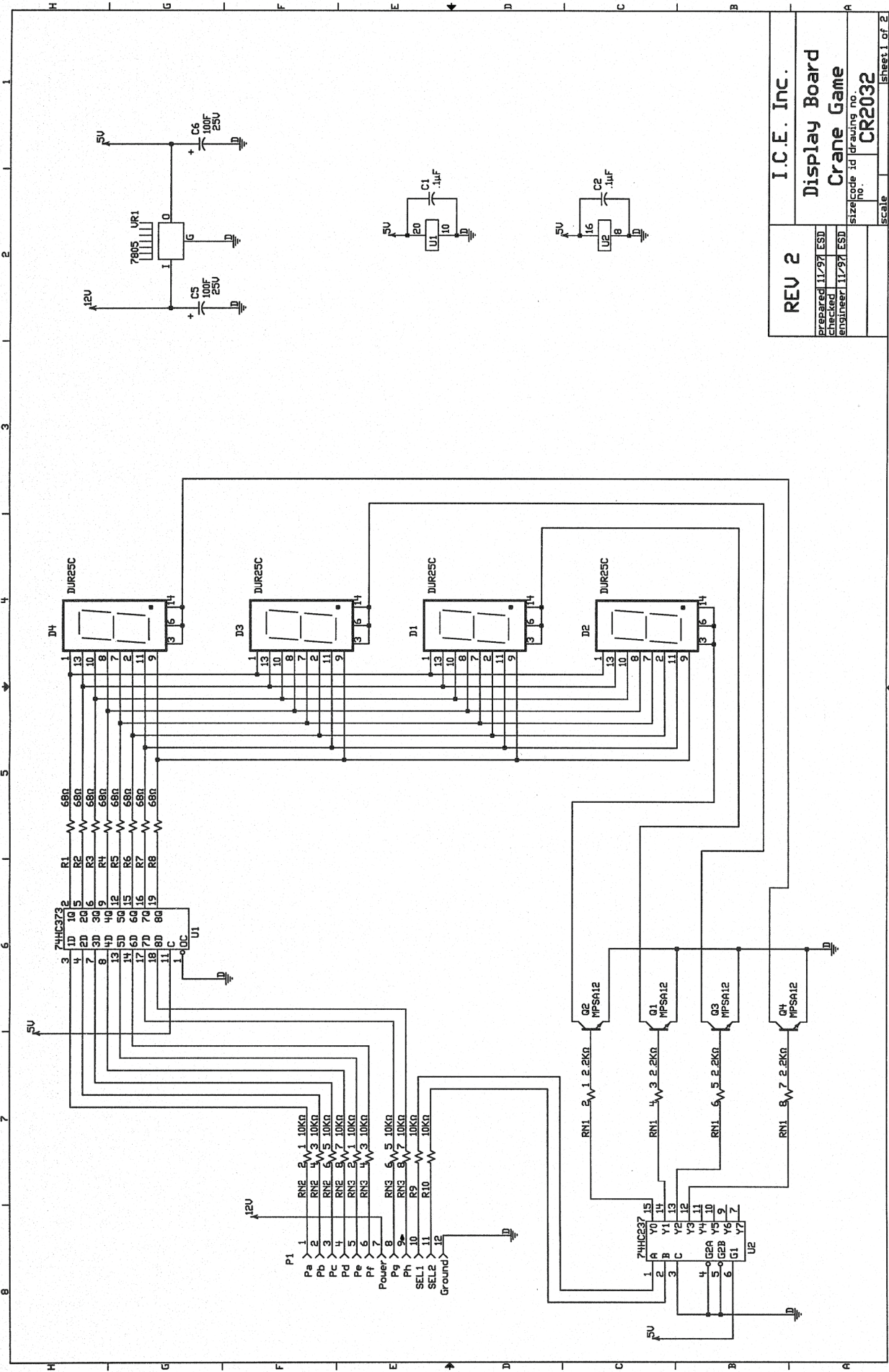

REV 2		I.C.E. Inc.	
Prepared	11/97 ESD	Display Board	
Checked	11/97 ESD	Crane Game	
Engineer	11/97 ESD	size code id drawing no.	
		CR2032	
		scale	sheet 1 of 2

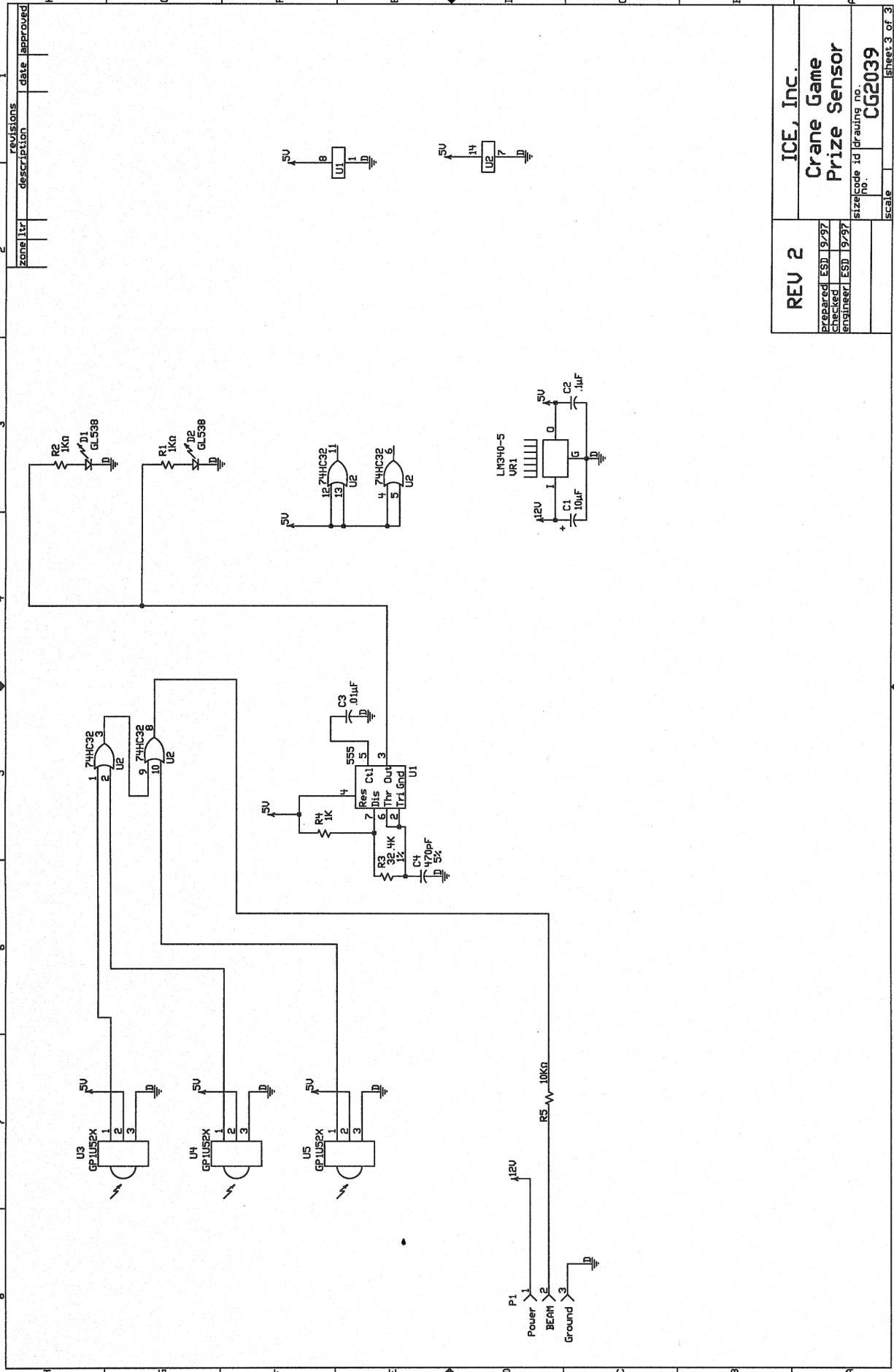

zone	ltr	description	date	approved

REV 2		ICE, Inc.	
Prepared	ESD 19/97	Crane Game Prize Sensor	
Checked	ESD 19/97	size/code id/drawing no.	
Engineer	ESD 19/97	no.	
scale		CG2039	
		sheet 3 of 3	

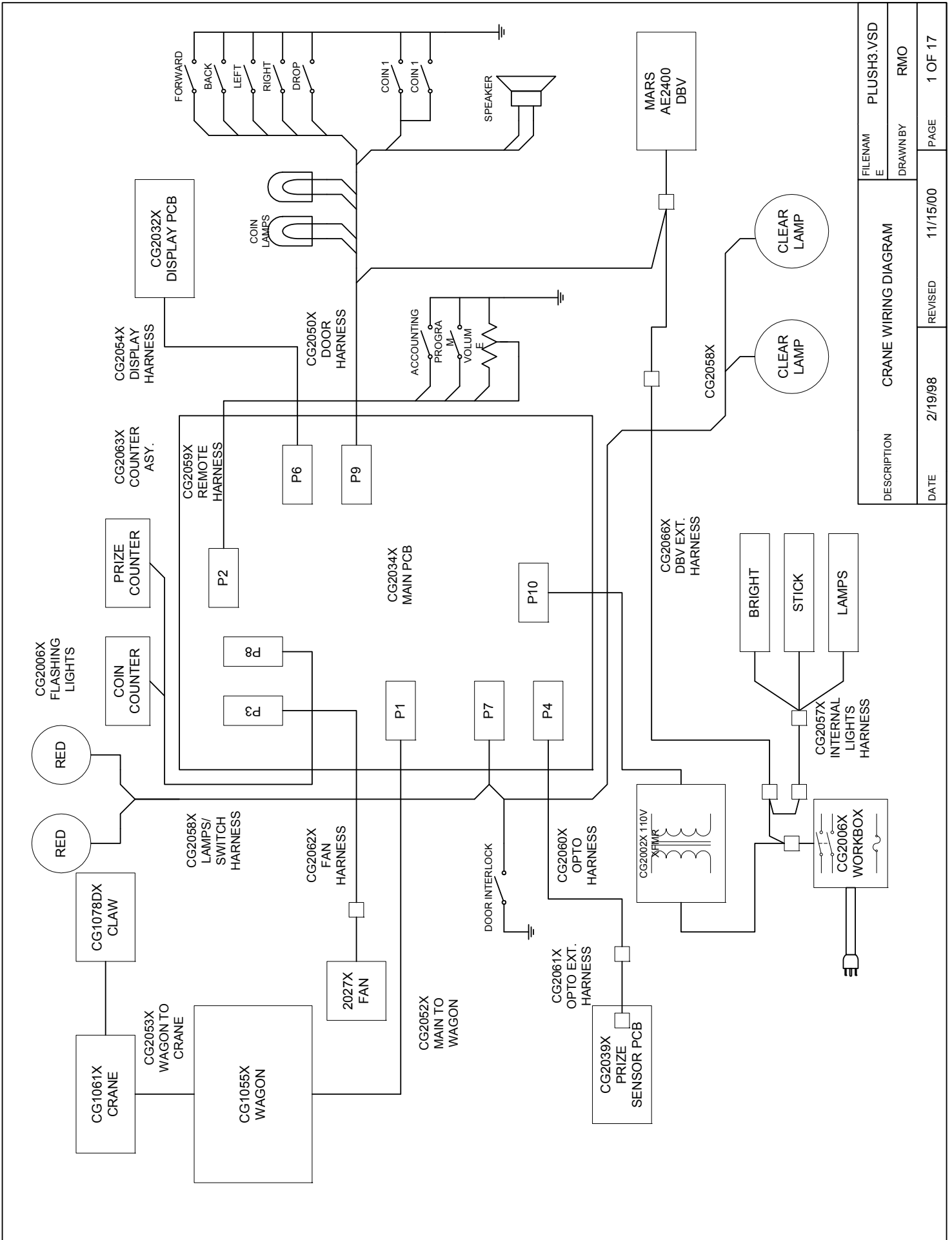

DESCRIPTION	CRANE WIRING DIAGRAM	FILENAM	PLUSH3.VSD
	DATE	2/19/98	DRAWN BY
REVISION	11/15/00	PAGE	1 OF 17

P1

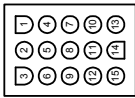

CARRAGE

- 1. MOTOR UP
- 2. MOTOR DOWN
- 3. HOME LEFT / RIGHT SENSOR
- 4. CLAW UP SENSOR
- 5. CLAW DOWN SENSOR
- 6. CLAW CLOSE (CLAW -)
- 7. GROUND
- 8. GROUND
- 9. MOTOR RIGHT
- 10. MOTOR BACK
- 11. HOME FRONT / BACK SENSOR
- 12. MOTOR LEFT
- 13. MOTOR FORWARD
- 14. CLAW POWER (CLAW +)
- 15. 36V

P2



REMOTE

- 1. GROUND
- 2. PROGRAM BUTTON
- 3. ACCOUNTING
- 4. GROUND
- 5. AUDIO TOP
- 6. AUDIO WIPER

P3



TICKETS

- 1. TICKET SENSE
- 2. GROUND
- 3. TICKET RUN
- 4. 12 VOLTS

P4



PRIZE SENSOR

- 1. 12 VOLTS
- 2. PRIZE SENSOR
- 3. GROUND

P6

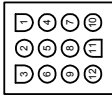

DISPLAY

- 1. SEGMENT A
- 2. SEGMENT B
- 3. SEGMENT C
- 4. SEGMENT D
- 5. SEGMENT E
- 6. SEGMENT F
- 7. 12 VOLTS
- 8. SEGMENT H
- 9. SEGMENT G
- 10. SELECT 1
- 11. SELECT 2
- 12. GROUND

P7

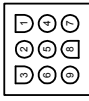

LIGHTS

- 1. 12 VOLTS
- 2. 12 VOLTS
- 3. 12 VOLTS
- 4. DOOR SWITCH
- 5. 12 VOLTS
- 6. HEADLIGHTS
- 7. LEFT BLINKER
- 8. RIGHT BLINKER
- 9. GROUND

P8



COUNTERS

- 1. PRIZE COUNTER
- 2. 5 VOLTS
- 3. MCOIN / CREDIT COUNTER

P9

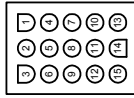

DOOR

- 1. JOYSTICK UP
- 2. JOYSTICK DOWN
- 3. JOYSTICK RIGHT
- 4. JOYSTICK LEFT
- 5. JOYSTICK_BUTTON
- 6. COIN INPUT
- 7. GROUND
- 8. GROUND
- 9. GROUND
- 10. DOLLAR BILL VALIDATOR
- 11. SPEAKER +
- 12. SPEAKER -
- 13. 12 VOLTS
- 14. KEY
- 15. GROUND

P10

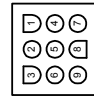

POWER

- 1. KEY
- 2. 16 VAC
- 3. 10 VAC
- 4. 36 VAC
- 5. 10 VAC
- 6. 13 VAC
- 7. 36 VAC
- 8. 16 VAC
- 9. 13 VAC

TITLE

DESCRIPTION

CRANE MAIN BOARD
CONNECTOR PIN OUT

FILENAM
E

PLUSH3.VSD

DRAWN BY

RMO

DATE

REVISED

11/15/00

PAGE

2 OF 17

1 2 3 4

D C B A

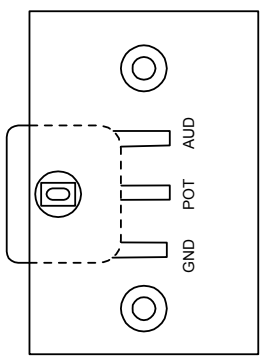
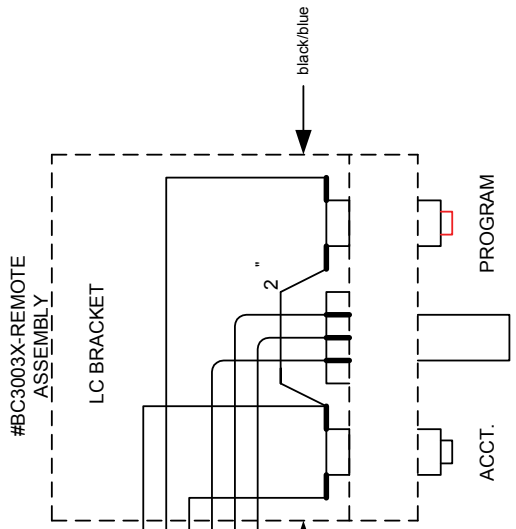

REMOTE P2

1	black	21"
2	black/blue	20"
3	white/gray	19"
4	black	22"
5	red/white	22"
6	red/black	22"

#BC2059X-REMOTE HARNESS

6 PIN PLUG #2173
SOLID PIN #2100S

TITLE		BASIC CRANE#BC3003X	
DESCRIPTION	REMOTE ASSEMBLY	FILENAME	BASIC.VSD
DATE	3/22/99	DRAWN BY	CMZCMZ
		REVISED	7/3/01
		PAGE	1 OF 6

1 2 3 4

D C B A

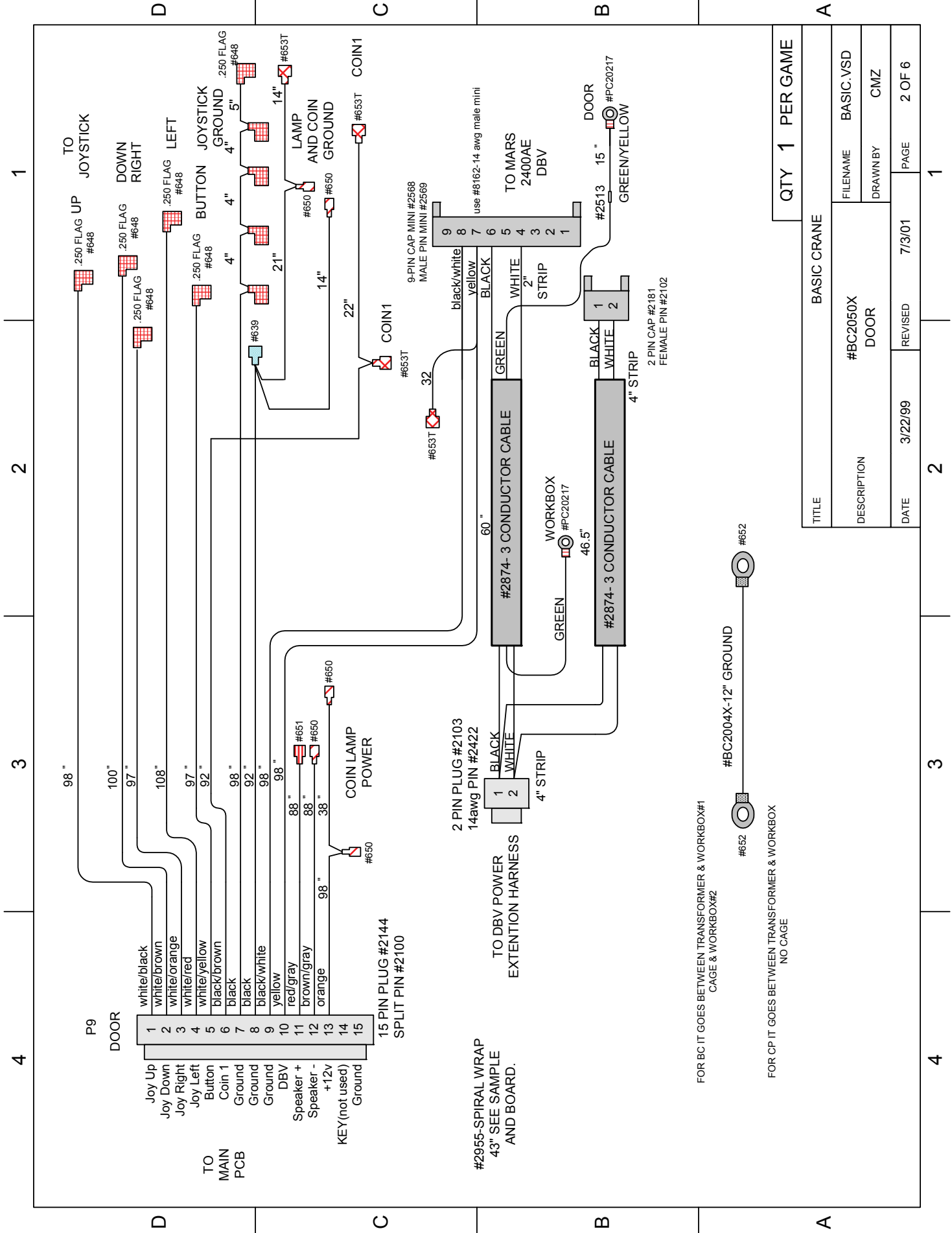

FOR BC IT GOES BETWEEN TRANSFORMER & WORKBOX#1
CAGE & WORKBOX#2

FOR CP IT GOES BETWEEN TRANSFORMER & WORKBOX
NO CAGE

TITLE		BASIC CRANE		QTY 1 PER GAME	
DESCRIPTION		#BC2050X DOOR		FILENAME	BASIC.VSD
DATE		3/22/99		DRAWN BY	CMZ
REVISED		7/3/01		PAGE	2 OF 6

1 2 3 4

D

C

B

A

P6

DISPLAY

1	brown
2	red/black
3	orange/black
4	yellow
5	green
6	blue
7	ORANGE
8	gray
9	white
10	black/white
11	tan
12	BLACK

95"

1
2
3
4
5
6
7
8
9
10
11
12

TO MAIN PCB

TO DISPLAY PCB

12 PIN PLUG #2106
SPLIT PIN #2100

12 PIN PLUG #2106
SPLIT PIN #2100

QTY 1 PER GAME			
TITLE BASIC CRANE			
DESCRIPTION	#BC2054X Display	FILENAME	BASIC.VSD
DATE	3/22/99	DRAWN BY	CMZRMO
		REVISED	7/3/01
		PAGE	3 OF 6

1 2 3 4

D

C

B

A

1 2 3 4

D

C

B

A

P7

- 1
- 2
- 3
- 4
- 5
- 6
- 7
- 8
- 9

yellow/black

40"



#651

black

40"



#651

9 PIN PLUG #2292
SOLID PIN #2100S

QTY 1 PER GAME

TITLE		BASIC CRANE	
DESCRIPTION		FILENAME	BASIC.VSD
DATE		DRAWN BY	CMZRM0
3/22/99	REVISED	7/3/01	PAGE
2	1	5 OF 6	1

1 2 3 4

D

C

B

A

1 2 3 4

D C B A

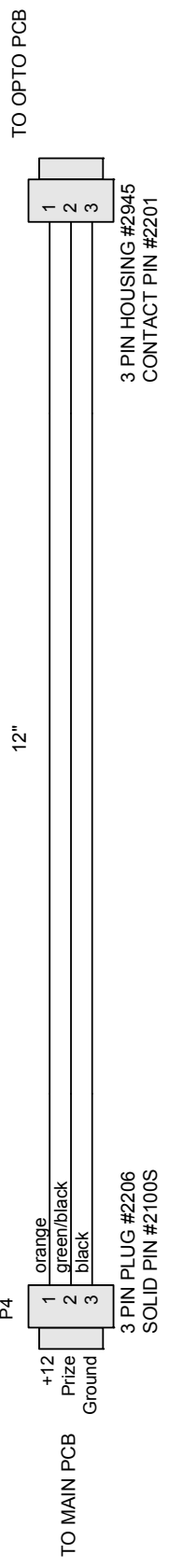

QTY 1 PER GAME	
TITLE BASIC CRANE	
DESCRIPTION #BC2060X Opto	FILENAME BASIC.VSD
DATE 3/22/99	DRAWN BY CMZRMO
REVISED 7/3/01	PAGE 6 OF 6

1 2 3 4

4 3 2 1

MAIN TO WAGON LOWER HARNESS

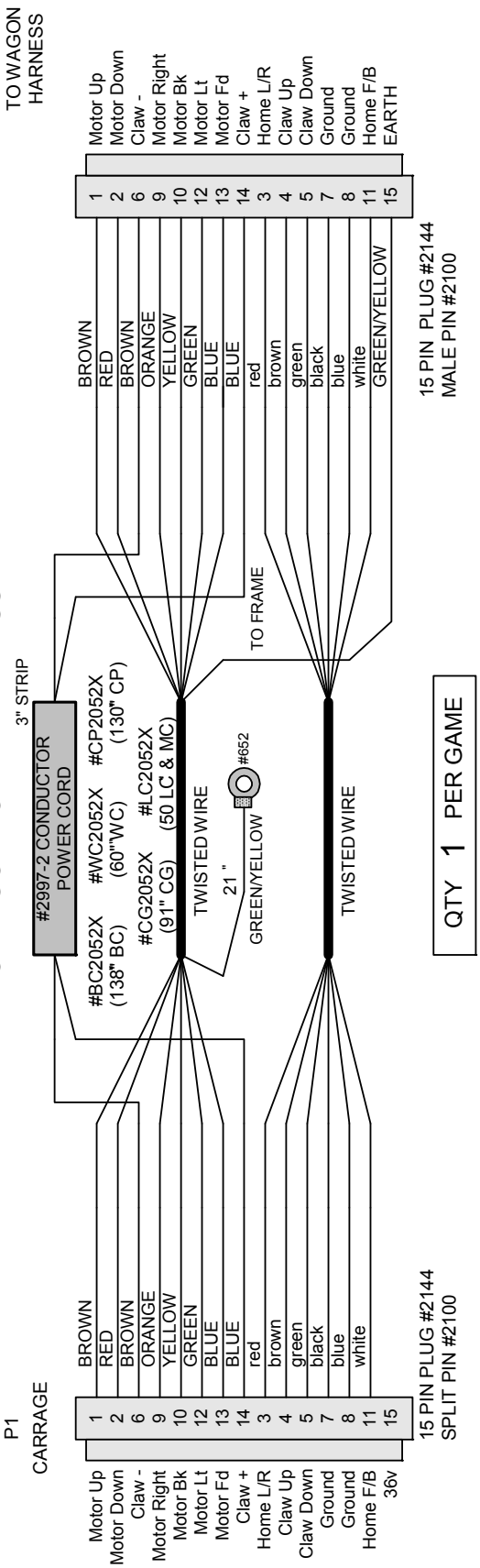

QTY 1 PER GAME

MAIN TO WAGON UPPER HARNESS

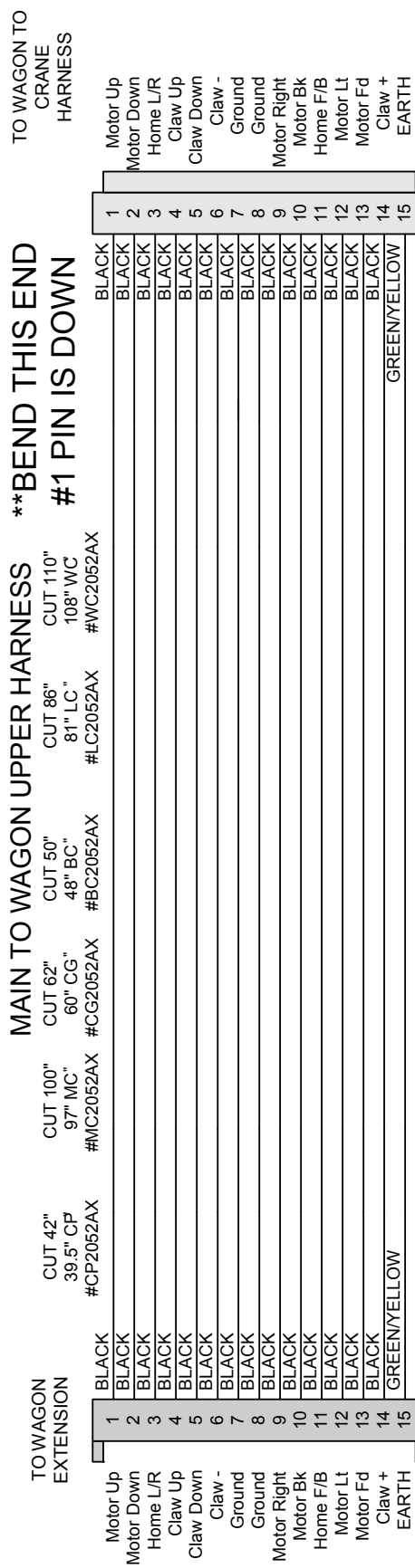

QTY 1 PER GAME

NOTE:
PRIOR TO 9/11/98
THIS CONNECTOR
WAS A 15 PIN MINI
PLUG W/ FEMALE
PINS

NOTE:
PRIOR TO 1/17/99
THIS HARNESS WAS
PART OF THE WAGON
EXTENSION HARNESS

TITLE	Main/Wagon UPPER & LOWER		FILENAM	PLUS3.VSD
DESCRIPTION			DRAWN BY	CHERYLZ1RMO
DATE	2/19/98	REVISED	11/15/00	PAGE 3 OF 17

4 3 2 1

4 3 2 1

FOR 60" SL SINGLE DO THE HIGHLIGHTED AREAS!!!

MOVE OVER ON CRANE ASY

TO MAIN TO WAGON HARNESS

34.5" (CUT 36") CG2053X BC



30" (CUT AT 32") LC2053X

TO CRANE HARNESS

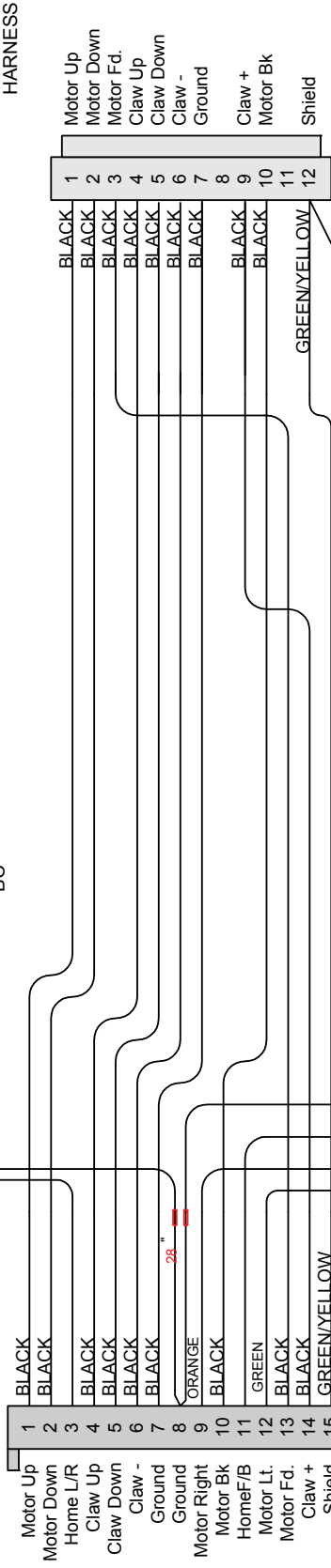

15 PIN CAP #2367 FEMALE PIN #2102 PIN #15 USE #2013-14 AWG

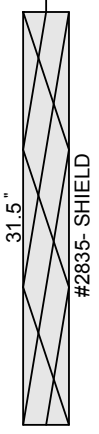

NOTE: PRIOR TO 9/11/98 THIS CONNECTOR WAS A 15 PIN MINI CAP W/ MALE PINS #8162-20-16 AWG MINI

NOTE: SHIELD REQUIRED FOR CE GAMES ONLY

USE A #2422-14 AWG MALE PIN WHEN USING SHIELD IN PIN 12.

NOTE: PRIOR TO 9/11/98 THIS CONNECTOR WAS A 12 PIN MINI PLUG WITH FEMALE PINS #8163-MINI

D C B A

QTY 1 PER GAME

TITLE		#CG2053X	
DESCRIPTION	Wagon /Crane	FILENAM	PLUSH3.VSD
DATE	2/19/98	DRAWN BY	CHERYLZ1RMO
REVISED	11/15/00	PAGE	4 OF 17

4 3 2 1

4 3 2 1

D C B A

TO WAGON TO
CRANE
HARNESS

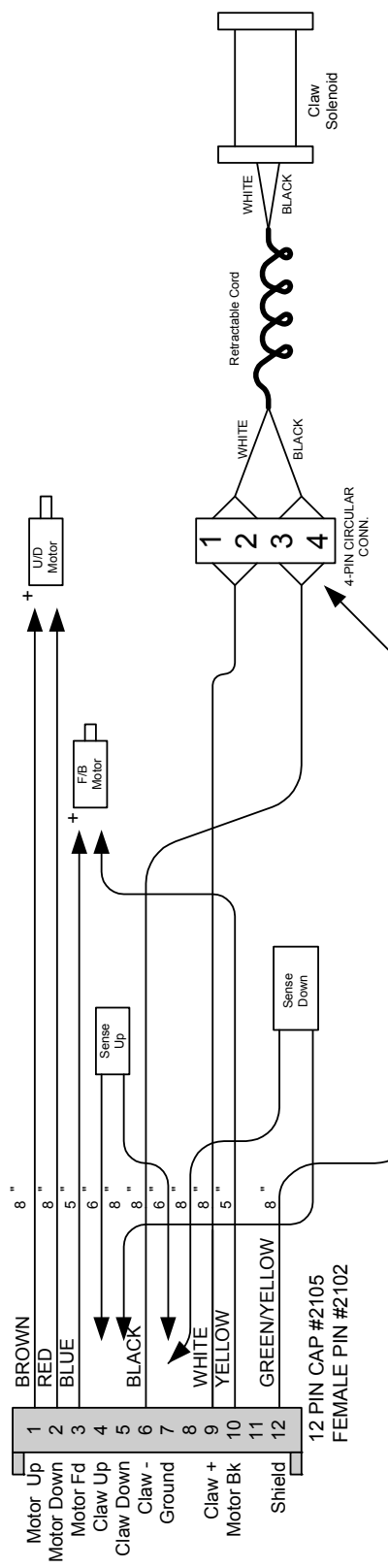

NOTE:
PRIOR TO 9/11/98
THIS CONNECTOR
WAS A 12 PIN MINI
CAP WITH MALE PINS

NOTE:
CONN IS PART OF THE CRANE BOM
SUB ASY SOLDERS THE WIRES FOR
THE MOTORS DIRECT AND ADDS THE
PINS ON THE SENSORS MAKING THOSE
PARTS PART OF THE CRANE BOM!

QTY 1 PER GAME

TITLE		#CG2056X	
DESCRIPTION	Crane	FILENAM	PLUSH3.VSD
DATE	2/19/98	DRAWN BY	CHERYLZ1RMO
		REVISED	11/15/00
		PAGE	5 OF 17

4 3 2 1

D C B A

1 2 3 4

D C B A

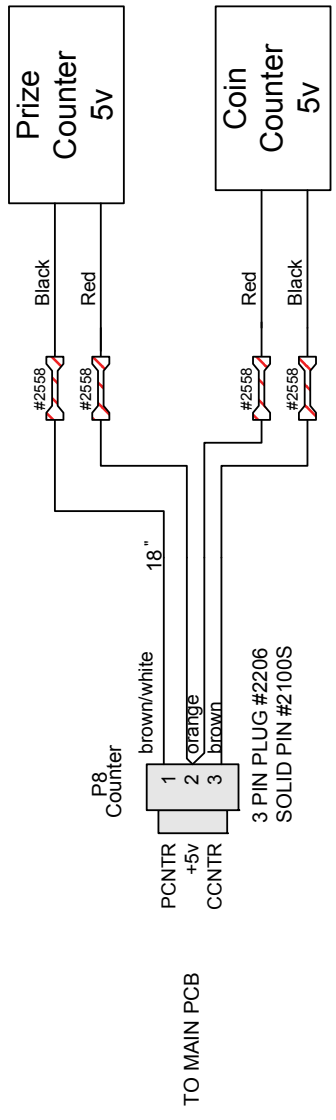

QTY 1 PER GAME

TITLE		#CG2063X	
DESCRIPTION	Counter	FILENAM	PLUSH3.VSD
DATE	2/19/98	DRAWN BY	CHERYLZ1RMO
REVISED	11/15/00	PAGE	12 OF 17

1 2 3 4

1 2 3 4

TRANSFORMER #CG2002
120V PRIMARY MCI# 2-51-9813

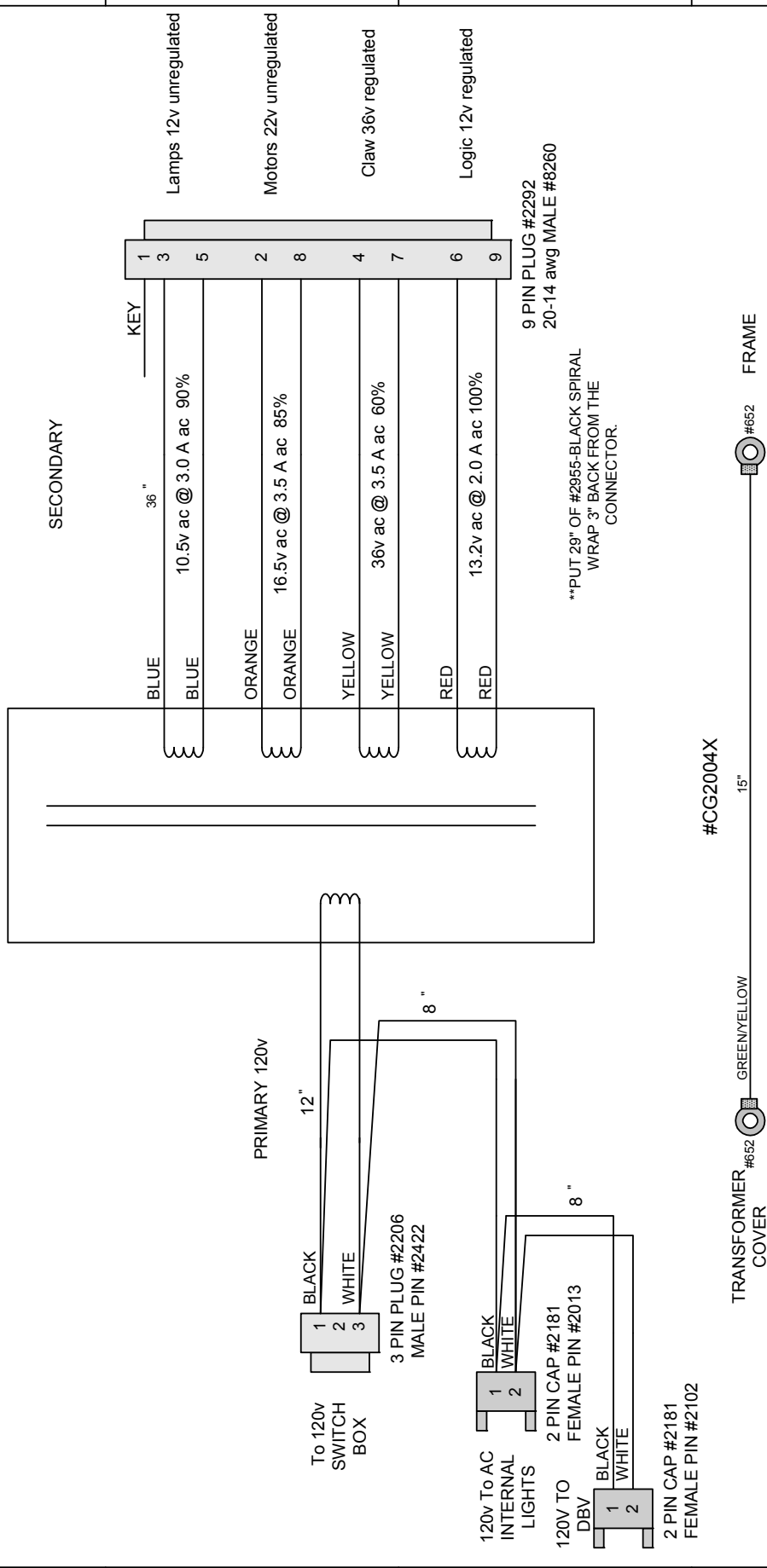

TITLE		#CG2002X/CG2004X	
DESCRIPTION	110v Transformer	FILENAM E	PLUSH3.VSD
DATE	2/19/98	DRAWN BY	CHERYLZ1RMO
	REVISED	11/15/00	PAGE 14 OF 17

1 2 3 4

1 2 3 4

D C B A

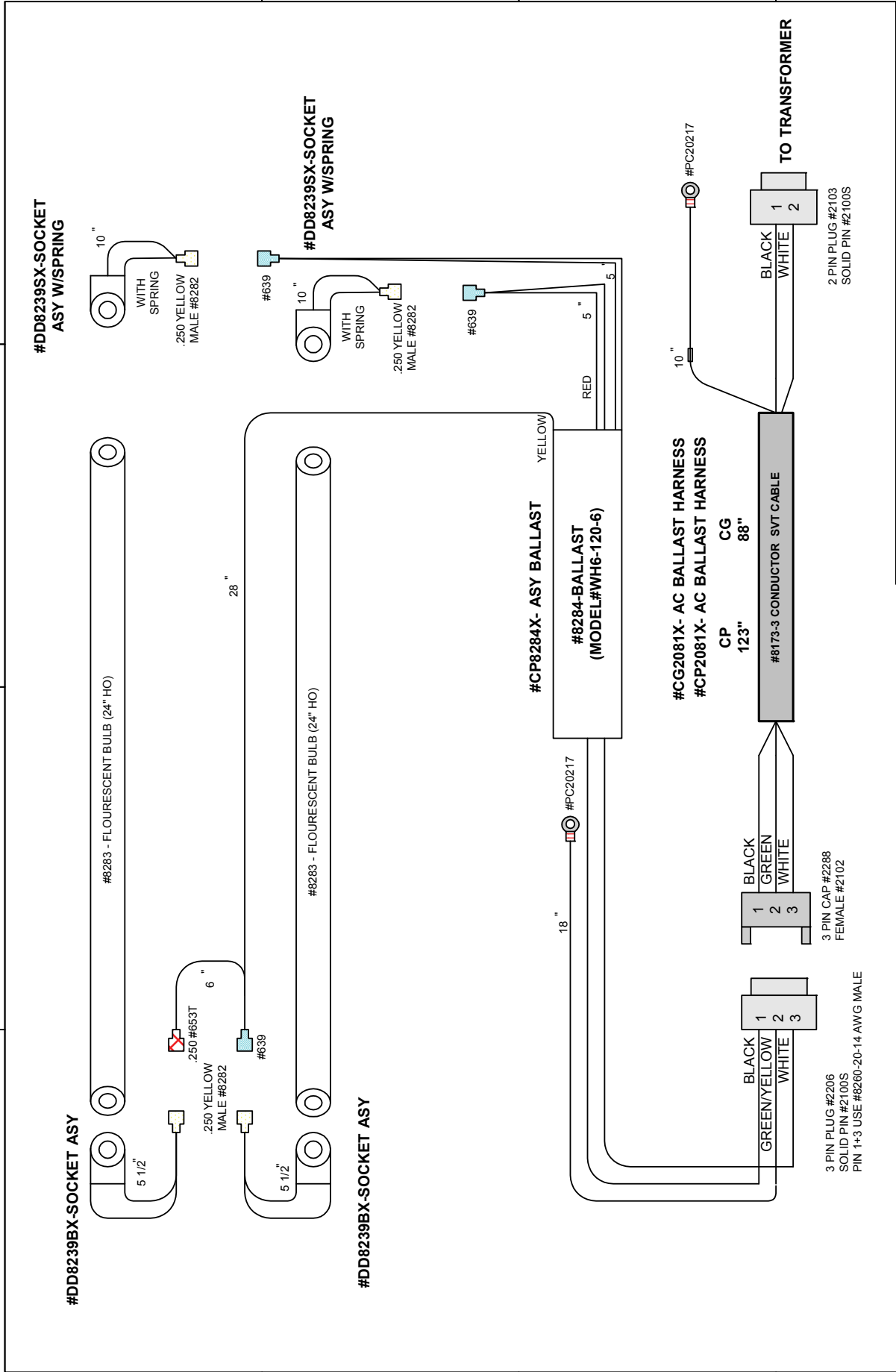

TITLE	Cranpush	
DESCRIPTION	#CP8284X-ASY BALLAST #CP2081X-HARNESS AC BALLAST	FILENAM CRANPUSH2.VSD E DRAWN BY RMO
DATE	9/15/99	REVISED 12/4/00
PAGE	16	OF 16

1 2 3 4

4 3 2 1

D C B A

#CG2062X-FANTICKET EXTENSION HARNESS

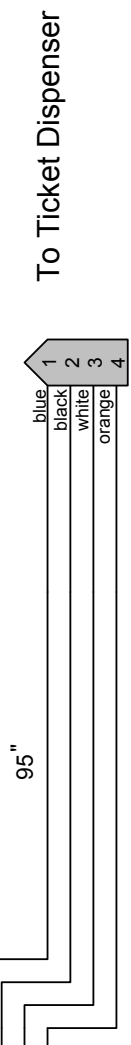
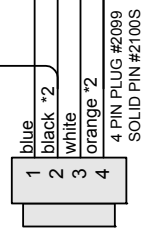
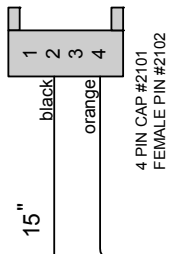
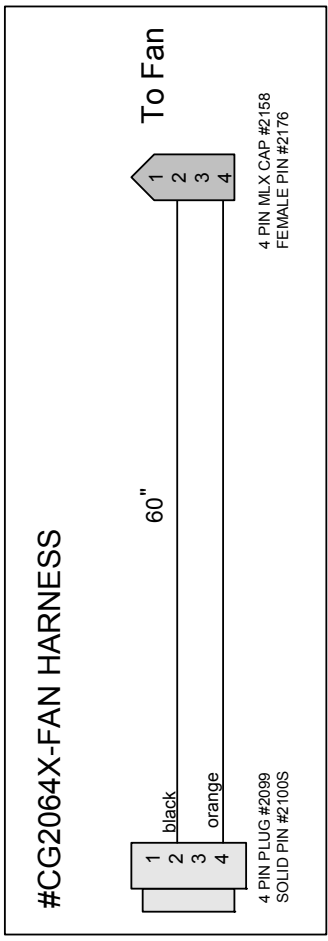

TITLE				FanTicket Extension			
DESCRIPTION		FILENAME		DRAWN BY		PAGE	
		FANTICKET.VSD		MMARTIN		1 OF 1	
DATE	2/16/01	REVISED	2/27/01				

4 3 2 1

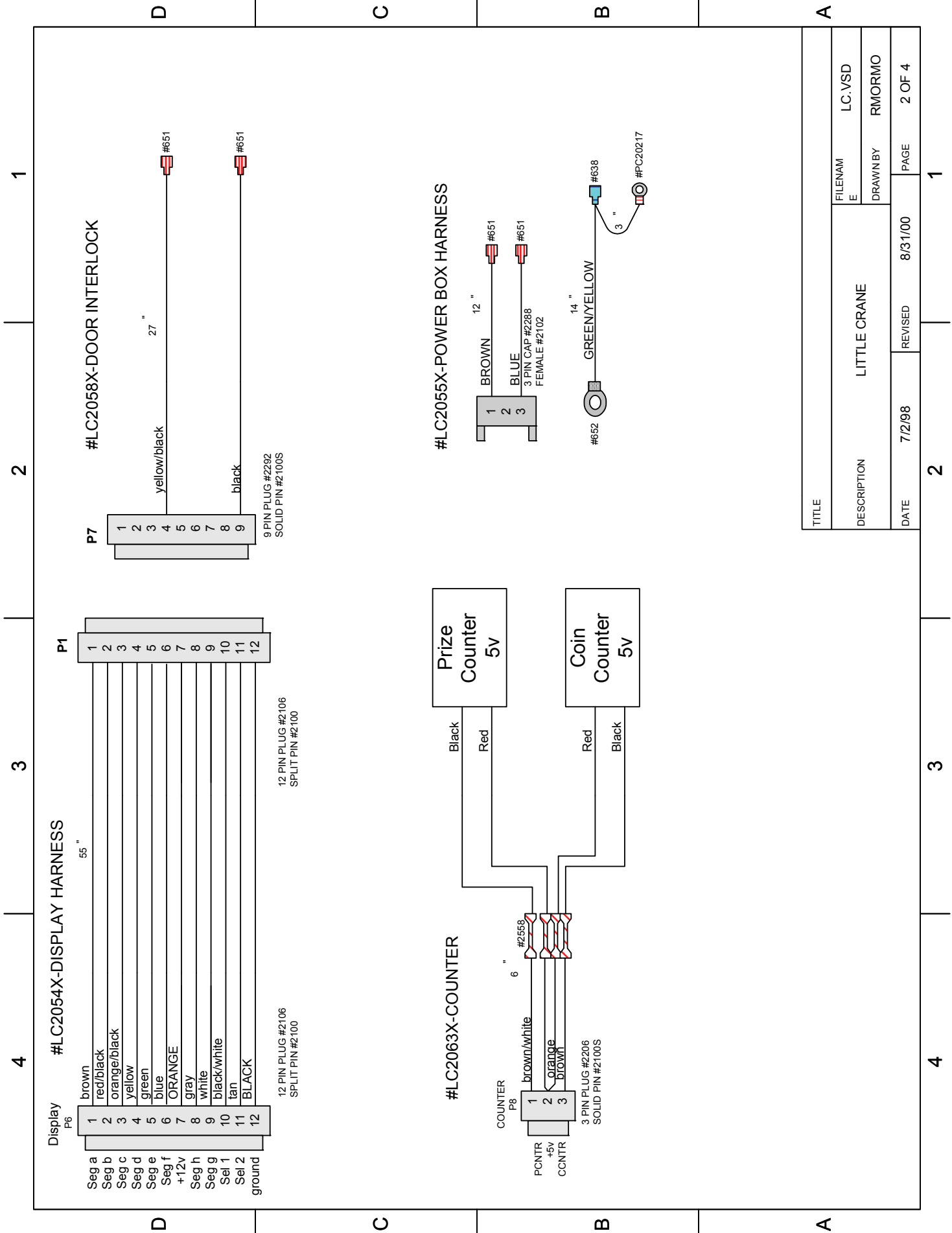

TITLE	LITTLE CRANE		FILENAM E	LC.VSD
DESCRIPTION	LITTLE CRANE		DRAWN BY	RMORMO
DATE	7/2/98	REVISED	8/31/00	PAGE 2 OF 4

4 3 2 1

D

C

B

A

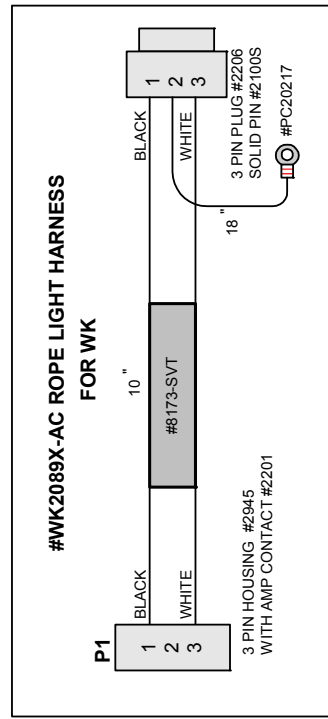
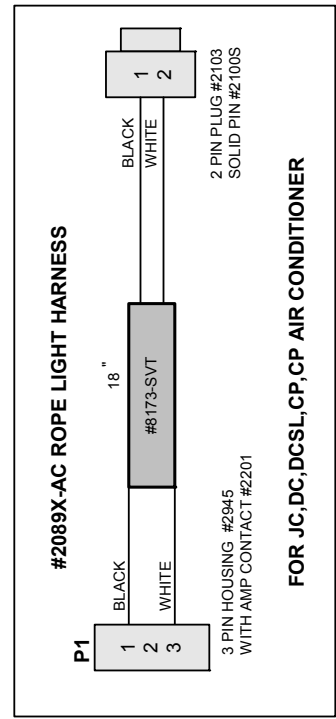
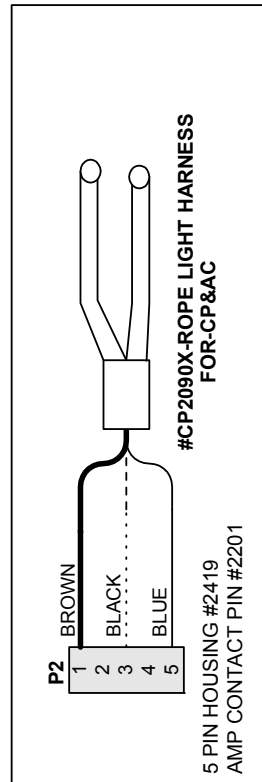
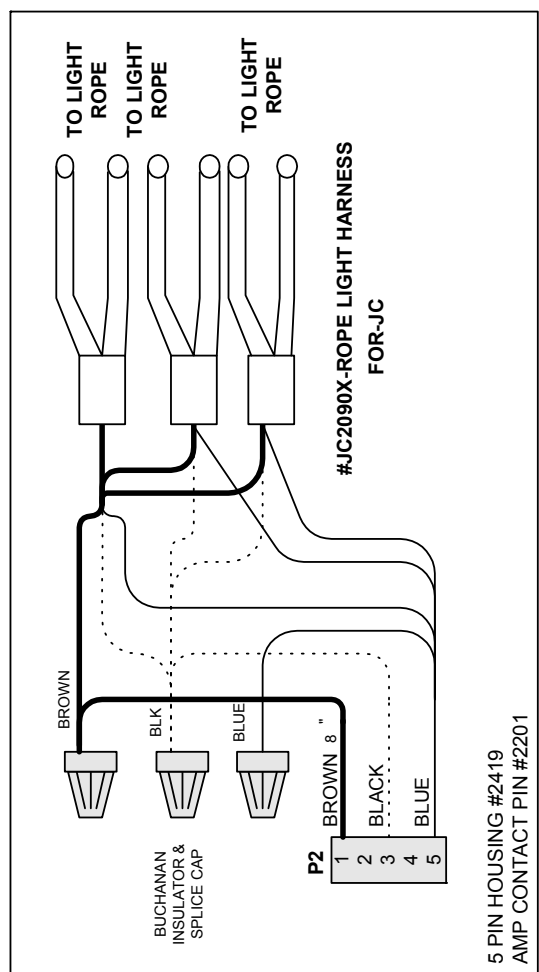
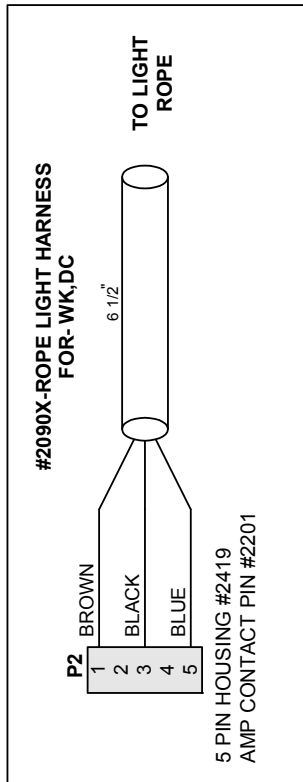
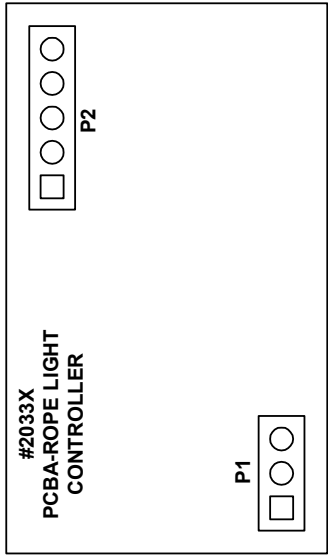

TITLE	LIGHT ROPE CONTROLLER	
DESCRIPTION	FILENAM E	CONTROLLER.VS
DATE	DRAWN BY	PAGE
6/23/00	CHERYLZ1	1 OF 1
REVISED	12/6/00	

4 3 2 1

D

C

B

A

WARRANTY

I.C.E warrants all components in the **JEWELRY CRANE™** game to be free of defects in materials and workmanship for a period of ninety days from the date of purchase.

This warranty does not cover items damaged due to normal wear and tear, subjected to abuse, improperly assembled by the end user, modified, repaired, or operated in a fashion other than that described in the service manual.

If your **JEWELRY CRANE™** game fails to conform to the above-mentioned warranty, I.C.E.'s sole responsibility shall be at its discretion to repair or replace any defective component with a new or remanufactured component of equal to or greater O.E.M. specification.

I.C.E. will assume no liability whatsoever, for costs associated with labor to replace defective parts, or travel time associated therein.

I.C.E.'s obligation will be to ship free of charge, replacement parts by U.P.S. Ground, U.S. mail, or other comparable shipping means. Any express mail or overnight shipping expense is at the cost of the purchaser.

Products will be covered under warranty only when:

- The serial number of the game with the defective parts is given.
- The serial number of the defective part, if applicable, is given.
- Defective parts are returned to I.C.E., shipping pre-paid, in a timely fashion, if requested by I.C.E.
- A copy of the sales receipt is available as proof of purchase upon request of I.C.E.

I.C.E. distributors are independent, privately owned and operated. In their judgment, they may sell parts or accessories other than those manufactured by I.C.E. We cannot be responsible for the quality, suitability, or safety of any non-I.C.E. part, or any modification, including labor, which is performed by such a distributor.



WARRANTY

ICE Inc warrants that all of its products will be free from defects in material and workmanship.

When placing a warranty request, please be prepared to provide the following information:

- Serial Number of Game or Bill of Sale
- Machine Type
- A Detailed Description of the Equipment Fault Symptoms

ICE product, including Cromptons, Sam's Billiards, Uniana and Bell Fruit is warranted as follows:

- 180 days on the Main PCB and Computers
- 90 days on all other components (i.e. DBV's, Ticket Dispensers, etc)
- 30 days on repaired items
- 3 years on all Crane Harnessing
- 9 Months on Printers

ICE Inc shall not be obligated to furnish a warranty request under the following conditions:

- Equipment has been subjected to unwarranted stress through abuse or neglect
- Equipment has been damaged as a result of arbitrary repair/modification attempts
- Equipment that has failed through normal wear and tear

ICE Inc will assume no liability whatsoever for costs associated with labor to replace defective parts or travel time associated therein.

All defective warranty covered components will be replaced with new or factory refurbished components equal to OEM specifications. ICE Inc will cover all UPS ground, or comparable shipping means, freight costs during the warranty period. Expedited shipments are available for an additional charge.

Defective parts are returned to ICE Inc, at the customer's expense, in a timely fashion.

ICE distributors are independent, privately owned and operated. In their judgment, they may sell parts and/or accessories other than those manufactured by ICE Inc. We cannot be responsible for the quality, suitability or safety of any non-ICE part, modification (including labor) that is performed by such a distributor.

I.C.E. Parts/Service Dept.
Innovative Concepts in Entertainment
10123 Main St.
Clarence, NY 14031
Phone #: (716) - 759 - 0360
Fax #: (716) - 759 - 0884